

KK70 Silent

EN

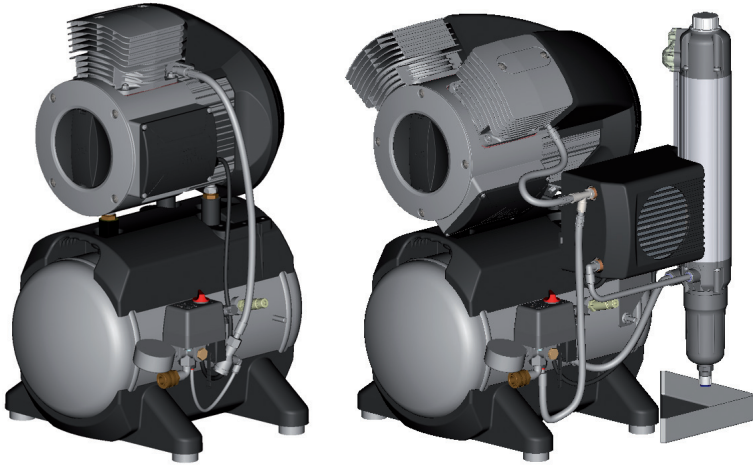

Installation and Operating Instructions

CE

0881100001L02



1502V001

Contents



Important information

1 Documentation	3
1.1 Warnings and symbols	3
1.2 Notes on copyright	3
2 Safety	4
2.1 Intended use	4
2.2 Incorrect use	4
2.3 General safety notes	4
2.4 Qualified personnel	4
2.5 Protection against electrical current	4
2.6 Only use original parts	4
2.7 Transportation and storage	4
2.8 Disposal	5



Product description

3 Overview of compressor units	6
3.1 Delivery Contents	6
3.2 Working parts and spare parts	6
4 Technical data of compressor units	7
4.1 Compressor unit A-100S	7
4.2 Compressor unit A-200S	8
4.3 Performance diagram KK70S	9
4.4 Model identification plate	10
4.5 Mounting	10
4.6 Declaration of conformity for machines in accordance with the 2006/42/EC Directive	12
5 Overview of compressor stations	13
5.1 Delivery Contents	13
5.2 Special accessories	13
5.3 Working parts and spare parts	13
6 Technical data of compressor stations	14
6.1 Compressor station FA-100 MS with membrane drying unit	14
6.2 Compressor station FA-200 MS with membrane drying unit	15
6.3 Model identification plate	16
6.4 Declaration of conformity for machines in accordance with the 2006/42/EC Directive	17

7 Circuit diagram	18
7.1 Units with 230 V	18
7.2 Units with 110 - 127 V	20
8 Function	22
8.1 Device with membrane drying unit	22
8.2 Units without membrane drying unit	22



Mounting

9 Prerequisites	23
9.1 Area of installation	23
10 Transport	24
11 Operation	24
11.1 Remove the transport protection	24
11.2 Set up compressed air connection	24
11.3 Place the collector tray underneath	25
11.4 Electrical connection	25
11.5 Check the motor protection switch	26
11.6 Checking the initial pressure/cut off pressure	26
11.7 Check safety valve settings	27
11.8 Draining the condensate	27
12 Setting possibilities	28
12.1 Pressure switch setting	28



Usage

13 Instructions for use	30
13.1 Switch the unit on/off	30
14 Maintenance	31
14.1 Maintenance plan	31
14.2 Change the air intake filter	32
14.3 Replacing the filter of the membrane-drying unit	32
15 Deactivation	33
15.1 Shut down the unit	33
15.2 Store the unit	34



Trouble-shooting

16 Tips for Operators and Technicians . . . 35

17 Tips for service technicians 36



Addresses

EN



Important information

1 Documentation

These assembly and operating instructions form an integral part of the unit. They correspond to the particular model of the unit and to the technical standards applicable at the time it was brought to market.



In the event that the instructions and information in these assembly and operating instructions are not observed, Dürr Technik undertakes to provide no warranty and accepts no liability of any kind for the safe and reliable operation of the unit.

This translation has been produced to the best of our knowledge. The original German language version of the manual is definitive. Dürr Technik will not be held liable for translation errors.

1.1 Warnings and symbols

Warnings

The warnings in this document are there to point out possible injury to persons or damage to machinery.

The following warning symbols are used:



General warning symbol



Warning - dangerous electrical voltage



Warning - high temperatures



Warning - the unit starts up automatically

The warnings are structured as follows:



SIGNAL WORD

Description of type and source of danger

Possible consequences of ignoring the safety warning here

- Measures to be taken to avoid any possible danger.

The signal word differentiates between different levels of danger:

- **DANGER**
High risk of danger of serious injury or death
- **WARNING**
Possible risk of danger of serious injury or death
- **CAUTION**
Risk of danger of minor injuries
- **NOTICE**
Risk of serious damage

Further symbols

These symbols are used within the documentation and on the unit itself:



Notes, e.g. special instructions concerning economical use of the unit.



Observe the accompanying documentation.



CE-labeling



Date of manufacture



Dispose of the unit properly according to valid state and local legislation.



Switch off the unit (i. e. unplug and disconnect from mains).

1.2 Notes on copyright

All circuits, processes, names, software programs and units specified are protected under industrial property rights.

The reprinting of the assembly and operating instructions, even in extracts, is only permitted with the written permission of Dürr Technik.

2 Safety

Dürr Technik has designed and developed the unit in such a way that danger is to a large extent excluded if the unit is used as intended. However, residual risks may be present. Therefore, please observe the following information.

2.1 Intended use

The unit is designed for compressing atmospheric air. This unit is designed to be operated in dry, ventilated rooms. The unit must not be operated in wet or damp environments. Use of the unit in the proximity of gases or combustible liquids is prohibited. Ensure that mobile units are stationary before operation.

2.2 Incorrect use

Any use of this unit above and beyond that specifically described in these instructions will be deemed to be as not according to the intended use. The manufacturer cannot be held liable for any damage resulting from incorrect usage. The user bears all risks.



WARNING

Serious injury and material damage due to improper usage

- Conveying explosive mixtures in any way other than that specified is not permitted.

2.3 General safety notes

- Before using the unit observe any and all guidelines, laws, regulations and other restrictions which may apply to the unit.
- Before each use check the function and condition of the unit.
- Do not convert or change the unit in any way.
- Observe the Installation and Operating Instructions precisely.
- Keep the Installation and Operating Instructions in an accessible place so that the operator has instant access to them.

2.4 Qualified personnel

Instructions for use

Persons who operate the unit must, on the basis of their training and knowledge, ensure safe and correct handling of the unit.

- Ensure personnel are trained in the correct usage of the unit.

Installation and repair

- Assembly and installation work, readjustments, modifications, upgrades and repairs must be carried out by Dürr Technik or personnel authorised and trained by Dürr Technik, who are familiar with the technology used in the unit and are aware of the risks involved when working on or operating the unit.

2.5 Protection against electrical current

- Observe all electrical safety regulations when working on the device.
- Replace any damaged lines and plug and socket outlets immediately.

2.6 Only use original parts

- Only use accessories and special accessories that are specified or approved by Dürr Technik.
- Only use original wear parts and spare parts.



Dürr Technik accepts no liability for damage resulting from the use of non-approved accessories, special accessories or any wear parts or spare parts other than original parts.

2.7 Transportation and storage

The unit is shipped in a cardboard box filled with packaging padding. This packaging ensures that the unit is optimally protected in transit. As far as possible, always use the original packaging for transporting or storing the unit.

- Keep packaging away from children.



WARNING

Explosion of the pressure receiver and pressure hoses

- Ensure that the air has been evacuated from the pressure receiver and pressure hoses when they are stored and transported.
- Protect the unit against moisture during transit.
- Always transport the unit in an upright position.
- Only transport the unit using the transport handles provided.
- Do not transport the unit by the air air intake filter.



The unit may be stored in its original packaging:

- in warm, dry and dust-free rooms;
- protected from contaminants.



If possible, retain the packaging material.

2.8 Disposal

Unit



Dispose of the unit properly according to valid state and local legislation.

Packaging



Dispose of packaging material in an environmentally responsible manner.

- Note current disposal routes.
- Keep packaging away from children.



Product description

3 Overview of compressor units

3.1 Delivery Contents

The delivery includes the following articles:

- Compressor unit
- Installation and operating instructions

3.2 Working parts and spare parts

Air air intake filter and vibration damper must be replaced regularly (see "14 Maintenance")

	Type	A-100S	A-200S
	Article no.	5182-100-50DT	5282-100-50DT
Air air intake filter	-	5180-982-00	5180-982-00

	Type	A-100S	A-200S
	Article no.	5182-100-50DT	5282-100-50DT
Crankcase cover		5180-100-10	5180-100-10
Spare parts kit: cup seal / cylinder	-	on request	on request
Vibration damper set		For stationary installation: 0881 0100 For mobile installation (e.g. commercial vehicles) 0881 0200	For stationary installation: 0881 0100 For mobile installation (e.g. commercial vehicles) 0881 0200
	-		

4 Technical data of compressor units

4.1 Compressor unit A-100S

Electrical data			
Type		A-100S	
Article no.		5182-100-50DT	
Mains frequency	Hz	50	60
Nominal voltage	V	230	230
Rated output	kW	0.9	1.09
Rated current	A	3.7	4.4
Rotational speed	min ⁻¹	1340	1560
Duty cycle		100%	100%
Type of protection	IP	44	44

General technical data			
Delivery volume 0 bar	l/min	100	118
Rated pressure	bar	8	8
Safety valve, max. permissible operating pressure	bar	10	10
Sound pressure level	dB(A)	64	66
Weight	kg	19	19
Dimensions (l x w x h)		350 x 330 x 260	350 x 330 x 260
	mm		
Remarks			

Ambient conditions for operation			
Temperature	°C	+10 to +40	+10 to +40

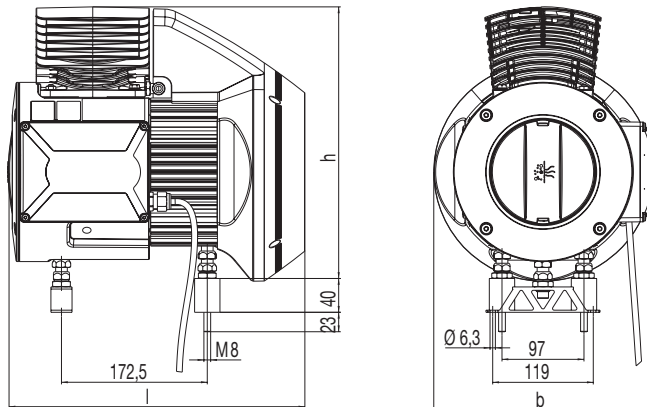

Figure 1: KK70S; type: A-100S

4.2 Compressor unit A-200S

Electrical data			
Type		A-200S	
Article no.		5282-100-50DT	
Mains frequency	Hz	50	60
Nominal voltage	V	230	230
Rated output	kW	1.45	1.70
Rated current	A	7.1	6.5
Rotational speed	min ⁻¹	1392	1662
Duty cycle		100%	100%
Type of protection	IP	44	44

General technical data			
Delivery volume at 0 bar	l/min	200	236
Rated pressure	bar	8	8
Safety valve, max. permissible operating pressure	bar	10	10
Sound pressure level	dB(A)	68	70
Weight	kg	27.5	27.5
Dimensions (l x w x h)	mm	400 x 310 x 360	400 x 310 x 360
Remarks			

Ambient conditions for operation			
Temperature	°C	+10 to +40	+10 to +40

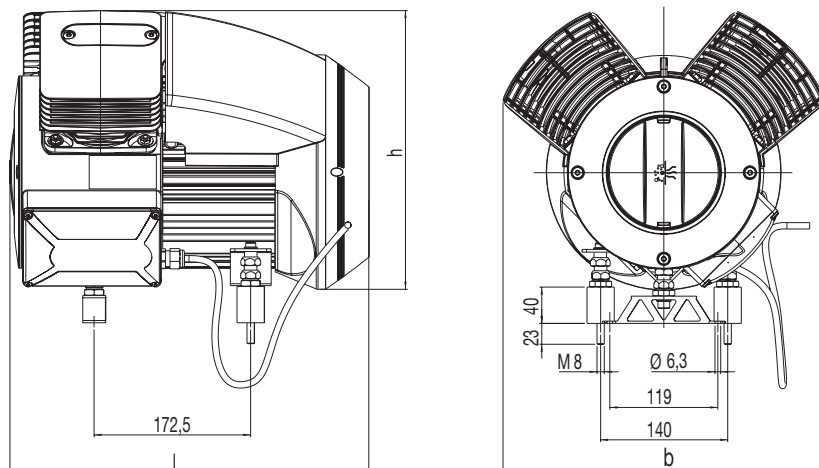

Figure 2: KK70S; type: A-200S

4.3 Performance diagram KK70S

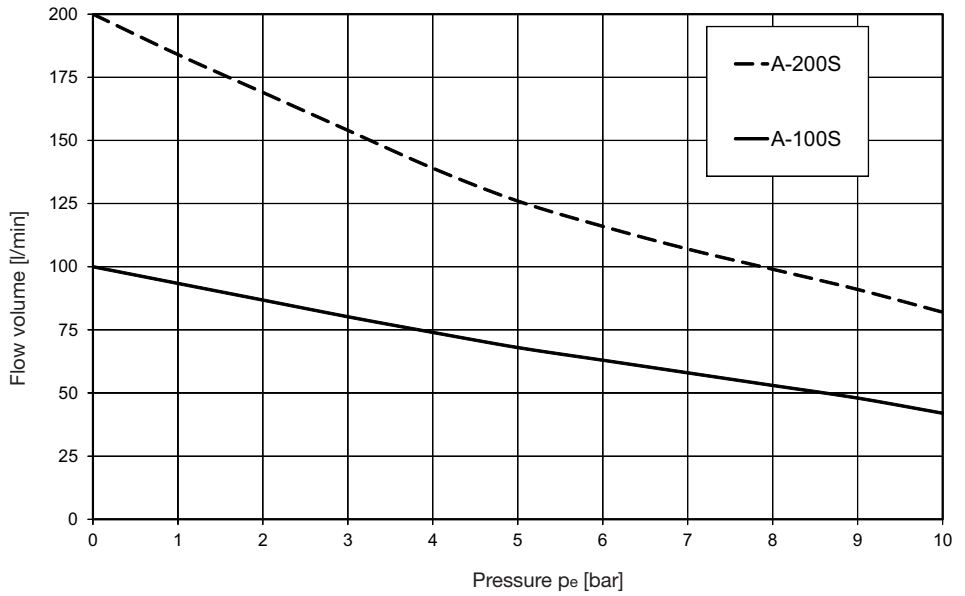
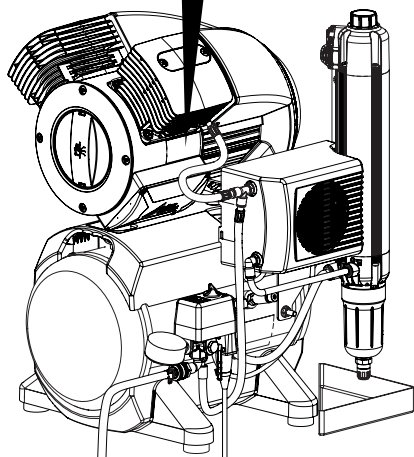

Figure 3: Delivery volume at 50 Hz (60 Hz approx. +18 %)

4.4 Model identification plate

The type plate of the unit is located on the crankcase.



REF Order number

SN Serial number

4.5 Mounting

Installing the compressor generator

- Fix the metal shock absorbers to the fixtures on the compressor generator.

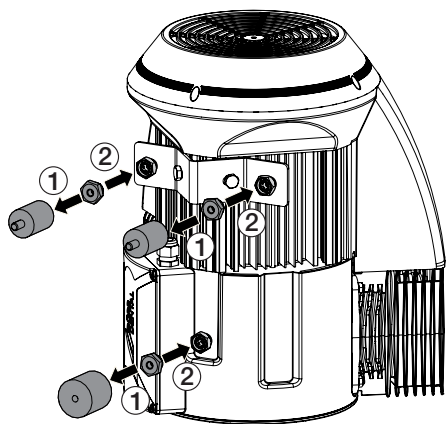

Establish electrical connection

- Before initial start-up check the supply voltage against the voltage values as found on the model identification plate (see also "4 Technical data of compressor units")
- Connect the unit according to the layout shown on the circuit diagram.

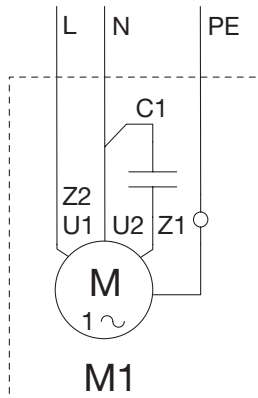

L Live connection

N Neutral connection

PE Protective wire

M1 Compressor motor

Set up compressed air connection



NOTICE

Pressure hoses can become damaged when placed near or against hot compressed air connections.

- Use connection parts and hoses which are capable of withstanding temperatures up to 140 °C.
- Connect pressure hoses using metallic connection pieces. The connection pieces used must adhere to the following specifications:

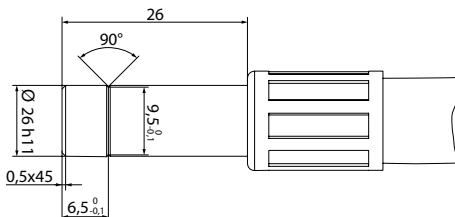

- Connect the pressure hose to the compressor generator.

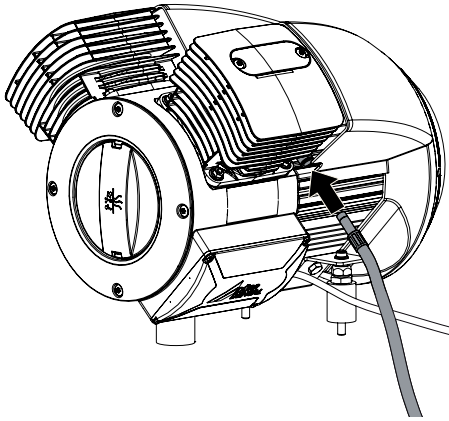



4.6 Declaration of conformity for machines in accordance with the 2006/42/EC Directive

The manufacturer hereby declares that the machine complies with the requirements of the directive cited above and the requirements of the following additional directives:

- Electromagnetic Compatibility (EMC) Directive 2004/108/EC
- RoHS directive 2011/65/EU

Name of manufacturer:	Dürr Technik GmbH & Co. KG
Address of the manufacturer:	Pleidelsheimer Straße 30 74321 Bietigheim-Bissingen, Germany

Reference number:	KK/KV products
Article description:	Compressor or vacuum pump
starting with serial number:	E 000100

We hereby declare that the machine must not be commissioned until it has been established that the machine into which this machine is to be installed complies with the provisions as set out in Machinery Directive 2006/42/EC.

The following harmonised standards and other standards have been applied:

DIN EN 1012-1:2011-02
 DIN EN 1012-1:2011-02
 DIN EN 60034-1: 2011-02
 DIN EN 60034-5: 2007-09
 DIN EN 60335-1:2012-10
 DIN EN 61000-6-2:2006-03
 DIN EN 61000-6-3:2011-09
 DIN EN 60204-1:2007-06
 DIN EN ISO 12100-1:2004-04
 DIN EN ISO 12100-2:2004-04
 DIN EN 50106:2009-05

Bietigheim-Bissingen, 30 Sept. 2014

Andreas Ripsam
 General manager at Dürr Technik

Proof of signature in the
 original document in the Dürr Technik archive

5 Overview of compressor stations

5.1 Delivery Contents

The delivery includes the following articles:

- Compressor (with/without membrane drying system)
- Braided hose
- Hose nozzle
- Hose clip
- Vibration damper
- Cable tie
- Power cable
- Installation and operating instructions
- Device manual

For compressors with membrane drying unit:

- Water catch tray

5.2 Special accessories

The following articles can be used with the device as options:

Pressure reducer	6040-992-00
Sterile filter	1640-981-00

5.3 Working parts and spare parts

The following working parts are subject to wear and tear and should be changed at regular intervals (see also "14 Maintenance")

Air intake filter	5180-982-00
Fine filter	1610-121-00
Sterile filter	1640-981-00
Sinter filter	1650-101-00



Information concerning spare parts can be found in our spare parts catalogue under:

www.duerr.de/etk.

6 Technical data of compressor stations

6.1 Compressor station FA-100 MS with membrane drying unit

Electrical data		
Type		FA-100MS
Article no.		5182-01DT
Mains frequency	Hz	50 - 60
Voltage	V	230
Rated current at 8 bar (0.8 MPa)	A	3.7 - 4.4
Rated output	kW	0.9 - 1.09
Rotational speed	min ⁻¹	1340 - 1560
Mains fuse	A	10
Type of protection		IP X4B

General technical data		
Pressure receiver volume	l	20
Delivery volume at 5 bar (0.5 MPa)	l/min	60 - 70**
Charge time 0 - 7.5 bar (0 - 0.75 MPa)	s	133
Duty cycle	%	100
Cut-in/cut-out pressure	bar (MPa)	6 - 7.8 (0.6 - 0.78)
Safety valve, max. permissible operating pressure	bar (MPa)	10 (1)
Water content (Pressure dew point ≤ +5 °C at 7 bar / 0.7 MPa)	ppm	≤ 870
Sound pressure level	dB(A)	approx. 64*
Dimensions (l x w x h)	cm	49 x 66 x 43
Weight	kg	37

* according to EN ISO 1680 (airborne noise emission); measured in noise-insulated room.

** Value depending on mains frequency

Filter grade		
Air air intake filter of compressor	µm	3
Fine filter for membrane drying unit	µm	3
Sterile filter for membrane drying unit	µm	0.01
Sinter filter for membrane drying unit	µm	35

Ambient conditions during operation and transportation		
Temperature	°C	-10 to +55
Relative humidity	%	max. 95

Ambient conditions for operation		
Temperature	°C	+10 to +40
Optimal temperature	°C	+10 to +25
Relative humidity	%	max. 95

6.2 Compressor station FA-200 MS with membrane drying unit

Electrical data		
Type	FA-200MS	
Article no.	5282-01DT	
Mains frequency	Hz	50 - 60
Voltage	V	230
Rated current at 8 bar (0.8 MPa)	A	7.3 - 6.7**
Rated output	kW	1.45 - 1.70**
Rotational speed	min ⁻¹	1392 - 1662**
Mains fuse	A	16
Type of protection	IP X4B	

General technical data		
Pressure receiver volume	l	20
Delivery volume at 5 bar (0.5 MPa)	l/min	110 - 126**
Charge time 0 - 7.5 bar (0 - 0.75 MPa)	s	73
Duty cycle	%	100
Cut-in/cut-out pressure	bar (MPa)	6 - 7.8 (0.6 - 0.78)
Safety valve, max. permissible operating pressure	bar (MPa)	10 (1)
Water content (Pressure dew point $\leq +5$ °C at 7 bar / 0.7 MPa)	ppm	≤ 870
Sound pressure level	dB(A)	approx. 68*
Dimensions (l x w x h)	cm	49 x 64 x 43
Weight	kg	43

* according to EN ISO 1680 (airborne noise emission); measured in noise-insulated room.

** Value depending on mains frequency

Filter grade		
Air air intake filter of compressor	μm	3
Fine filter for membrane drying unit	μm	3
Sterile filter for membrane drying unit	μm	0.01
Sinter filter for membrane drying unit	μm	35

Ambient conditions during operation and transportation		
Temperature	°C	-10 to +55
Relative humidity	%	max. 95

Ambient conditions for operation		
Temperature	°C	+10 to +40
Optimal temperature	°C	+10 to +25
Relative humidity	%	max. 95

6.3 Model identification plate

The type plate of the overall unit is located on the pressure receiver.

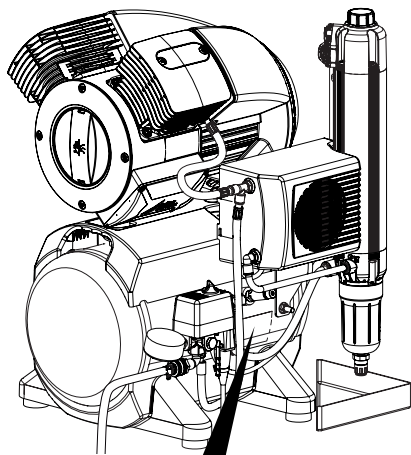

REF Order number

SN Serial number

6.4 Declaration of conformity for machines in accordance with the 2006/42/EC Directive

The manufacturer hereby declares that the machine complies with the requirements of the directive cited above and the requirements of the following additional directives:

- Electromagnetic Compatibility (EMC) Directive 2004/108/EC
- Simple pressure vessel directive 2009/105/EC in its current version
- RoHS directive 2011/65/EU

Name of manufacturer:	Dürr Technik GmbH & Co. KG
Address of the manufacturer:	Pleidelsheimer Straße 30 74321 Bietigheim-Bissingen, Germany

Reference number:	
Article description:	Compressor stations and drying stations Validity: All units that are ready to connect and have a compressor, pressure receiver, and possibly membrane dryer and cooler and control elements, such as a pressure switch, condensate drain, etc. Can normally be identified from the following code (first figure) under the ref. no. on the type plate of the complete unit: UA-025K, WA-038..., TA-100, HB-200..., XB-304..., ZK..., AATA-100..., BBTAG-132..., CCHA-234..., DDHB-304..., SAS...
From serial number:	A 000100

We hereby declare that the machine must not be commissioned until it has been established that the machine into which this machine is to be installed complies with the provisions as set out in Machinery Directive 2006/42/EC.

The following harmonised standards and other standards have been applied:

DIN EN 1012-1:2011-02
 DIN EN 60034-1: 2011-02
 DIN EN 60034-5: 2007-09
 DIN EN 60034-7: 2001-12
 DIN EN 60034-8: 2008-04
 DIN EN 60335-1:2012-10
 DIN EN 61000-6-2:2006-03
 DIN EN 61000-6-3:2011-09
 DIN EN 60204-1:2007-06
 DIN EN ISO 12100:2011-09
 DIN EN ISO 12100-2:2004-04

Bietigheim-Bissingen, 12.01.2012

Andreas Ripsam
 General manager at Dürr Technik

Proof of signature in the
 original document in the Dürr Technik archive

7 Circuit diagram

7.1 Units with 230 V

Units without membrane drying unit

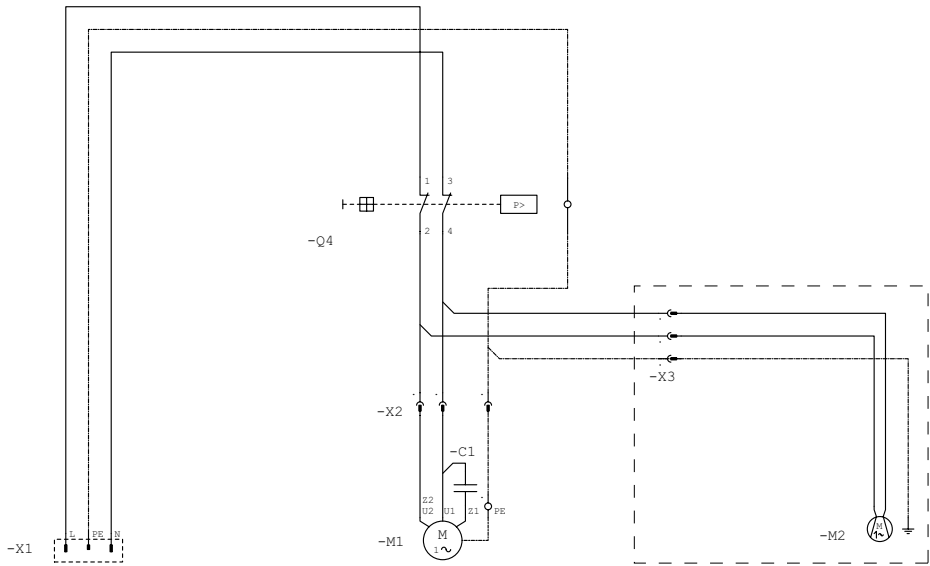

- C1 Capacitor
- M1 Compressor motor
- M2 Fan motor noise reducing hood (optional)
- Q4 Pressure switch
- X1 Power supply 1/N/PE AC 230 V
- X2 Compressor motor connection
- X3 Fan motor noise reducing hood connector (optional)



Device with membrane drying unit

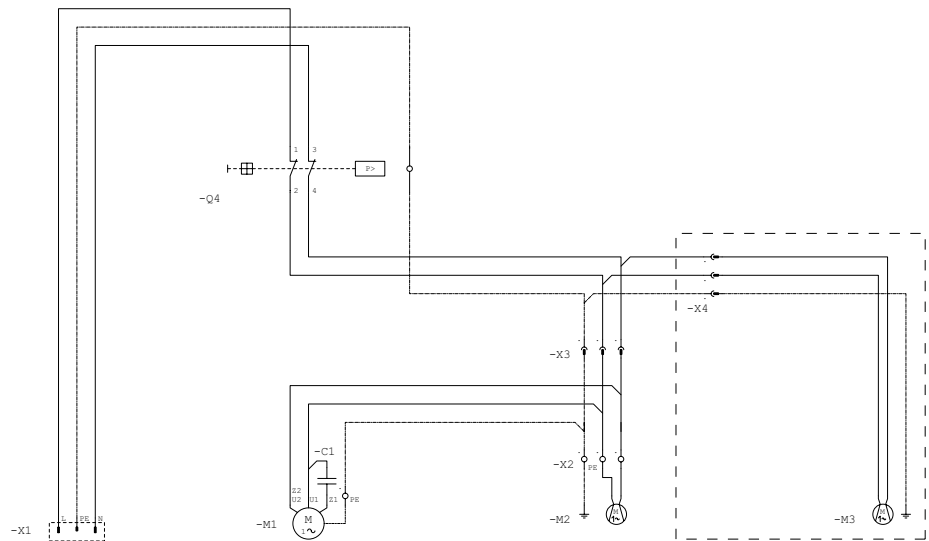

- C1 Capacitor
- M1 Compressor motor
- M2 Fan motor cooling membrane drying unit
- M3 Fan motor noise reducing hood (optional)
- Q4 Pressure switch
- X1 Power supply 1/N/PE AC 230 V
- X2 Fan motor cooling membrane drying unit connection
- X3 Connector of compressor motor and cooler membrane drying unit
- X4 Fan motor noise reducing hood connector (optional)

7.2 Units with 110 - 127 V

Units without membrane drying unit

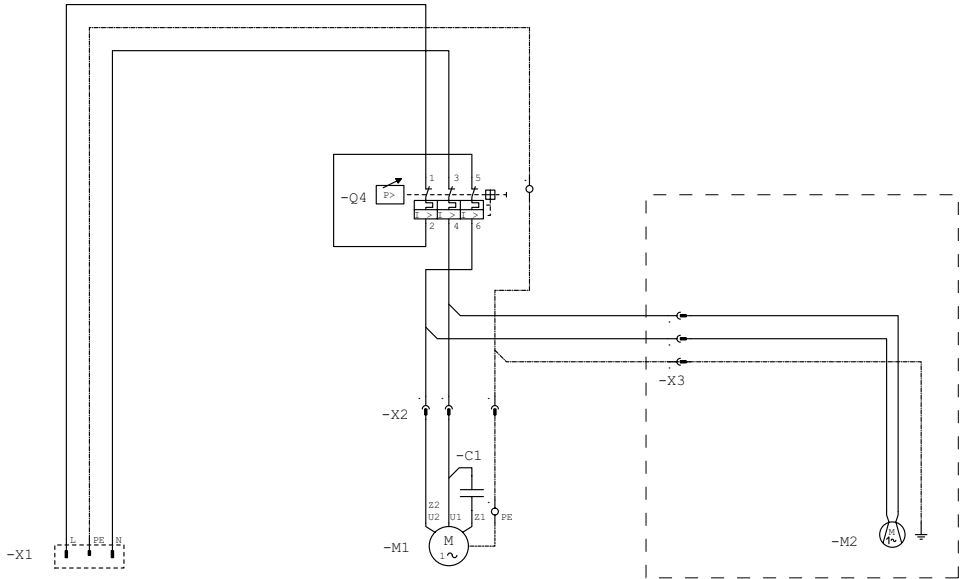

- C1 Capacitor
- M1 Compressor motor
- M2 Fan motor noise reducing hood (optional)
- Q4 Pressure switch
- X1 Power supply 1/N/PE AC 110 - 127 V/230 V
- X2 Compressor motor connection
- X3 Fan motor noise reducing hood connector (optional)



Device with membrane drying unit

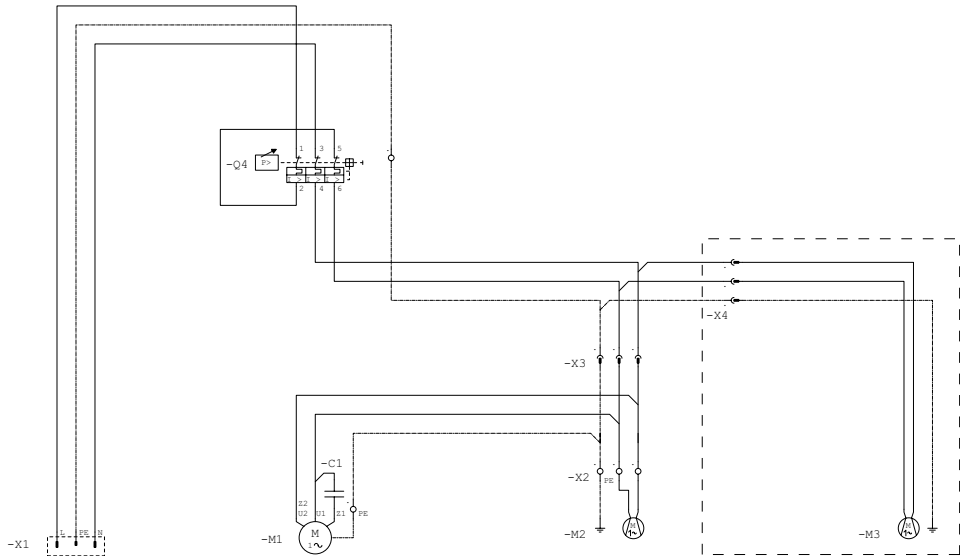

- C1 Capacitor
- M1 Compressor motor
- M2 Fan motor cooling membrane drying unit
- M3 Fan motor noise reducing hood (optional)
- Q4 Pressure switch
- X1 Power supply 1/N/PE AC 110 - 127 V/230 V
- X2 Fan motor cooling membrane drying unit connection
- X3 Compressor motor and cooler membrane drying unit connector
- X4 Fan motor noise reducing hood connector (optional)



8 Function

8.1 Device with membrane drying unit

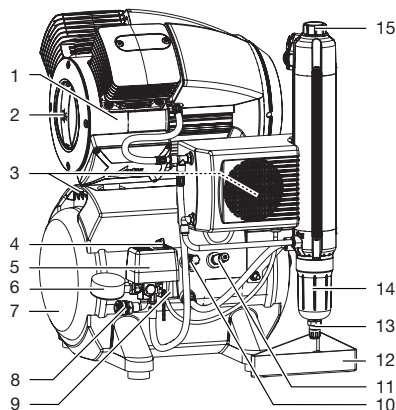

- 1 Compressor
- 2 Air intake filter
- 3 Carrying handle
- 4 ON/OFF switch
- 5 Pressure switch
- 6 Manometer/pressure display
- 7 Pressure tank
- 8 Compressed air connection (quick release coupling)
- 9 Power supply
- 10 Condensate drain valve
- 11 Safety valve settings
- 12 Collector tray
- 13 Automatic/manual condensate outlet valve, membrane drying unit
- 14 Sinter filter, membrane drying unit
- 15 Fine or sterile filter, membrane drying unit

The compressor draws in atmospheric air and compresses this air completely oil free. It then transports the oil-free compressed air to the membrane drying unit. The cooling element and the membrane dryer extract any moisture from the compressed air. The oil-free, hygienic and dry air is stored in the pressure tank and can be made available to the consumer.

8.2 Units without membrane drying unit

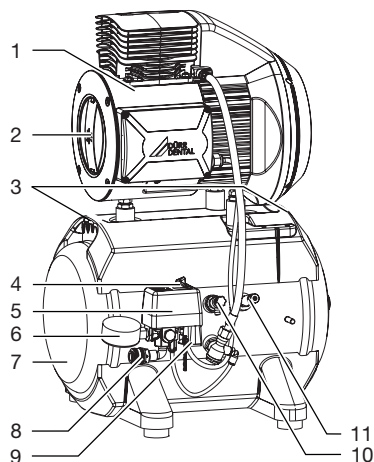

- 1 Compressor
- 2 Air intake filter
- 3 Carrying handle
- 4 ON/OFF switch
- 5 Pressure switch
- 6 Manometer/Pressure display
- 7 Pressure tank
- 8 Compressed air connection (quick release coupling)
- 9 Power supply
- 10 Condensate drain valve
- 11 Safety valve settings

The compressor draws in atmospheric air and compresses this air completely oil free. The oil-free compressed air is then transported directly to the pressure tank. The oil-free and hygienic air is stored in the pressure tank and can be made available to the consumer.



Mounting

9 Prerequisites

9.1 Area of installation

The installation area must fulfil the following requirements:

- Closed, dry, well ventilated room
- No purpose-built room (e. g. heating or wet room)
- Because of the amount of noise generated, we recommend that the unit be installed in an adjoining room.
- Set up the unit on a flat, horizontal and stable surface (take the weight of the unit into account).
- Set up the unit so that the model identification plate can be easily read and that the unit is easily accessible to personnel for operation and maintenance.
- Set up the unit so that the socket outlet to which the unit is connected is easily accessible.
- Set up the unit as near to the compressed air pipeline as possible (length of hose supplied is 3 m).
- Leave sufficient distance from any wall (approx. 20 cm).
- Comply with the environmental conditions "6 Technical data of compressor stations".



The air is filtered during the intake. The particular features of the air are unaffected. The source of the air taken in should be free of any harmful substances (e.g. do not draw in air from a basement garage or from directly next to a suction machine).



NOTICE

Risk of overheating due to insufficient ventilation

The unit gives off heat. This can lead to damage due to high temperatures and/or to a reduction in the service life of the compressor unit.

- Do not cover the unit.
- Install auxiliary ventilation for the room where ambient temperatures exceed 40 °C.

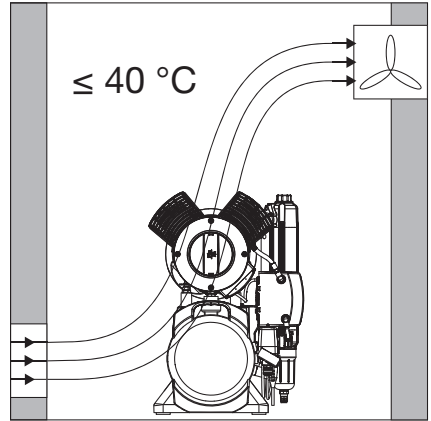

10 Transport



WARNING Explosion of pressure tank and pressure hoses

- Only store and transport the pressure tank and pressure hoses in a completely vented condition.
- Protect the unit from moisture, dirt and extreme temperatures during transport (see Ambient conditions).
- Only transport the unit when the condensate collecting chamber is empty ("15.1 Shut down the unit").
- Always transport the unit in an upright state.
- Only transport the unit using the intended carrying handles.

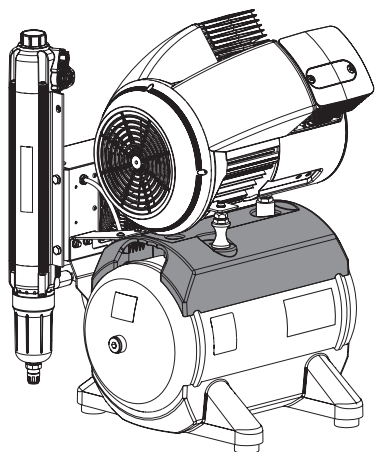
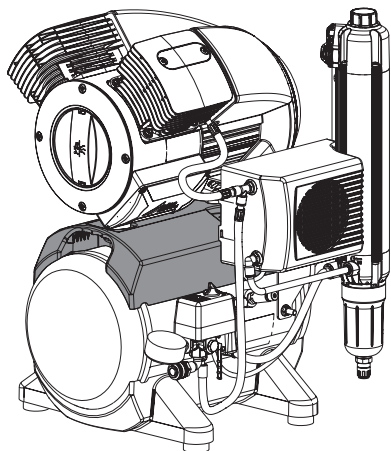

11 Operation

11.1 Remove the transport protection

For safe transport, the unit is securely protected with foam rubber padding protectors and a plastic transport strap.

- Cut the plastic transport strap and remove.
- Remove the foam rubber padding.

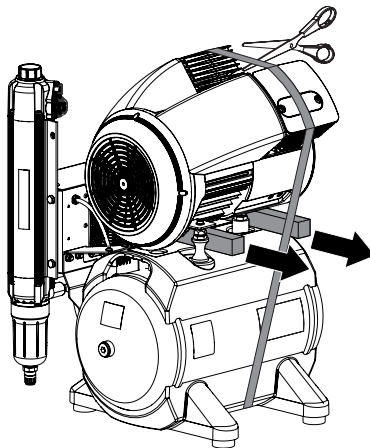

11.2 Set up compressed air connection



The flexible pressure hose supplied between the plumbing system and the compressor prevents the transmission of vibration and reduces noise. This ensures safe operation.

- Connect the connecting sleeve (premounted on the pressure hose) to the quick release coupling.
- Measure the required length of the pressure hose and shorten if necessary.
- Slide the second hose nozzle in place and secure with a hose clip.
- Connect the connecting sleeve on the pressure hose to the compressed air line.

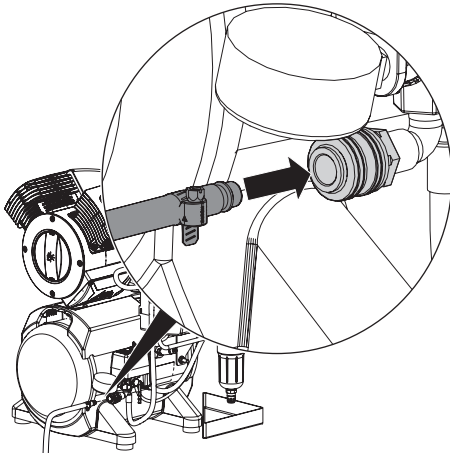

11.3 Place the collector tray underneath

During operation, condensate on the unit is constantly separated and automatically drained. In order to prevent water damage due to drained condensate, it is collected in the collector tray.



As an option, the condensate can be removed using a hose connected to the waste water system. Heed the national regulations for waste water systems.

- Place a collector tray under the condensate separator or the membrane drying unit (depending on type).

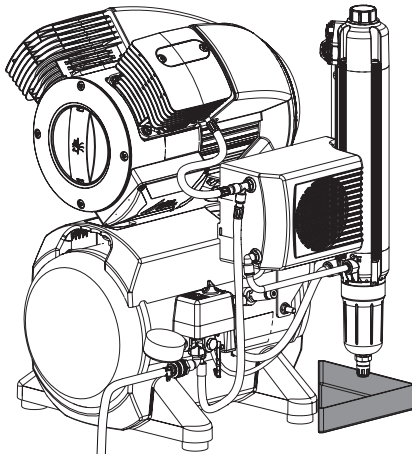

11.4 Electrical connection

Safety for the electrical connection

- The unit may only be connected to a correctly installed socket outlet.
- Make sure the connection lines to the unit are not subject to any mechanical tension.
- Before initial start-up, check the supply voltage with the voltage information on the model identification plate (see also "4. Technical Data").

Establish electrical connection



DANGER

Electric shock caused by defective mains cable

- Mains cable must not come into contact with the hot surfaces of the unit.
- Plug the female connector of the power cord into the corresponding male connector at the pressure switch.

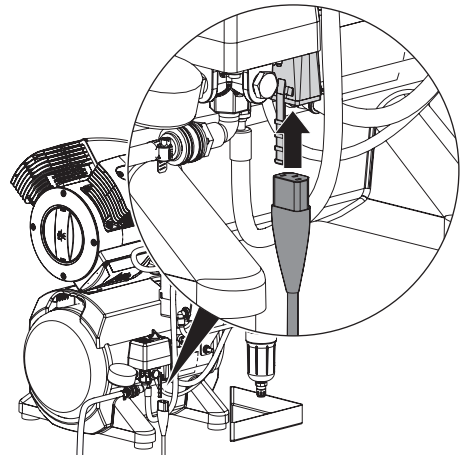

- Secure the female connector using the cable tie provided.

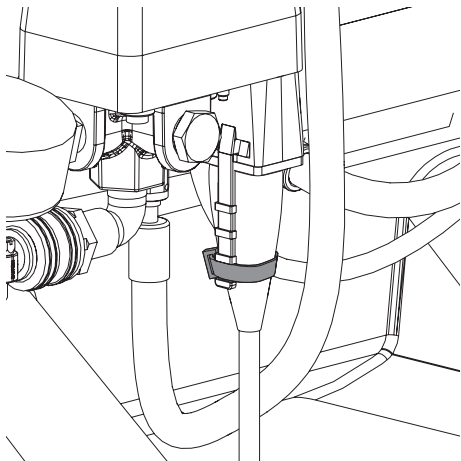

- Plug the mains power connector into an earthed power socket.

11.5 Check the motor protection switch

For compressors that must be operated at 100 - 127 V, the motor protection switch must be checked and adjusted if there are deviations. The motor protection switch is structurally combined with the pressure switch. This has been set to the recommended setting in the factory (see "6 Technical data of compressor stations"). Compressors that must be operated with 230 V, have a winding protector which cannot be set instead of a motor protection switch.

- Switch on the unit at the pressure switch by rotating this switch to the "I" position.

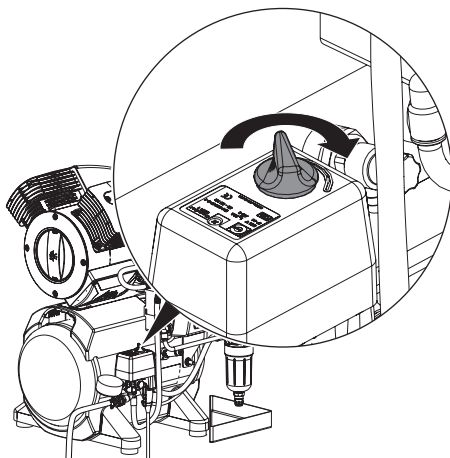

- Measure the rated current (value just before reaching the cut off pressure).

Result:

If the read value deviates from the recommended setting, the motor protection switch must be set (see "6 Technical data of compressor stations").

11.6 Checking the initial pressure/ cut off pressure

The initial pressure/cut off pressure is preset at the factory. Check the setting at start-up.

- Switch on the unit at the pressure switch by rotating this to the "I AUTO" position.
- Read off the cut off pressure at the pressure gauge.
- Drain air from the pressure tank (e. g. on the condensate drain valve) until the unit starts and then close again.
- Read the pressure when switching on the unit.

Result:

If the values read deviate from the values preset at the factory, adjust the pressure switch to the factory settings.

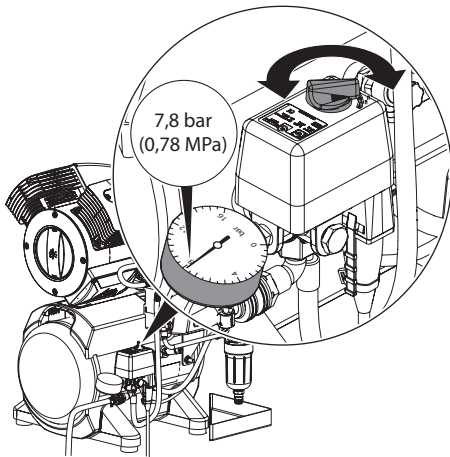

11.7 Check safety valve settings

The function of the safety valve must be checked when the unit is started up and at regular intervals.



The safety valve setting is set to 10 bar (1 hPa), checked and stamped as approved in the factory.



DANGER Explosion of the pressure tank and pressure hoses

- Do not change the safety valve settings.
- Switch on the unit at the pressure switch and fill the pressure tank to the cut off pressure.



WARNING Damage to the safety valve

Explosion of pressure tank and pressure hoses due to defective safety valve

- Do not use the safety valve to vent the pressure tank.
- To open, rotate the screw of the safety valve to the left until the valve begins to blow off. Only allow the safety valve to blow for a short period.
- Now turn the screw to the right as far as it goes to close the valve. The valve must now be closed again.

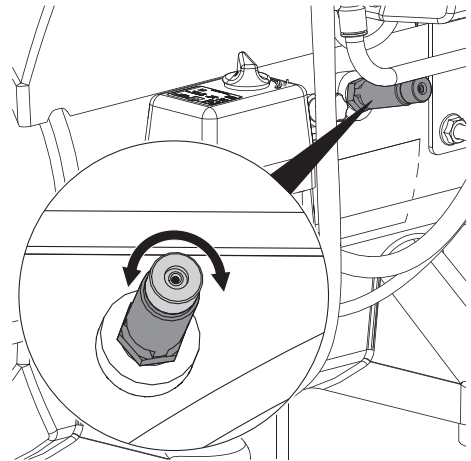

11.8 Draining the condensate

Temperature changes during transport may cause condensate to accumulate in the pressure receiver. The condensate can only be drained from the pressure receiver when it is pressurised.

- Switch on the device at the pressure switch and wait until the cut-out pressure has been reached.
- Close the condensate drain valve once the condensed water has run off completely.

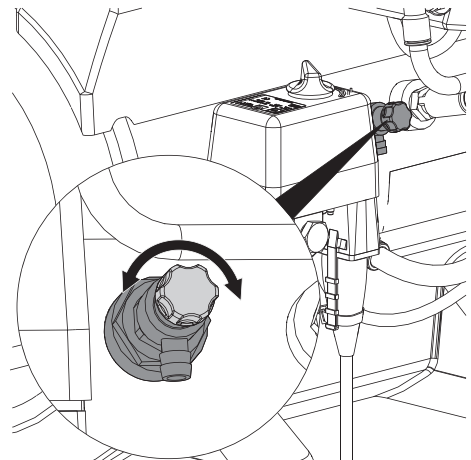

12 Setting possibilities

12.1 Pressure switch setting



DANGER

Bare parts subject to electrical current

Electric shock due to parts under electrical current

- Unplug the unit at the socket outlet.
- Use insulated tools.
- Do not come into contact with live parts.



The cut off pressure must be at least 0.5 bar (0,05 hPa) below the maximum pressure of the safety valve setting of 10 bar (1 hPa). Otherwise the safety valve can open too early, the cut off pressure will not be obtained and the compressor will run continuously. The maximum permitted pressure is marked by a red line on the pressure gauge provided.

Setting at 230 V

If the read values deviate from the factory settings or if other settings are required, the cut off pressure of the compressor can be adjusted using the setting screw on the pressure switch. The pressure difference Δp cannot be altered.

- Lift off the pressure switch unit cover.
- Set the cut off pressure p using the setting screw.

The arrow direction "+" means the cut off pressure is increased and the arrow direction "-" means the cut off pressure is decreased.

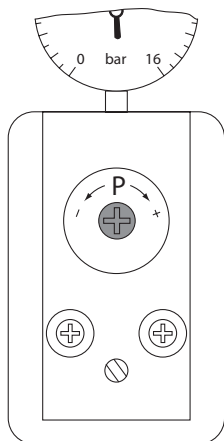

Setting at 110 - 127 V

If the values read off deviate from the factory settings or where other settings are required, the compressor cut off pressure can be altered by adjusting the setting screw on the pressure switch unit. The switch-on pressure can then be adjusted using pressure difference Δp .

- Lift off the pressure switch unit cover.
- Adjust the cut off pressure P at the setting screw.

The "+" arrow direction increases the cut off pressure and the "-" arrow direction decreases the cut off pressure. Pressure difference Δp is also influenced by this adjustment.

- Adjust the switch-on pressure using the pressure difference Δp at the setting screw.

The "+" arrow direction increases the pressure difference and the "-" arrow direction decreases it.

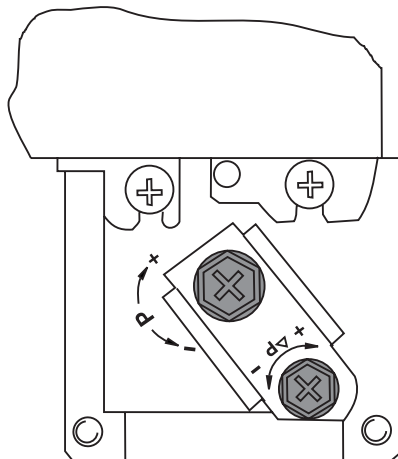



13 Instructions for use



Prior to working on the unit or in case of danger, disconnect it from the mains (e. g. pull the plug).

13.1 Switch the unit on/off

- Switch on the unit at the pressure switch by rotating this to the position "I AUTO".

The compressor unit will run automatically and the pressure tank will begin to fill. When the cut off pressure has been reached, the compressor unit switches itself off automatically.

- The unit can be switched off whenever required by turning the pressure switch to the "0 OFF" setting.

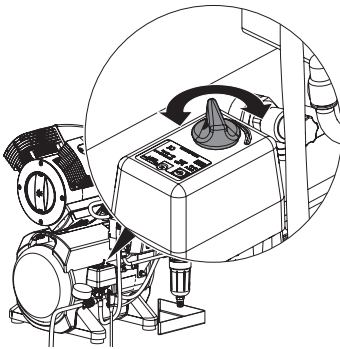

14 Maintenance



Prior to working on the unit or in case of danger, disconnect it from the mains (e. g. pull the plug).

14.1 Maintenance plan

Units without membrane drying unit

Maintenance interval	Maintenance work
Monthly	<ul style="list-style-type: none"> • Drain condensate - if humidity is high, daily.
Every six months	<ul style="list-style-type: none"> • Check safety valve.
Yearly	<ul style="list-style-type: none"> • Change air intake filter - every six months if dust concentration is high.
Every 4 years	<ul style="list-style-type: none"> • Replace vibration dampers.

Device with membrane drying unit

Maintenance interval	Maintenance work
Every six months	<ul style="list-style-type: none"> • Drain condensate. • Check the safety valve.
Annually	<ul style="list-style-type: none"> • Replace the air intake filter in the compressor unit every six months if there is a high concentration of dust. • Replace the fine or sterile filter. • Replace the sinter filter.
Every 4 years	<ul style="list-style-type: none"> • Replace the vibration reducer.
In accordance with the respective national law	<ul style="list-style-type: none"> • Carry out repeat safety inspections (e.g. pressure container inspection, electrical safety inspection) in accordance with the respective national law.

14.2 Change the air intake filter

Units without noise reducing hood

- Switch off the compressor at the pressure switch.
- Pull out the plug.
- Remove cover to filter unit by rotating **in clockwise direction** and unlocking.
- Remove the air intake filter.
- Insert a new air intake filter.
- Place filter unit cover back in position, turn in **clockwise direction** and lock.

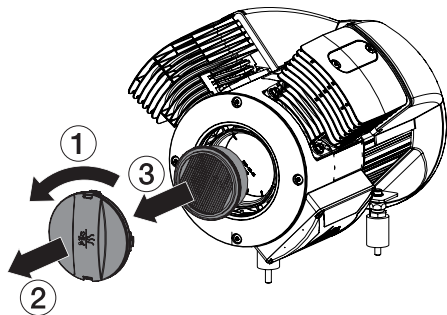

- Remove cover to filter unit by rotating **in clockwise direction** and unlocking.

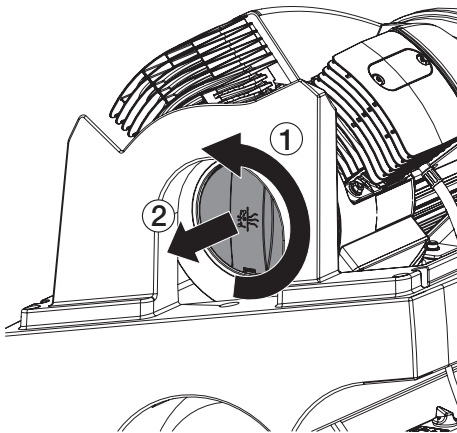

- Remove the air intake filter.

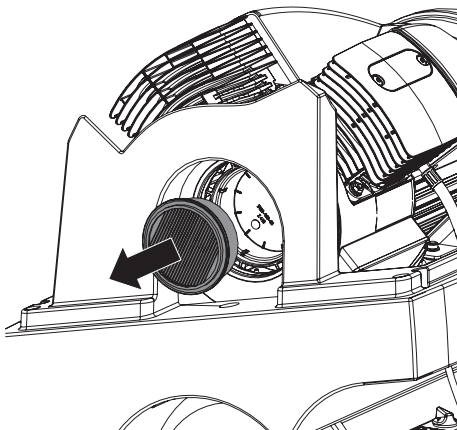

Units with noise reducing hood

- Switch off the compressor at the rotary switch of the pressure switch.
- Unplug at the mains and remove all power.
- Remove the noise reducing hood and foam filter cover.

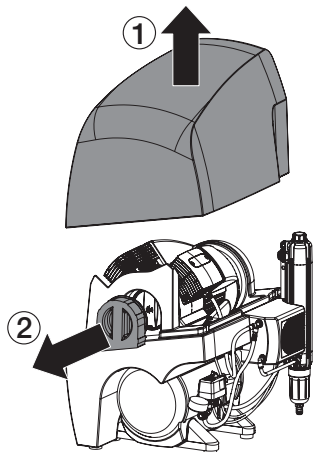

- Insert new air intake filter.
- Place filter unit cover back in position, turn in **clockwise direction** and lock.
- Mount the foam filter cover and noise reducing hood.

14.3 Replacing the filter of the membrane-drying unit

Fine/Sterile filter

- Switch off the unit.
- Pull out the plug.
- Unscrew and remove the filter cover.
- Remove the fine/sterile filter.
- Insert the new fine/sterile filter.

- Replace the filter cover and close.

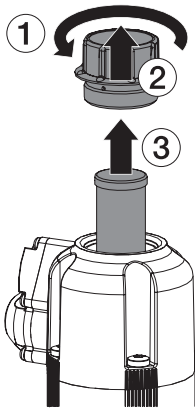

Sinter filter

- Unscrew and remove the filter housing.
- Remove the sinter filter.
- Insert a new sinter filter.
- Replace the filter housing and close.

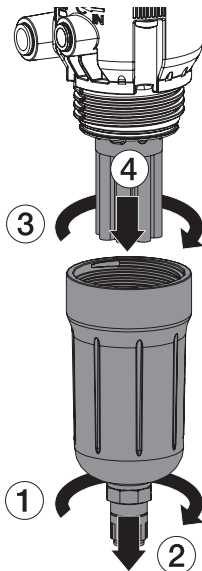

15 Deactivation

15.1 Shut down the unit

If the unit is not to be used for a prolonged period of time, it is recommended to decommission it.

To do so, the condensate accumulating from the unit must be drained.

- Switch on the unit and wait until the cut off pressure is reached.

Membrane drying unit

- Open the condensate drain valve on the membrane drying unit as long as the compressor unit is running. When no more condensate emerges, close the condensate drain valve.
- Switch off the unit.

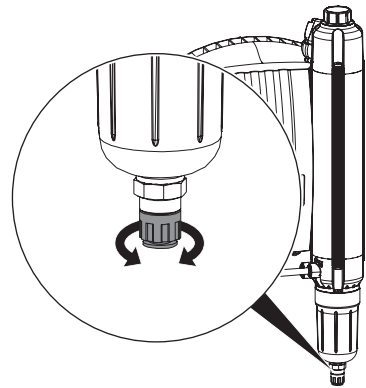

Pressure receiver

- Open the condensate drain valve. After the switch-on pressure has been reached, the compressor switches on.
- In switched-on compressors and with an opened condensate drain valve, wait until no more condensed water comes out.
- Switch off the compressor.
- Allow the complete pressure to vent off. Close the condensate drain valve.
- Unplug at the mains and remove all power.
- Separate the compressor from the plumbing lines.

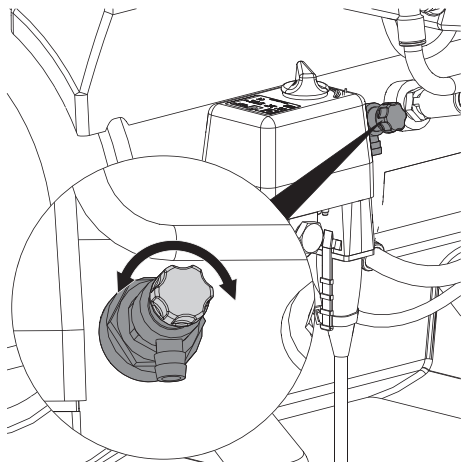

15.2 Store the unit



WARNING

Explosion of pressure tank and pressure hoses

- Only store and transport the pressure tank and pressure hoses in a completely vented condition.
- Protect device against moisture, soiling and extreme temperatures during storage (see ambient conditions).
- Only store the device when it is completely emptied.



Trouble-shooting

16 Tips for Operators and Technicians



Repairs above and beyond simple maintenance may only be carried out by a qualified technician or one of our service technicians.



Prior to working on the unit or in case of danger, disconnect it from the mains (e. g. pull the plug).

Problem	Probable cause	Solution
Compressor does not run	No mains voltage	<ul style="list-style-type: none"> • Check the mains fusing, if necessary switch on unit again. If the cut-out fuse is defective, replace.
	Undervoltage or overvoltage	<ul style="list-style-type: none"> • Measure the supply voltage; if necessary, call an electrician.
	Pressure switch not switched on	<ul style="list-style-type: none"> • Switch pressure switch on. • Inform the service technician.
Compressor does not switch off	Compressor is too small, air consumption too high	<ul style="list-style-type: none"> • Calculate the amount of air required (up to 50 l/min per treatment unit), if necessary install a larger compressor.
	Leak in the pressure pipe system	<ul style="list-style-type: none"> • Find leak and seal. • Inform service technician.
	Defective membrane drying unit	<ul style="list-style-type: none"> • Check whether there is an increased flow of air at the filter housing to the membrane drying unit (below), replace membrane drying unit if necessary.
Compressor switches on periodically without any air being used for equipment	Leak in the pressure pipe system	<ul style="list-style-type: none"> • Find leak and seal. • Inform service technician.
Knocking or loud noises caused by compressor	Compressor unit defective	<ul style="list-style-type: none"> • Pull out the plug and inform a service technician.
Delivery decreasing. Compressor needs longer to charge the pressure tank, see charge times in "6 Technical data of compressor stations"	Air intake filter dirty	<ul style="list-style-type: none"> • Replace the air intake filter at least 1x year. Do not attempt to clean the air intake filter.
	Defective membrane drying unit	<ul style="list-style-type: none"> • Replace membrane drying unit. • Inform the service technician.
Water leaks from equipment served by air	Maintenance work not carried out regularly (without membrane drying unit)	<ul style="list-style-type: none"> • Regularly drain the condensate from the pressure tank, see "11.8 Draining the condensate"
	Defective membrane drying unit	<ul style="list-style-type: none"> • Inform the service technician.

17 Tips for service technicians



The following information on troubleshooting is exclusively for service technicians. Repairs may only be carried out by suitably qualified service technicians.



Prior to working on the unit or in case of danger, disconnect it from the mains (e. g. pull the plug).

Problem	Probable cause	Solution
Compressor does not run	No supply voltage. For three-phase alternating current generators: one phase is missing or is not switched on (humming noises)	<ul style="list-style-type: none"> • Check the mains fusing, switch on unit again if necessary. If the cut-out fuse is defective, replace. Check supply voltage.
	Under or overvoltage	<ul style="list-style-type: none"> • Measure the supply voltage, call an electrician if necessary.
	Bleeder valve defective, generator is working against pressure	<ul style="list-style-type: none"> • Check whether the bleeder valve (9/19) blows off air after the generator has switched off. Ensure bleeder valve operates or replace.
	Running of generator indicates mechanical resistance (piston blocked); motor protection switch activated	<ul style="list-style-type: none"> • Pull the mains plug, remove the fan cover of the blocked compressor and turn the fan wheel. If this is not possible, replace the piston and cylinder or complete generator.
Humming noise from motor	Motor capacitor is defective	<ul style="list-style-type: none"> • Replace the capacitor.



Addresses

Service

Dürr Technik GmbH & Co. KG
74301 Bietigheim-Bissingen
Tel +49 (0)71 4290 2220
Fax +49 (0)71 4290 2299
E-mail: service@duerr-technik.de

Spare parts orders

Tel +49 (0)71 4290 0
Fax +49 (0)71 4290 99
E-mail: office@duerr-technik.de

Please provide the following information when ordering spare parts:

- Type code and article number
- Order number as appears on the spare parts list
- Quantity required
- Exact shipping address
- Shipping information

Repairs / returns

Please **depressurise** the unit before transporting it. If possible, please use the original packaging when returning units. Always pack the units in a plastic bag. Please use recyclable packing material.

Return address

Dürr Technik GmbH & Co. KG
Pleidelsheimer Straße 30
74321 Bietigheim-Bissingen
-Germany-

International addresses for Dürr Technik

www.duerr-technik.com

Dürr Technik GmbH & Co. KG
Pleidelsheimer Strasse 30
74321 Bietigheim-Bissingen
Germany
Fon: +49 7142-90 22 -0
www.duerr-technik.com
office@duerr-technik.de

