

# Oil-free piston compressors KK and piston vacuum pumps KV

EN

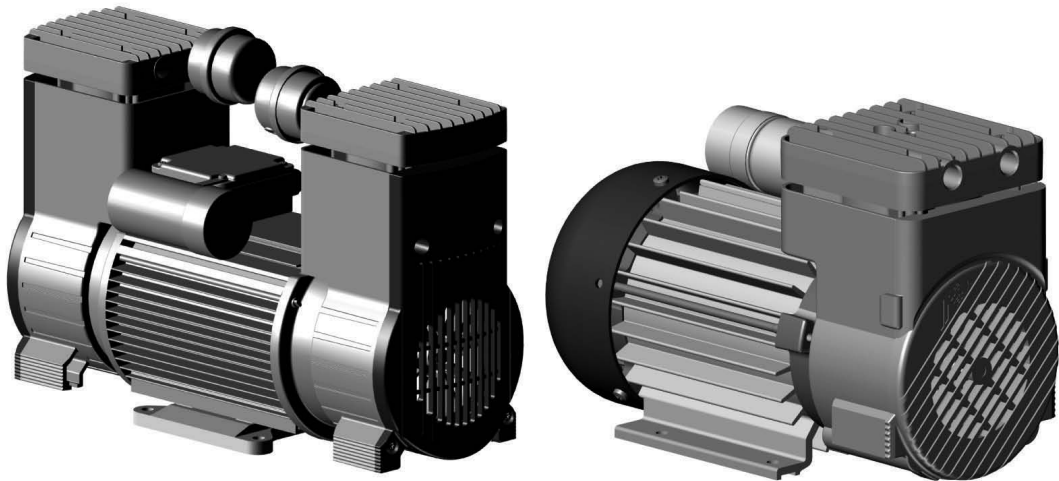

Installation and Operating Instructions



0678106030L02



1707V003



# Contents



## Important information

<b>1 About this document</b> . . . . .	2
1.1 Warnings and symbols . . . . .	2
1.2 Copyright information . . . . .	2
<b>2 Safety</b> . . . . .	3
2.1 Intended use . . . . .	3
2.2 Improper use . . . . .	3
2.3 General safety information . . . . .	3
2.4 Qualified personnel . . . . .	3
2.5 Protection from electric shock . . . . .	3
2.6 Only use genuine parts . . . . .	3
2.7 Transportation and storage . . . . .	3
2.8 Disposal . . . . .	3



## Product description

<b>3 Overview</b> . . . . .	4
3.1 Oil-free piston compressors KK . . . . .	4
3.2 Oil-free piston vacuum pumps KV . . . . .	4
3.3 Accessories . . . . .	4
3.4 Spare parts set . . . . .	4
<b>4 Oil-free piston compressors and piston vacuum pumps series KK8 / KV8</b> . . . . .	5
4.1 Accessories for piston compressors KK . . . . .	5
4.2 Accessories for piston vacuum pumps KV . . . . .	6
4.3 Spare parts set for type KK8 / KV8 . . . . .	7
4.4 Schematic drawing KK8/KV8 . . . . .	8
4.5 Performance diagram KK8 . . . . .	9
4.6 Performance diagram KV8 . . . . .	10
4.7 Technical data KK8 . . . . .	11
4.8 Technical data for piston vacuum pumps KV8 . . . . .	13
<b>5 Oil-free piston compressors and piston vacuum pumps series KK15 / KV15</b> . . . . .	15
5.1 Accessories for piston compressors KK . . . . .	15
5.2 Accessories for piston vacuum pumps KV . . . . .	16
5.3 Spare parts set for type KK15/KV15 . . . . .	17
5.4 Schematic drawing KK15/KV15 . . . . .	18
5.5 Performance diagram KK15 . . . . .	19
5.6 Performance diagram KV15 . . . . .	20
5.7 Technical data for piston compressors KK15 . . . . .	21
5.8 Technical data for piston vacuum pumps KV15 . . . . .	31
<b>6 Oil-free piston compressors and piston vacuum pumps series KK40 / KV40</b> . . . . .	35
6.1 Accessories for piston compressors KK . . . . .	35
6.2 Accessories for piston vacuum pumps KV . . . . .	36
6.3 Schematic drawing KK40 / KV40 . . . . .	37
6.4 Spare parts set for type KK40 / KV40 . . . . .	39
6.5 Performance diagram KK40 . . . . .	40
6.6 Performance diagram KV40 . . . . .	41
6.7 Technical data for piston compressors KK40 . . . . .	42
6.8 Technical data for piston vacuum pumps KV40 . . . . .	46

<b>7 Oil-free piston compressors series KK70</b> . . . . .	48
7.1 Accessories for piston compressors KK . . . . .	48
7.2 Spare parts set for type KK70 . . . . .	49
7.3 Schematic drawing KK70 . . . . .	50
7.4 Performance diagram KK70 . . . . .	51
7.5 Technical data for piston compressors KK70 . . . . .	52
<b>8 Declaration of conformity for machines in accordance with the 2006/42/EC Directive</b> . . . . .	57
<b>9 Operation</b> . . . . .	58
9.1 Oil-free piston compressors KK . . . . .	58
9.2 Oil-free piston vacuum pumps KV . . . . .	58



## Installation

<b>10 Requirements</b> . . . . .	59
10.1 Installation/setup room . . . . .	59
10.2 Vibration dampening . . . . .	59
10.3 Installation position and fastening . . . . .	59
10.4 Silencer . . . . .	59
<b>11 Electrical installation</b> . . . . .	60
11.1 Electrical connection using a mains plug . . . . .	60
11.2 Electrical connection without a mains plug . . . . .	60
11.3 IP protection type . . . . .	60
11.4 Direction of rotation . . . . .	60
11.5 Fuse protection of the supply current circuit . . . . .	60
11.6 Motor protection - temperature . . . . .	60
11.7 Circuit diagrams . . . . .	62
<b>12 Commissioning and first start-up</b> . . . . .	67
12.1 Remove the transport locks . . . . .	67
12.2 Connect oil-free piston compressor . . . . .	67
12.3 Connecting oil-free piston vacuum pumps . . . . .	67
<b>13 Maintenance</b> . . . . .	68
13.1 Maintenance schedule . . . . .	68



## Troubleshooting

<b>14 Units for alternating current</b> . . . . .	70
<b>15 Units for direct current</b> . . . . .	71



## Addresses



# Important information

## 1 About this document

These installation and operating instructions represent a part of the unit. They correspond to the relevant version of the unit and the status of technology valid at the time of its market launch.



In the event that the instructions and notes in these installation and operating instructions for are not observed, Dürr Technik accepts no warranty or liability of any kind for the safe operation and reliable function of the units.

This translation was prepared to the best of our knowledge. The original German language version of the manual is the definitive version. Dürr Technik is not liable for translation errors.

### 1.1 Warnings and symbols

#### Warnings

The warnings in this document are intended to draw your attention to possible injury to persons or damage to machinery.

The following warning symbols are used:



General warning symbol



Warning – dangerous high voltage



Warning – hot surfaces



Warning - automatic start-up of the unit

The warnings are structured as follows:



#### SIGNAL WORD

##### Description of the type and source of danger

Here you will find the possible consequences of ignoring the warning

> Follow these measures to avoid the danger.

The signal word differentiates between four levels of danger:

#### – DANGER

Immediate danger of severe injury or death

#### – WARNING

Possible danger of severe injury or death

#### – CAUTION

Risk of minor injuries

#### – NOTICE

Risk of extensive material/property damage

#### Other symbols

These symbols are used in the document and on or in the unit:



Note, e.g. specific instructions regarding efficient and cost-effective use of the unit.



Comply with the specification in the accompanying documents.



CE labelling



Dispose of the unit properly and in accordance with applicable national, regional and local laws.



Switch off and de-energise the unit (e.g. unplug from mains).

### 1.2 Copyright information

All names of circuits, processes, names, software programs and units used in this document are protected by copyright.

The reprinting of the installation and operating instructions, even in extracts, is only permitted with the written permission of Dürr Technik.

## 2 Safety

Dürr Technik has developed and constructed the units in such a way that danger is to a large extent excluded if the units are used as intended. Nevertheless, residual risks can remain. You should therefore observe the following notes.

### 2.1 Intended use

#### Oil-free piston compressors KK

The unit is intended for the compression of atmospheric air. The unit has been designed for installation into systems and machines. It may only be commissioned after the manufacturer of the system made sure that all requirements ensuring safe operation have been met.

The unit has been designed for operation in dry, ventilated rooms. The unit must not be operated in a damp or wet environment. Its use in the vicinity of gases or flammable liquids is prohibited.

#### Oil-free piston vacuum pumps KV

The unit is intended for the aspiration of atmospheric air. The unit has been designed for installation into systems and machines. It may only be commissioned after the manufacturer of the system/unit has ensured that all requirements requisite to safe operation have been fulfilled.

The unit has been designed for operation in dry, ventilated rooms. The unit must not be operated in a damp or wet environment. Its use in the vicinity of gases or flammable liquids is prohibited.

### 2.2 Improper use

Any other usage or usage beyond this scope is deemed to be improper. The manufacturer accepts no liability for damages resulting from this. In these cases the user/operator will bear the sole risk.



#### WARNING

**Serious injury and material damage due to improper usage**

- › Conveying explosive mixtures in any way other than that specified is not permitted.

### 2.3 General safety information

- › When operating this device always observe all guidelines, laws, and other rules and regulations that are applicable at the site of operation.
- › Prior to each use, check condition of the device and make sure it is in perfect working order.
- › Do not convert or modify the units.
- › Observe the Installation and Operating Instructions.
- › Make the Installation and Operating Instructions available to the person operating the device at all times.

### 2.4 Qualified personnel

#### Operation

Persons who operate the units must ensure safe and correct handling based on their training and knowledge.

- › Instruct or have every user instructed in handling the unit.

#### Installation and repairs

- › Always arrange for any assembly work, readjustments, alterations, extensions, and repairs to be performed by Dürr Technik or by personnel authorised and trained by Dürr Technik. Qualified personnel are defined as those trained by Dürr Technik; who are familiar with the unit technology; and are aware of the dangers presented by the unit.

### 2.5 Protection from electric shock

- › When working on the units observe all the relevant electrical safety regulations.
- › Immediately replace any damaged cables or plugs.

### 2.6 Only use genuine parts

- › Only use accessories and special accessories that are specified or approved by Dürr Technik.
- › Only use original working and spare parts.



Dürr Technik accepts no liability for damage resulting from the use of non-approved accessories, special accessories or any working parts or spare parts other than original parts.

### 2.7 Transportation and storage

The original packaging provides optimum protection for the unit during transport.



Dürr Technik will not accept any responsibility or liability for damage occurring during transport due to the use of incorrect packaging, even where the unit is still under guarantee.

- Only transport the unit in its original packaging.
  - Keep the packing materials out of the reach of children.
- The unit may be stored in its original packaging
- in warm, dry and dust-free rooms;
  - protected from contaminants.



If possible, retain the packaging material.

#### Ambient conditions during storage and transport

##### Ambient conditions during storage and transport

Temperature	°C	-25 to +55
Rel. humidity	%	10 % to 90 %

Please refer to the labels on the packaging padding.

### 2.8 Disposal

#### Unit



Dispose of the unit properly and in accordance with applicable national, regional and local laws.

#### Packaging



Dispose of the packaging material in an environmentally responsible manner.

- Note current disposal routes.
- Keep the packing materials out of the reach of children.



## 3 Overview

### 3.1 Oil-free piston compressors KK

The oil-free piston compressors in the series KK8, KK15, KK40 and KK70 each consist of a compressor head with an electric motor.

The following electric motors are available:

Type A	Single-phase ac motors
Type B	Three-phase motors
Type D	DC permanent-magnet motors

### 3.2 Oil-free piston vacuum pumps KV

The oil-free piston vacuum pumps in the series KV8, KV15 and KV40 each consist of a vacuum head with an electric motor.

The following electric motors are available:

Type A	Single-phase ac motors
Type B	Three-phase motors
Type D	DC permanent-magnet motors

### 3.3 Accessories

Regarding the use of piston compressors and piston vacuum pumps, Dürr Technik offers a broad range of powerful accessory components.



The intake air must be filtered. To this end, a suitable air intake filter must be mounted on the air inlet of the unit.



The unit generates vibrations. Suitable vibration dampers must be installed on the unit to dampen these vibrations.

Depending on the application area and the particular series, product-specific air intake filters, noise reducers and vibration dampers are available (see "Accessories for piston compressors KK" and "Accessories for piston vacuum pumps KV" for the relevant series).

The accessory parts are not part of the standard scope of delivery and need to be ordered separately.

### 3.4 Spare parts set





Any repairs above and beyond routine maintenance must only be carried out by suitably qualified personnel or by one of our service technicians.

Product-specific spare parts sets are available for repairs to piston compressors. The article numbers for the spare parts sets are listed in the "Technical data" section under the relevant unit.

## 4 Oil-free piston compressors and piston vacuum pumps series KK8 / KV8

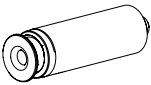
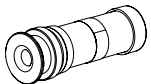
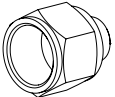
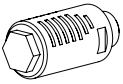
### 4.1 Accessories for piston compressors KK

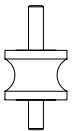

Filter and noise reducer				
	Description		Technical data	Remark
	Air intake filter, long	0714200040	G1/4" 3 µm filter mesh size	– complete, including air intake filter cartridge – Order a reduction nipple at the same time
	Air intake filter cartridge, long	0714200050	3 µm filter mesh size	– Fits air intake filter long
	Reduction nipple G1/4" -> G1/8"	9000-310-57	G1/4 " --> G1/8"	– Order at the same time for assembly on KK8 / KV8
	Air intake filter / noise reducer G1/8"	0714200060	G1/8"	

Vibration damper				
	Description		Technical data	Connector 1 / Connector 2
	Vibration damper set (33 sh)	0536100005	Ø25x20 Hardness: 33 Shore	M6x12/ M6x18
	Vibration damper set (70 sh)	0536100007	Ø20x30 Hardness: 70 Shore	M4x6/ M4 internal

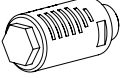
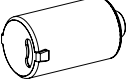
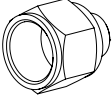

## 4.2 Accessories for piston vacuum pumps KV

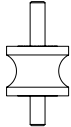
Filter and noise reducer				
	Description		Technical data	Remark
	Air intake filter / noise reducer G1/8"	0714200060	G1/8"	
	Air intake filter / noise reducer G1/4"	0714200070	G1/4"	- Order a reduction nipple at the same time
	Reduction nipple G1/4" -> G1/8"	9000-310-57	G1/4 " --> G1/8"	- Order at the same time for assembly on KK8 / KV8

Vibration damper				
	Description		Technical data	Connector 1 / Connector 2
	Vibration damper set (33 sh)	0536100005	Ø25x20 Hardness: 33 Shore	M6x12/ M6x18
	Vibration damper set (70 sh)	0536100007	Ø20x30 Hardness: 70 Shore	M4x6/ M4 internal



### 4.3 Spare parts set for type KK8 / KV8

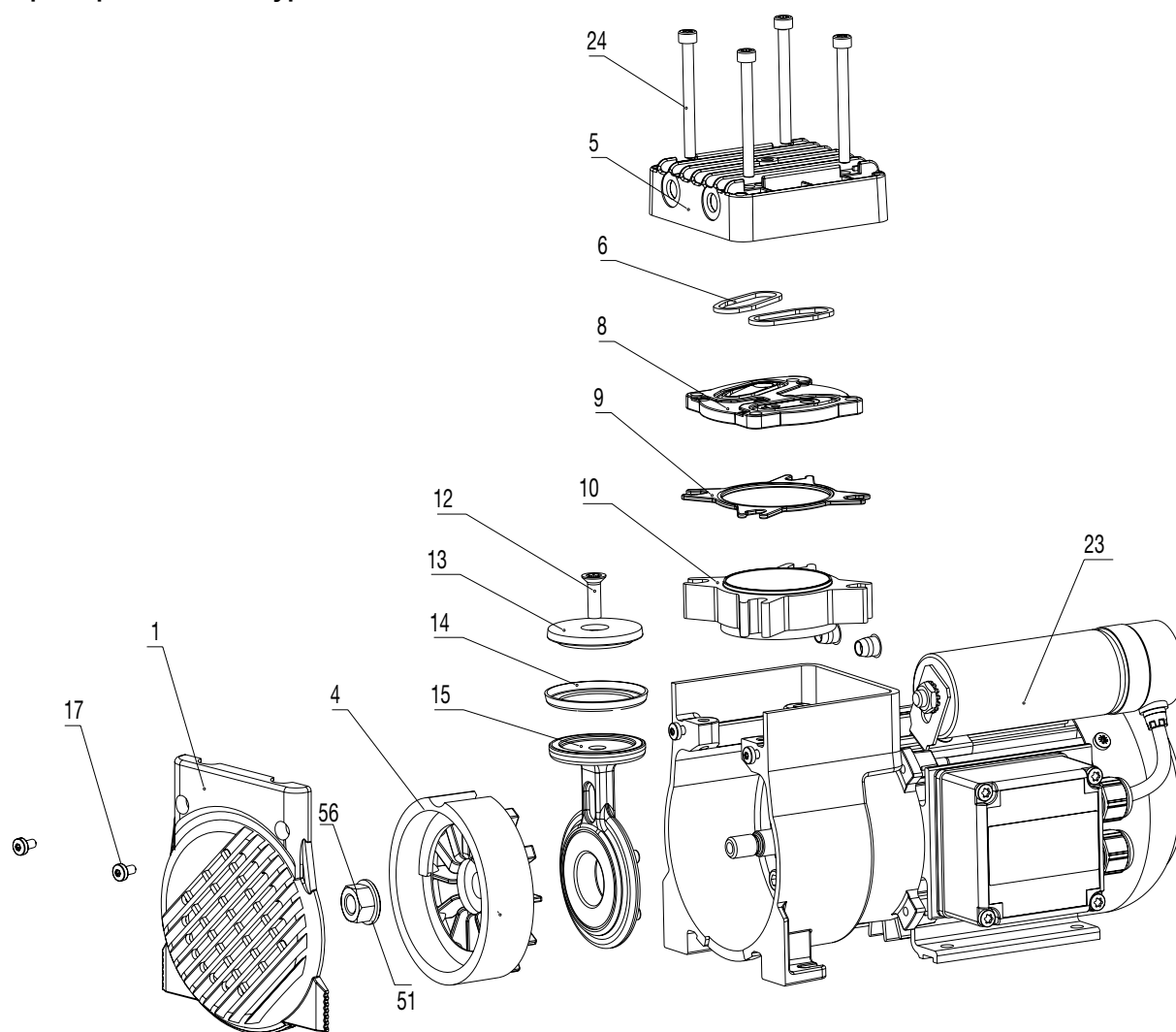

Figure 1: Oil-free piston compressors and piston vacuum pumps KK8 / KV8 with item numbers for spare parts

#### 4.4 Schematic drawing KK8/KV8

**i** The dimensions (diameter, height) of the vibration dampers are product-specific (refer to the "Accessories – Technical data" section). If different vibration dampers to the ones shown are used then their dimensions will change.

EN

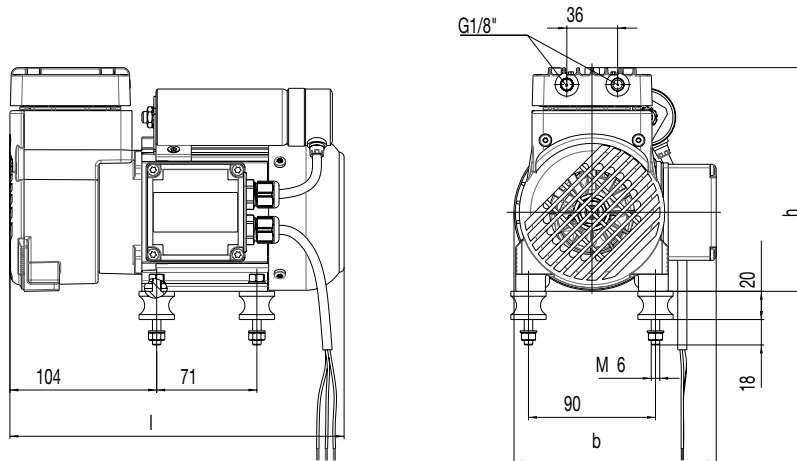

Figure 2: KK8 / KV8; Type: A-025; A-025E

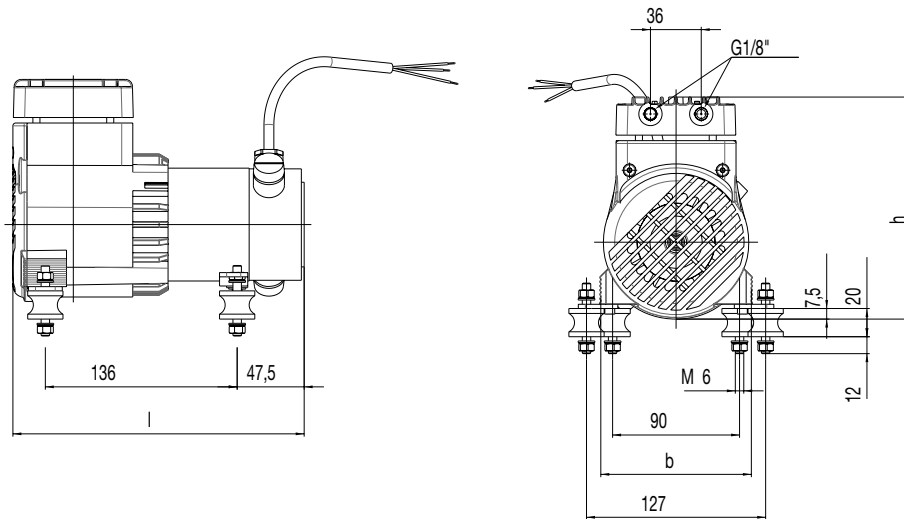

Figure 3: KK8 / KV8; Type: D-030; D-030E

#### 4.5 Performance diagram KK8

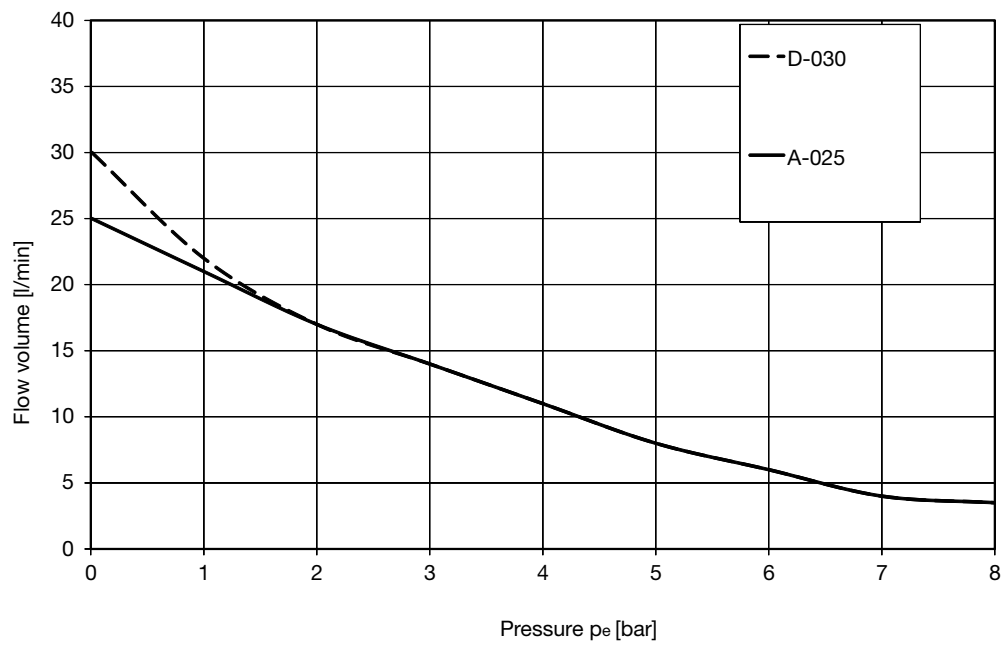

Figure 4: Delivery quantity at 50 Hz (60 Hz approx. +18%)



### 4.6 Performance diagram KV8

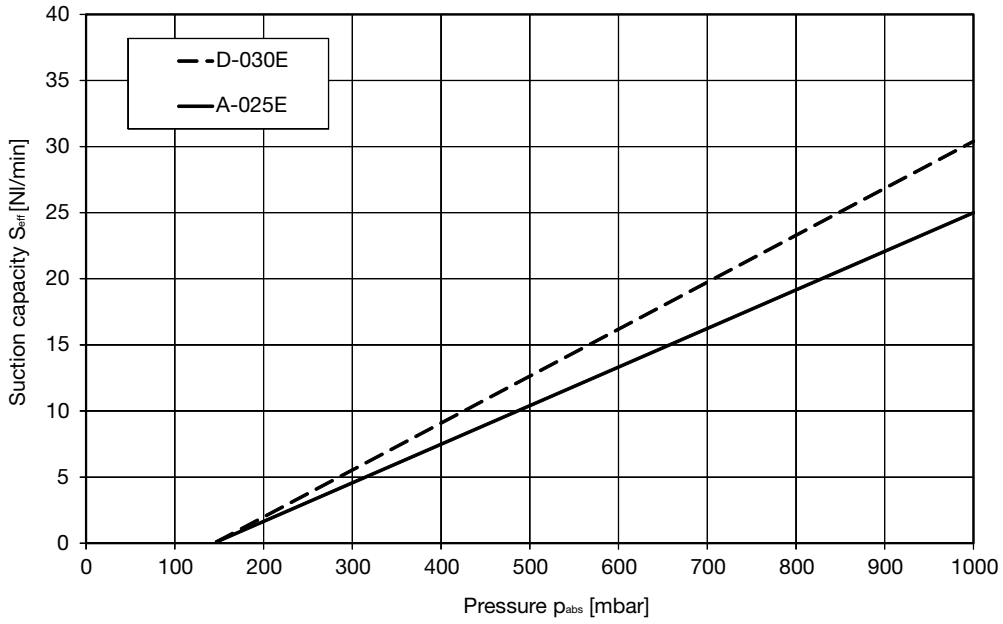

Figure 5: Suction capacity based on atmospheric pressure at 50 Hz (60 Hz approx. +18%)

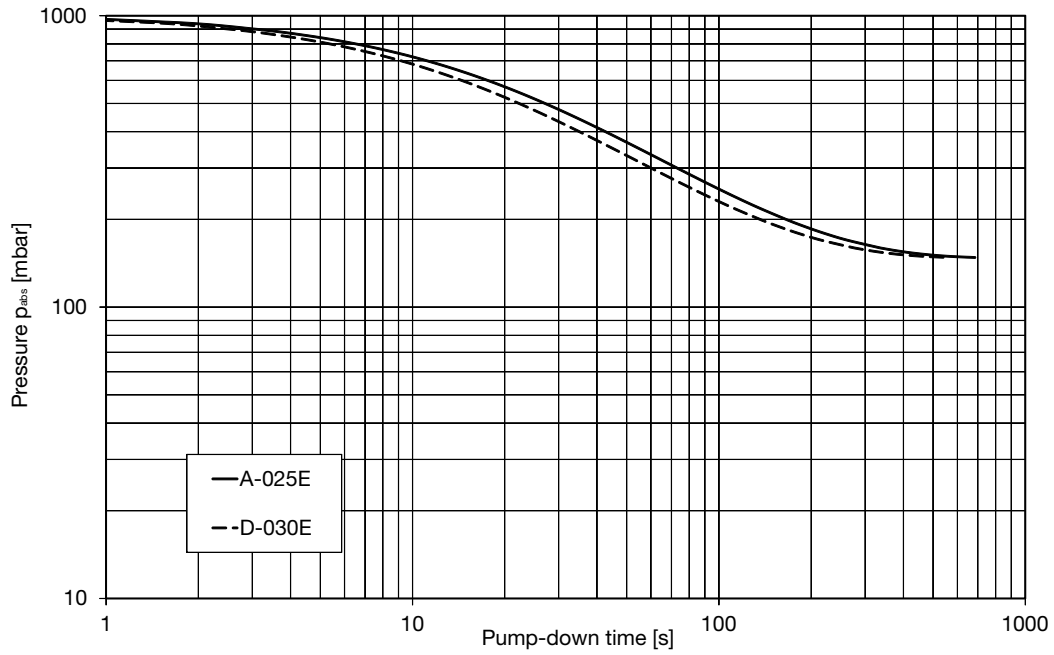

Figure 6: Pump-down time for a 10-l volume at 50 Hz

EN

## 4.7 Technical data KK8

### Type A-025

Electrical data			
Type	A-025		
Article no.	0536 1030		
Electrical frequency	Hz	50	60
Nominal voltage	V	110/115	110/115
Rated power	P1 (W)	180	200
Nominal current	A	1.7	1.8
Speed	min <sup>-1</sup>	1400	1660
Duty cycle	%	100	100
Type of protection (motor)	IP	54	54

General technical data			
Delivery quantity 0 bar	l/min	25	28
Nominal pressure	bars	7	7
Safety pressure PS	bars	10	10
Noise level	dB(A)	55	57
Weight	kg	4.8	4.8
Dimensions (LxWxH)	mm	237 x 143 x 159	237 x 143 x 159

Ambient conditions during operation			
temperature	°C	+5 to +40	+5 to +40

Spare part sets	Number re-quired	Item (see "4.3 Spare parts set for type KK8 / KV8")
Crankcase cover 0536100001	1	1, 17
Crankshaft with piston 0536100002	1	4, 6, 9, 10, 12, 13, 14, 15, 17, 51, 56
Valve plate with lamellar valves 0536100003	1	6, 8, 24
Head Kit 0536100004	1	6, 9, 10, 12, 14, 17, 24
Capacitor 20 µF 0536100011	1	23

### Type A-025

Electrical data			
Type	A-025		
Article no.	0536 1130		
Electrical frequency	Hz	50	60
Nominal voltage	V	230	230
Rated power	P1 (W)	220	270
Nominal current	A	1	1.2
Speed	min <sup>-1</sup>	1400	1600
Duty cycle	%	100	100
Type of protection (motor)	IP	54	54

General technical data			
Delivery quantity 0 bar	l/min	25	28
Nominal pressure	bars	7	7
Safety pressure PS	bars	10	10
Noise level	dB(A)	55	57
Weight	kg	4.8	4.8
Dimensions (LxWxH)	mm	237 x 143 x 159	237 x 143 x 159

Ambient conditions during operation			
temperature	°C	+5 to +40	+5 to +40

Spare part sets	Number re-quired	Item (see "4.3 Spare parts set for type KK8 / KV8")
Crankcase cover 0536100001	1	1, 17
Crankshaft with piston 0536100002	1	4, 6, 9, 10, 12, 13, 14, 15, 17, 51, 56
Valve plate with lamellar valves 0536100003	1	6, 8, 24
Head Kit 0536100004	1	6, 9, 10, 12, 14, 17, 24
Capacitor 20 µF 0536100011	1	23



## Type D-030

Electrical data		
Type	D-030	
Article no.	0825-02	
Electrical frequency	Hz	-
Nominal voltage	V	12 VDC
Rated power	P1 (W)	190
Nominal current	A	15.5
Speed	min <sup>-1</sup>	1850
Duty cycle	%	100
Type of protection (motor)	IP	00

General technical data		
Delivery quantity 0 bar	l/min	30
Nominal pressure	bars	7
Safety pressure PS	bars	10
Noise level	dB(A)	61
Weight	kg	4.4
Dimensions (LxWxH)	mm	209 x 108 x 156

Ambient conditions during operation		
temperature	°C	+5 to +40

Spare part sets	Number re-quired	Item (see "4.3 Spare parts set for type KK8 / KV8")
Crankcase cover 0536100001	1	1, 17
Crankshaft with piston 0536100002	1	4, 6, 9, 10, 12, 13, 14, 15, 17, 51, 56
Valve plate with lamellar valves 0536100003	1	6, 8, 24
Head Kit 0536100004	1	6, 9, 10, 12, 14, 17, 24
Carbon brushes (12 V) 0536100008	1	-
Sealing cap 0536100010	1	-

## Type D-030

Electrical data		
Type	D-030	
Article no.	0825-03	
Electrical frequency	Hz	-
Nominal voltage	V	24 VDC
Rated power	P1 (W)	120
Nominal current	A	6.4
Speed	min <sup>-1</sup>	1570
Duty cycle	%	100
Type of protection (motor)	IP	00

General technical data		
Delivery quantity 0 bar	l/min	30
Nominal pressure	bars	7
Safety pressure PS	bars	10
Noise level	dB(A)	61
Weight	kg	4.4
Dimensions (LxWxH)	mm	209 x 108 x 156

Ambient conditions during operation		
temperature	°C	+5 to +40

Spare part sets	Number re-quired	Item (see "4.3 Spare parts set for type KK8 / KV8")
Crankcase cover 0536100001	1	1, 17
Crankshaft with piston 0536100002	1	4, 6, 9, 10, 12, 13, 14, 15, 17, 51, 56
Valve plate with lamellar valves 0536100003	1	6, 8, 24
Head Kit 0536100004	1	6, 9, 10, 12, 14, 17, 24
Carbon brushes (24 V) 0536100009	1	-
Sealing cap 0536100010	1	-

## 4.8 Technical data for piston vacuum pumps KV8

### Type A-025E

Electrical data			
Type	A-025E		
Article no.	0536 2130		
Electrical frequency	Hz	50	60
Nominal voltage	V	115	115
Rated power	P1 (W)	120	120
Nominal current	A	1.2	1.2
Speed	min <sup>-1</sup>	1460	1750
Duty cycle	%	100	100
Type of protection (motor)	IP	54	54

General technical data			
Suction capacity $S_{eff}$	l/min	25	28
End pressure $P_{abs}$	mbar	<150	<150
Noise level	dB(A)	55	57
Weight	kg	4.8	4.8
Dimensions (LxWxH)	mm	237 x 143 x 159	237 x 143 x 159

Ambient temperature during operation		
temperature	°C	+5 to +40

Spare part sets	Number re-quired	Item (see "4.3 Spare parts set for type KK8 / KV8")
Crankcase cover 0536100001	1	1, 17
Crankshaft with piston 0536100002	1	On request
Valve plate with lamellar valves 0536100003	1	6, 8, 24
Head Kit 0536100004	1	6, 9, 10, 12, 14, 17, 24
Capacitor 20 µF 0536100011	1	23

### Type D-030E

Electrical data		
Type	D-030E	
Article no.	0826-02	
Electrical frequency	Hz	-
Nominal voltage	V	12 VDC
Rated power	P1 (W)	80
Nominal current	A	6.7
Speed	min <sup>-1</sup>	1750
Duty cycle	%	100
Type of protection (motor)	IP	00

General technical data		
Suction capacity $S_{eff}$	l/min	30
End pressure $P_{abs}$	mbar	<180
Noise level	dB(A)	53
Weight	kg	4.4
Dimensions (LxWxH)	mm	209 x 108 x 156

Ambient conditions during operation		
temperature	°C	+5 to +40

Spare part sets	Number re-quired	Item (see "4.3 Spare parts set for type KK8 / KV8")
Crankcase cover 0536100001	1	1, 17
Crankshaft with piston	1	On request
Valve plate with lamellar valves 0536100003	1	6, 8, 24
Head Kit 0536100004	1	6, 9, 10, 12, 14, 17, 24
Carbon brushes (12 V) 0536100008	1	-
Sealing cap 0536100010	1	-



## Type D-030E

Electrical data		
Type	D-030E	
Article no.	0826-03	
Electrical frequency	Hz	-
Nominal voltage	V	24 VDC
Rated power	P1 (W)	75
Nominal current	A	3
Speed	min <sup>-1</sup>	1700
Duty cycle		100%
Type of protection (motor)	IP	00

General technical data		
Suction capacity $S_{\text{eff}}$	l/min	30
End pressure $P_{\text{abs}}$	mbar	<180
Noise level	dB(A)	53
Weight	kg	4.4
Dimensions (LxWxH)	mm	209 x 108 x 156

Ambient conditions during operation		
temperature	°C	+5 to +40



Spare part sets	Number re-quired	Item (see "4.3 Spare parts set for type KK8 / KV8")
Crankcase cover 0536100001	1	1, 17
Crankshaft with piston	1	On request
Valve plate with lamellar valves 0536100003	1	6, 8, 24
Head Kit 0536100004	1	6, 9, 10, 12, 14, 17, 24
Carbon brushes (24 V) 0536100009	1	-
Sealing cap 0536100010	1	-



## 5 Oil-free piston compressors and piston vacuum pumps series KK15 / KV15

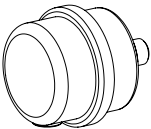
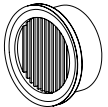
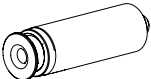
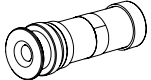
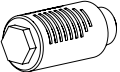

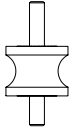
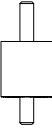
### 5.1 Accessories for piston compressors KK

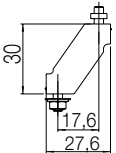
Filter and noise reducer			
	Description	Technical data	Remark
	Air intake filter Standard 0714200015	Special thread for: G1/4" and 1/4" NPT 2 µm filter mesh size	– complete, including air intake filter cartridge
	Air intake filter cartridge Standard 0714200025	2 µm filter mesh size	– Fits air intake filter Standard
	Air intake filter, long 0714200040	G1/4" 3 µm filter mesh size	– complete, including air intake filter cartridge
	Air intake filter cartridge, long 0714200050	3 µm filter mesh size	– Fits air intake filter long
	Air intake filter / noise reducer G1/4" 0714200070	G1/4"	

Vibration damper			
	Description	Technical data	Connector 1/ Connector 2
	Vibration damper set (33 sh) 0536100005	Ø25x20 Hardness: 33 Shore	M6x12/ M6x18
	Vibration damper set (40 sh) 0574100010	Ø25x30 Hardness: 40 Shore	M6x12/ M4x10
	Vibration damper set (40 sh) 1225-991-00	Ø25x20 Hardness: 40 Shore	M6x18/ M6 internal
	Vibration damper set oblique (33 sh) 0832-008-00	Hardness: 40 Shore Fits compressor unit: A-062 / A-062E B-062	M4x10/ M4x10

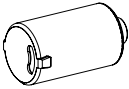
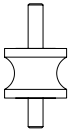
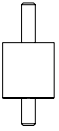

## 5.2 Accessories for piston vacuum pumps KV

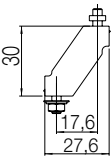
Filter and noise reducer				
	Description		Technical data	Remark
	Air intake filter / noise reducer G1/4"	0714200070	G1/4"	
Vibration damper				
	Description		Technical data	Connector 1/ Connector 2
	Vibration damper set (33 sh)	0536100005	Ø25x20 Hardness: 33 Shore	M6x12/ M6x18
	Vibration damper set (40 sh)	0574100010	Ø25x30 Hardness: 40 Shore	M6x12/ M4x10
	Vibration damper set (40 sh)	1225-991-00	Ø25x20 Hardness: 40 Shore	M6x18/ M6 internal
	Vibration damper set oblique (33 sh)	0832-008-00	Hardness: 40 Shore Fits compressor unit: A-062 / A-062E B-062	M4x10/ M4x10

### 5.3 Spare parts set for type KK15/KV15

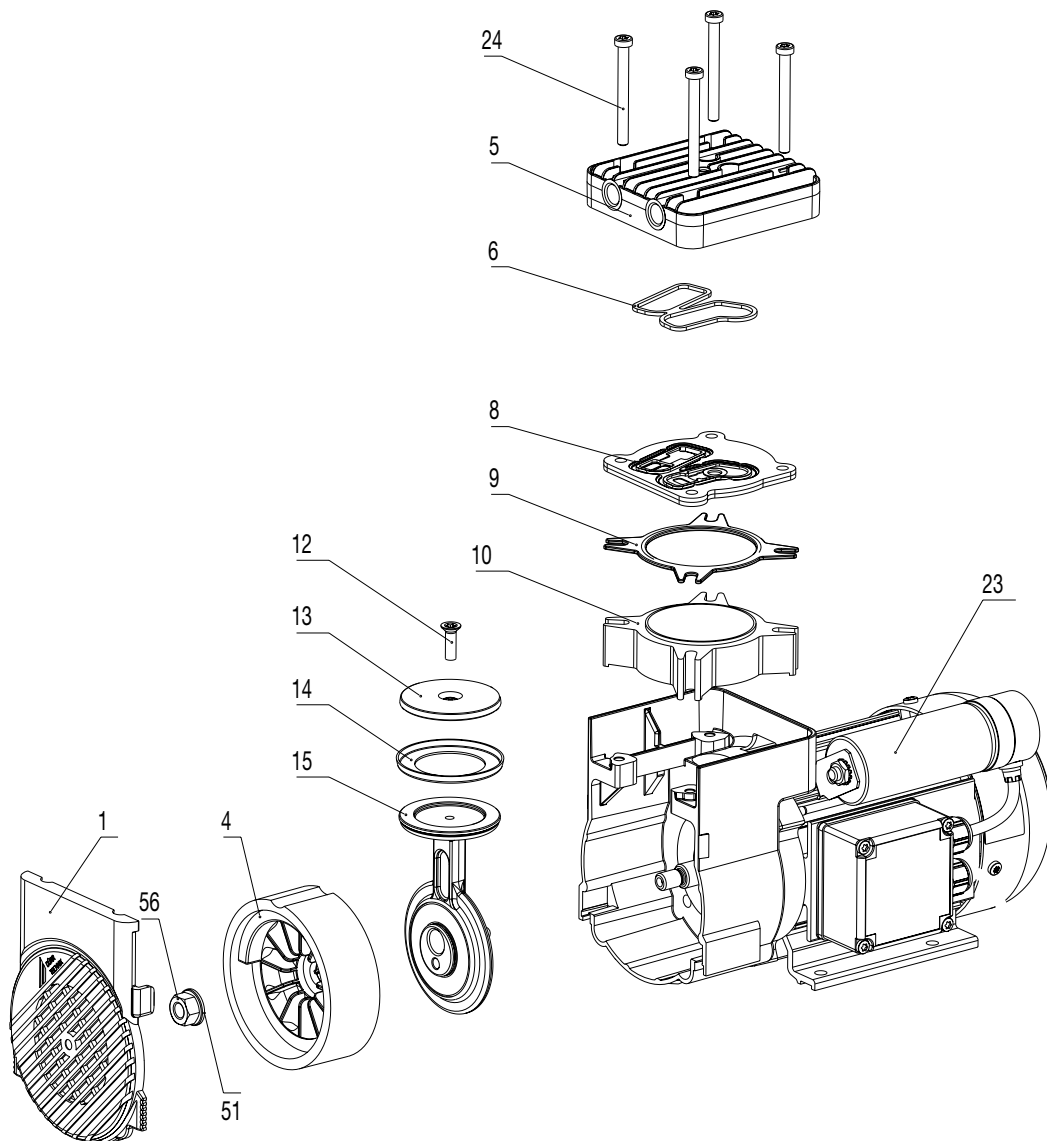

Figure 7: Oil-free piston compressors and piston vacuum pumps KK15/KV15 with item numbers for spare parts

## 5.4 Schematic drawing KK15/KV15

**i** The dimensions (diameter, height) of the vibration dampers are product-specific (refer to the "Accessories – Technical data" section). If different vibration dampers to the ones shown are used then their dimensions will change.

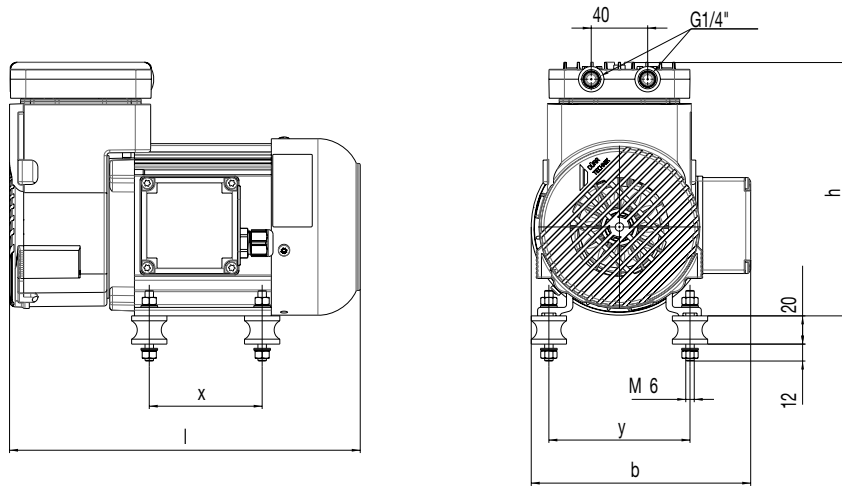

Figure 8: KK15 / KV15, Type: A-038; B-038; A-061; B-061

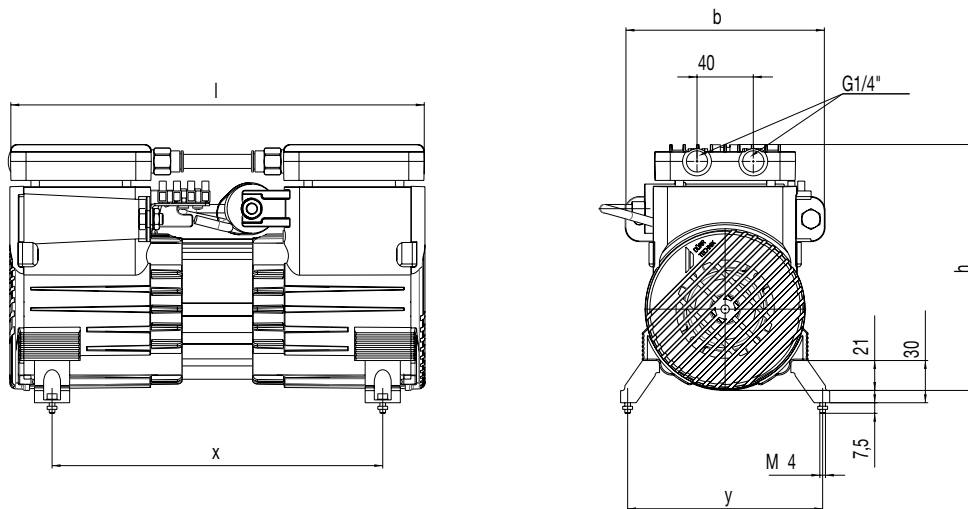

Figure 9: KK15 / KV15; Type: A-062

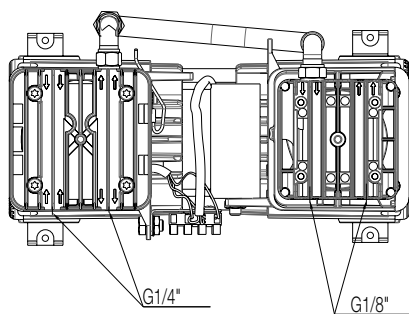

Figure 10: KK15; Type: A-035/62

## 5.5 Performance diagram KK15

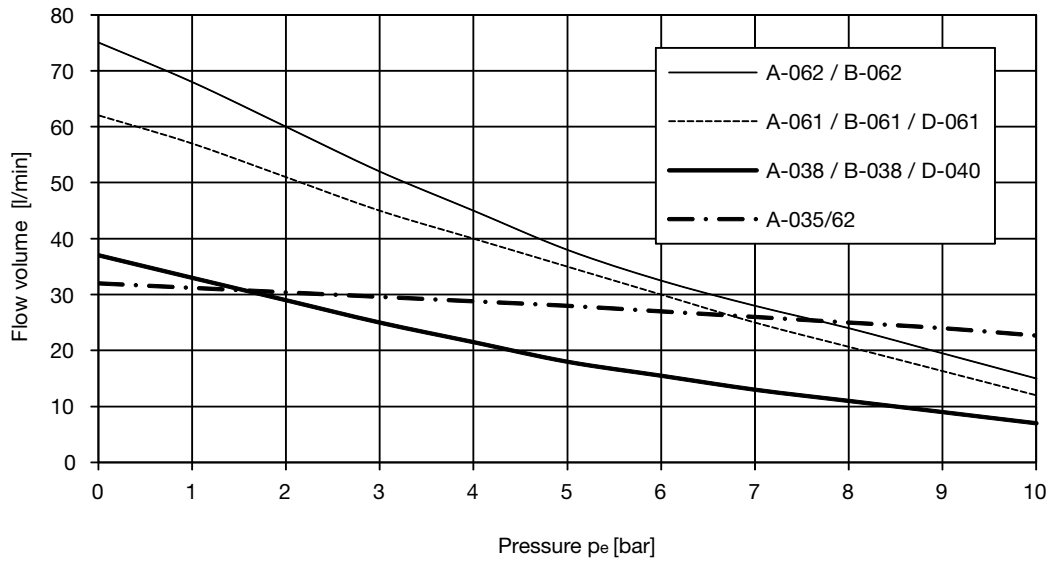

Figure 11: Delivery quantity at 50 Hz (60 Hz approx. +18%)

## 5.6 Performance diagram KV15

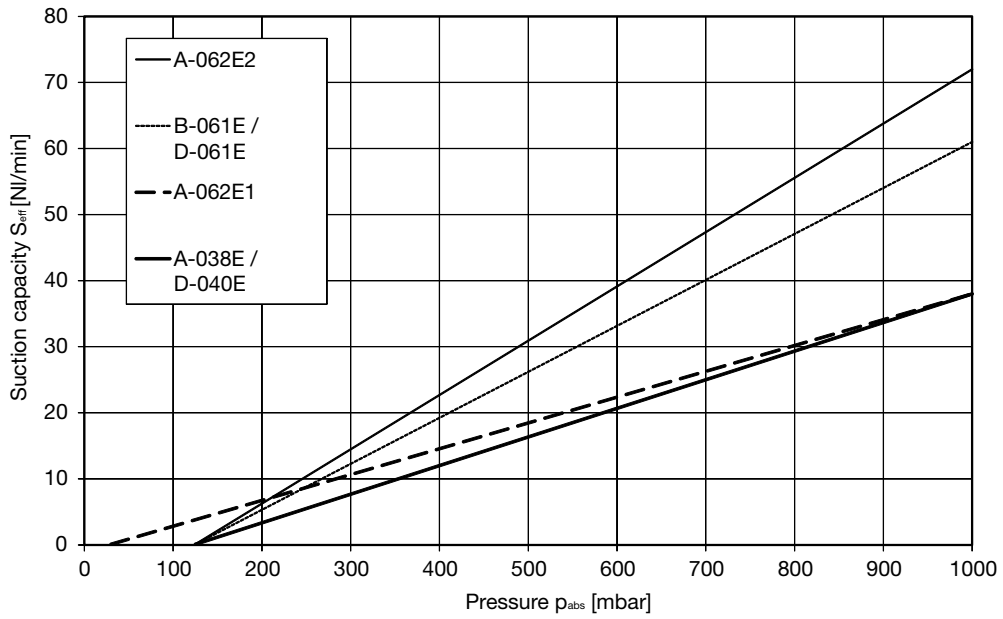

Figure 12: Suction capacity based on atmospheric pressure at 50 Hz (60 Hz approx. +18%)

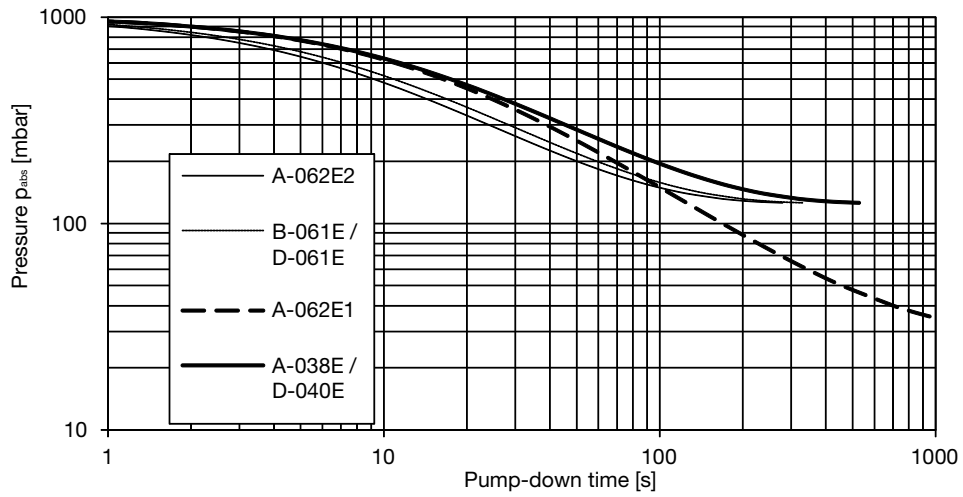

Figure 13: Pump-down time for a 10-l volume at 50 Hz

## 5.7 Technical data for piston compressors KK15

### Type A-035/62

Electrical data			
Type	A-035/62		
Article no.	0841-29		
Electrical frequency	Hz	50	60
Nominal voltage	V	230	230
Rated power	P1 (W)	350	390
Nominal current	A	1.7	1.6
Speed	min <sup>-1</sup>	1385	1650
Duty cycle	%	100	100
Type of protection (motor)	IP	00	00

General technical data			
Delivery quantity 0 bar	l/min	32	32
Nominal pressure	bars	12	12
Safety pressure PS	bars	12	12
Noise level	dB(A)	57	57
Weight	kg	8.5	8.5
Dimensions (LxWxH)	mm	282 x 185 x 205	282 x 185 x 205
Dimensions (x; y)	mm	283; 139	283; 140

Ambient conditions during operation		
temperature	°C	+5 to +40

Spare part sets	Number re-quired	Item (see "5.3 Spare parts set for type KK15/KV15")
Crankcase cover 0574100003	2	1
On request Crankshaft with piston 0574100004	1	On request
On request Valve plate with lamellar valves 0574100006	1	On request
On request Head Kit 0574100007	1	On request

### Type A-038

Electrical data			
Type	A-038		
Article no.	0835-73		
Electrical frequency	Hz	50	60
Nominal voltage	V	230	230
Rated power	P1 (W)	300	340
Nominal current	A	1.5	1.5
Speed	min <sup>-1</sup>	1300	1500
Duty cycle	%	100	100
Type of protection (motor)	IP	54	54

General technical data			
Delivery quantity 0 bar	l/min	38	38
Nominal pressure	bars	7	7
Safety pressure PS	bars	10	10
Noise level	dB(A)	57	59
Weight	kg	6.4	6.4
Dimensions (LxWxH)	mm	249 x 156 x 180	249 x 156 x 180
Dimensions (x; y)	mm	80; 100	80; 100

Ambient conditions during operation		
temperature	°C	+5 to +40

Spare part sets	Number re-quired	Item (see "5.3 Spare parts set for type KK15/KV15")
Crankcase cover 0574100003	1	1
Crankshaft with piston 0574100004	1	4, 6, 9, 10, 12, 13, 14, 15, 51, 56
Valve plate with lamellar valves 0574100006	1	6, 8, 24
Head Kit 0574100007	1	6, 9, 10, 12, 14, 24



## Type A-038

Electrical data			
Type	A-038		
Article no.	0602 1030		
Electrical frequency	Hz	50	60
Nominal voltage	V	230	230
Rated power	P1 (W)	300	340
Nominal current	A	1.5	1.5
Speed	min <sup>-1</sup>	1300	1500
Duty cycle	%	100	100
Type of protection (motor)	IP	54	54

General technical data			
Delivery quantity 0 bar	l/min	38	38
Nominal pressure	bars	7	7
Safety pressure PS	bars	10	10
Noise level	dB(A)	57	59
Weight	kg	6.4	6.4
Dimensions (LxWxH)	mm	249 x 207 x 127	249 x 207 x 127
Dimensions (x; y)	mm	80; 100	80; 100

Ambient conditions during operation		
temperature	°C	+5 to +40

Spare part sets	Number re-quired	Item (see "5.3 Spare parts set for type KK15/KV15")
Crankcase cover 0574100003	1	1
Crankshaft with piston 0574100004	1	4, 6, 9, 10, 12, 13, 14, 15, 51, 56
Valve plate with lamellar valves 0574100006	1	6, 8, 24
Head Kit 0574100007	1	6, 9, 10, 12, 14, 24

## Type A-038

Electrical data			
Type	A-038		
Article no.	0835-49		
Electrical frequency	Hz	50	60
Nominal voltage	V	100-110	100-127
Rated power	P1 (W)	270-300	280-350
Nominal current	A	3.2-3.5	2.8-3.1
Speed	min <sup>-1</sup>	1380	1650-1700
Duty cycle	%	100	100
Type of protection (motor)	IP	44	44

General technical data			
Delivery quantity 0 bar	l/min	38	38
Nominal pressure	bars	7	7
Safety pressure PS	bars	10	10
Noise level	dB(A)	57	59
Weight	kg	9.7	9.7
Dimensions (LxWxH)	mm	258 x 120 x 180	258 x 120 x 180
Dimensions (x; y)	mm	80; 100	80; 100

Ambient conditions during operation		
temperature	°C	+5 to +40

Spare part sets	Number re-quired	Item (see "5.3 Spare parts set for type KK15/KV15")
Crankcase cover 0574100003	1	1
Crankshaft with piston 0574100004	1	4, 6, 9, 10, 12, 13, 14, 15, 51, 56
Valve plate with lamellar valves 0574100006	1	6, 8, 24
Head Kit 0574100007	1	6, 9, 10, 12, 14, 24



## Type A-038

Electrical data			
Type	A-038		
Article no.	0574 1030 (115 V)		
Electrical frequency	Hz	50	60
Nominal voltage	V	115*	115*
Rated power	P1 (W)	310	330
Nominal current	A	4.1	3.2
Speed	min <sup>-1</sup>	1370	1630
Duty cycle	%	100	100
Type of protection (motor)	IP	54	54

General technical data			
Delivery quantity 0 bar	l/min	38	38
Nominal pressure	bars	7	7
Safety pressure PS	bars	10	10
Noise level	dB(A)	57	59
Weight	kg	7.5	7.5
Dimensions (LxWxH)	mm	269 x 156 x 180	269 x 156 x 180
Dimensions (x; y)	mm	80; 100	80; 100

Ambient conditions during operation			
temperature	°C	+5 to +40	

\*Coupling, delivered state

Spare part sets	Number re-quired	Item (see "5.3 Spare parts set for type KK15/KV15")
Crankcase cover 0574100003	1	1
Crankshaft with piston 0574100004	1	4, 6, 9, 10, 12, 13, 14, 15, 51, 56
Valve plate with lamellar valves 0574100006	1	6, 8, 24
Head Kit 0574100007	1	6, 9, 10, 12, 14, 24

## Type A-038

Electrical data			
Type	A-038		
Article no.	0574 1030 (230 V)		
Electrical frequency	Hz	50	60
Nominal voltage	V	230	230
Rated power	P1 (W)	350	410
Nominal current	A	2.1	1.9
Speed	min <sup>-1</sup>	1370	1630
Duty cycle	%	100	100
Type of protection (motor)	IP	54	54

General technical data			
Delivery quantity 0 bar	l/min	38	38
Nominal pressure	bars	7	7
Safety pressure PS	bars	10	10
Noise level	dB(A)	57	59
Weight	kg	7.5	7.5
Dimensions (LxWxH)	mm	269 x 156 x 180	269 x 156 x 180
Dimensions (x; y)	mm	80; 100	80; 100

Ambient conditions during operation			
temperature	°C	+5 to +40	

Spare part sets	Number re-quired	Item (see "5.3 Spare parts set for type KK15/KV15")
Crankcase cover 0574100003	1	1
Crankshaft with piston 0574100004	1	4, 6, 9, 10, 12, 13, 14, 15, 51, 56
Valve plate with lamellar valves 0574100006	1	6, 8, 24
Head Kit 0574100007	1	6, 9, 10, 12, 14, 24



## Type A-038

Electrical data			
Type	A-038		
Article no.	0574 1130 (230 V)		
Electrical frequency	Hz	50	60
Nominal voltage	V	230*	230*
Rated power	P1 (W)	350	410
Nominal current	A	2.1	1.9
Speed	min <sup>-1</sup>	1370	1630
Duty cycle	%	100	100
Type of protection (motor)	IP	54	54

General technical data			
Delivery quantity 0 bar	l/min	38	38
Nominal pressure	bars	7	7
Safety pressure PS	bars	10	10
Noise level	dB(A)	57	59
Weight	kg	7.5	7.5
Dimensions (LxWxH)	mm	269 x 156 x 180	269 x 156 x 180
Dimensions (x; y)	mm	80; 100	80; 100

Ambient conditions during operation		
temperature	°C	+5 to +40

\*Coupling, delivered state

Spare part sets	Number re-quired	Item (see "5.3 Spare parts set for type KK15/KV15")
Crankcase cover 0574100003	1	1
Crankshaft with piston 0574100004	1	4, 6, 9, 10, 12, 13, 14, 15, 51, 56
Valve plate with lamellar valves 0574100006	1	6, 8, 24
Head Kit 0574100007	1	6, 9, 10, 12, 14, 24

## Type A-038

Electrical data			
Type	A-038		
Article no.	0574 1130 (115 V)		
Electrical frequency	Hz	50	60
Nominal voltage	V	115	115
Rated power	P1 (W)	310	330
Nominal current	A	4.1	3.2
Speed	min <sup>-1</sup>	1370	1630
Duty cycle	%	100	100
Type of protection (motor)	IP	54	54

General technical data			
Delivery quantity 0 bar	l/min	38	38
Nominal pressure	bars	7	7
Safety pressure PS	bars	10	10
Noise level	dB(A)	57	59
Weight	kg	7.5	7.5
Dimensions (LxWxH)	mm	269 x 156 x 180	269 x 156 x 180
Dimensions (x; y)	mm	80; 100	80; 100

Ambient conditions during operation		
temperature	°C	+5 to +40

Spare part sets	Number re-quired	Item (see "5.3 Spare parts set for type KK15/KV15")
Crankcase cover 0574100003	1	1
Crankshaft with piston 0574100004	1	4, 6, 9, 10, 12, 13, 14, 15, 51, 56
Valve plate with lamellar valves 0574100006	1	6, 8, 24
Head Kit 0574100007	1	6, 9, 10, 12, 14, 24

**Type B-038**

Electrical data			
Type	B-038		
Article no.	0835-75..		
Electrical frequency	Hz	50	60
Nominal voltage	V	3 ph. 400	3 ph. 400
Rated power	P1 (W)	410	370
Nominal current	A	0.9	0.8
Speed	min <sup>-1</sup>	1400	1670
Duty cycle	%	100	100
Type of protection (motor)	IP	54	54

General technical data			
Delivery quantity 0 bar	l/min	38	38
Nominal pressure	bars	7	7
Safety pressure PS	bars	10	10
Noise level	dB(A)	57	59
Weight	kg	6.5	6.5
Dimensions (LxWxH)	mm	249 x 156 x 180	249 x 156 x 180
Dimensions (x; y)	mm	80; 100	80; 100

Ambient conditions during operation		
temperature	°C	+5 to +40

Spare part sets	Number re-quired	Item (see "5.3 Spare parts set for type KK15/KV15")
Crankcase cover 0574100003	1	1
Crankshaft with piston 0574100004	1	4, 6, 9, 10, 12, 13, 14, 15, 51, 56
Valve plate with lamellar valves 0574100006	1	6, 8, 24
Head Kit 0574100007	1	6, 9, 10, 12, 14, 24

**Type D-040**

Electrical data		
Type	B-040	
Article no.	0832-25	
Electrical frequency	Hz	-
Nominal voltage	V	12 VDC
Rated power	P1 (W)	192
Nominal current	A	17.5
Speed	min <sup>-1</sup>	1600
Duty cycle	%	100
Type of protection	IP	00

General technical data		
Delivery quantity 0 bar	l/min	40
Nominal pressure	bars	7
Safety pressure PS	bars	10
Noise level	dB(A)	61
Weight	kg	5.9
Dimensions (LxWxH)	mm	242 x 121 x 175
Dimensions (x; y)	mm	155; 92/139
Remarks		

Ambient conditions during operation		
temperature	°C	+5 to +40

Spare part sets	Number re-quired	Item (see "5.3 Spare parts set for type KK15/KV15")
Crankcase cover 0574100003	1	1
Crankshaft with piston 0574100005	1	4, 6, 9, 10, 12, 13, 14, 15, 51, 56
Valve plate with lamellar valves 0574100006	1	6, 8, 24
Head Kit 0574100007	1	6, 9, 10, 12, 14, 24
Carbon brushes (12 V) 0536100008	1	-
Sealing cap 0536100010	1	-
Relay (12 V) 0574100017	1	-



## Type D-040

Electrical data		
Type	D-040	
Article no.	0832-22..	
Electrical frequency	Hz	-
Nominal voltage	V	24 VDC
Rated power	P1 (W)	192
Nominal current	A	9
Speed	min <sup>-1</sup>	1800
Duty cycle	%	100
Type of protection (motor)	IP	00

General technical data		
Delivery quantity 0 bar	l/min	40
Nominal pressure	bars	7
Safety pressure PS	bars	10
Noise level	dB(A)	61
Weight	kg	5.9
Dimensions (LxWxH)	mm	242 x 121 x 175
Dimensions (x; y)	mm	155; 92/139

Ambient conditions during operation		
temperature	°C	+5 to +40

Spare part sets	Number re-quired	Item (see "5.3 Spare parts set for type KK15/KV15")
Crankcase cover 0574100003	1	1
Crankshaft with piston 0574100005	1	4, 6, 9, 10, 12, 13, 14, 15, 51, 56
Valve plate with lamellar valves 0574100006	1	6, 8, 24
Head Kit 0574100007	1	6, 9, 10, 12, 14, 24
Carbon brushes (24 V) 0536100009	1	-
Sealing cap 0536100010	1	-
Relay 24 V 0536100016	1	-
Interference suppression filter with wiring harness 0832-990-50	1	-

## Type A-061

Electrical data			
Type	A-061		
Article no.	0835-74..		
Electrical frequency	Hz	50	60
Nominal voltage	V	230	230
Rated power	P1 (W)	540	610
Nominal current	A	2.9	2.7
Speed	min <sup>-1</sup>	2680	3130
Duty cycle	%	100	100
Type of protection (motor)	IP	54	54

General technical data			
Delivery quantity 0 bar	l/min	60	60
Nominal pressure	bars	7	7
Safety pressure PS	bars	10	10
Noise level	dB(A)	66	68
Weight	kg	7.6	7.6
Dimensions (LxWxH)	mm	269 x 156 x 180	269 x 156 x 180
Dimensions (x; y)	mm	80; 100	80; 100

Ambient conditions during operation		
temperature	°C	+5 to +40

Spare part sets	Number re-quired	Item (see "5.3 Spare parts set for type KK15/KV15")
Crankcase cover 0574100003	1	1
Crankshaft with piston 0574100004	1	4, 6, 9, 10, 12, 13, 14, 15, 51, 56
Valve plate with lamellar valves 0574100006	1	6, 8, 24
Head Kit 0574100007	1	6, 9, 10, 12, 14, 24

## Type B-061

Electrical data			
Type	B-061		
Article no.	0575 1000		
Electrical frequency	Hz	50	60
Nominal voltage	V	3-ph. 400	3-ph. 400
Rated power	P1 (W)	500	500
Nominal current	A	0.9	0.9
Speed	min <sup>-1</sup>	2740	3200
Duty cycle	%	100	100
Type of protection (motor)	IP	54	54

General technical data			
Delivery quantity 0 bar	l/min	60	60
Nominal pressure	bars	7	7
Safety pressure PS	bars	10	10
Noise level	dB(A)	66	66
Weight	kg	6.1	6.1
Dimensions (LxWxH)	mm	225 x 165 x 180	225 x 165 x 180
Dimensions (x; y)	mm	80; 100	80; 100

Ambient conditions during operation		
temperature	°C	+5 to +40

Spare part sets	Number re-quired	Item (see "5.3 Spare parts set for type KK15/KV15")
Crankcase cover 0574100003	1	1
Crankshaft with piston 0574100004	1	4, 6, 9, 10, 12, 13, 14, 15, 51, 56
Valve plate with lamellar valves 0574100006	1	6, 8, 24
Head Kit 0574100007	1	6, 9, 10, 12, 14, 24

## Type D-061

Electrical data		
Type	D-061	
Article no.	0361 1000	
Electrical frequency	Hz	-
Nominal voltage	V	110 VDC
Rated power	P1 (W)	400
Nominal current	A	3.7
Speed	min <sup>-1</sup>	2610
Duty cycle	%	S3 30 min. 50%
Type of protection (motor)	IP	54

General technical data		
Delivery quantity 0 bar	l/min	60
Nominal pressure	bars	7
Safety pressure PS	bars	10
Noise level	dB(A)	69
Weight	kg	6.9
Dimensions (LxWxH)	mm	247 x 132 x 188
Dimensions (x; y)	mm	90; 112

Ambient conditions during operation		
temperature	°C	-25 to +50

Spare part sets	Number re-quired	Item (see "5.3 Spare parts set for type KK15/KV15")
Crankcase cover 0574100003	1	1
Crankshaft with piston 0574100004	1	4, 6, 9, 10, 12, 13, 14, 15, 51, 56
Valve plate with lamellar valves 0574100006	1	6, 8, 24
Head Kit 0574100007	1	6, 9, 10, 12, 14, 24
Carbon brushes (24 V motor) 0574100023	1	-



## Type D-061

Electrical data		
Type	D-061	
Article no.	0513 1000	
Electrical frequency	Hz	-
Nominal voltage	V	24 VDC
Rated power	P1 (W)	500
Nominal current	A	21
Speed	min <sup>-1</sup>	2900
Duty cycle	%	100
Type of protection (motor)	IP	54

General technical data		
Delivery quantity 0 bar	l/min	60
Nominal pressure	bars	7
Safety pressure PS	bars	10
Noise level	dB(A)	69
Weight	kg	6.9
Dimensions (LxWxH)	mm	247 x 132 x 188
Dimensions (x; y)	mm	90; 112
Remarks		

Ambient conditions during operation		
temperature	°C	-40 to +40

Spare part sets	Number re-quired	Item (see "5.3 Spare parts set for type KK15/KV15")
Crankcase cover 0574100003	1	1
Crankshaft with piston 0574100004	1	4, 6, 9, 10, 12, 13, 14, 15, 51, 56
Valve plate with lamellar valves 0574100006	1	6, 8, 24
Head Kit 0574100007	1	6, 9, 10, 12, 14, 24
Carbon brushes (24 V motor) 0574100023	1	-

## Type D-061

Electrical data		
Type	D-061	
Article no.	0835-46	
Electrical frequency	Hz	-
Nominal voltage	V	12 VDC
Rated power	P1 (W)	520
Nominal current	A	43
Speed	min <sup>-1</sup>	2400
Duty cycle	%	S3 10 min. 50%
Type of protection (motor)	IP	54

General technical data		
Delivery quantity 0 bar	l/min	60
Nominal pressure	bars	7
Safety pressure PS	bars	10
Noise level	dB(A)	69
Weight	kg	7.2
Dimensions (LxWxH)	mm	234 x 132 x 188
Dimensions (x; y)	mm	90; 112

Ambient conditions during operation		
temperature	°C	+5 to +40

Spare part sets	Number re-quired	Item (see "5.3 Spare parts set for type KK15/KV15")
Crankcase cover 0574100003	1	1
Crankshaft with piston 0574100004	1	4, 6, 9, 10, 12, 13, 14, 15, 51, 56
Valve plate with lamellar valves 0574100006	1	6, 8, 24
Head Kit 0574100007	1	6, 9, 10, 12, 14, 24
Carbon brushes (24 V motor) 0574100023	1	-

## Type A-062

Electrical data		
Type	A-062	
Article no.	0834-23..	
Electrical frequency	Hz	50
Nominal voltage	V	230
Rated power	P1 (W)	435
Nominal current	A	2
Speed	min <sup>-1</sup>	1390
Duty cycle	%	100
Type of protection (motor)	IP	00 / 20*

General technical data		
Delivery quantity 0 bar	l/min	78
Nominal pressure	bars	7
Safety pressure PS	bars	10
Noise level	dB(A)	59
Weight	kg	9.8
Dimensions (LxWxH)	mm	298 x 125 x 175
Dimensions (x; y)	mm	225; 139
Remarks		

Ambient conditions during operation		
temperature	°C	+5 to +40

\*If a terminal box is fitted, the electrical components are covered. The IP rating is then IP20.

Spare part sets	Number re-quired	Item (see "5.3 Spare parts set for type KK15/KV15")
Crankcase cover 0574100003	2	1
Crankshaft with piston 0574100004	2	4, 6, 9, 10, 12, 13, 14, 15, 51, 56
Valve plate with lamellar valves 0574100006	2	6, 8, 24
Head Kit 0574100007	2	6, 9, 10, 12, 14, 24

## Type A-062

Electrical data		
Type	A-062	
Article no.	0834-27	
Electrical frequency	Hz	60
Nominal voltage	V	230
Rated power	P1 (W)	550
Nominal current	A	2.4
Speed	min <sup>-1</sup>	1660
Duty cycle	%	100
Type of protection (motor)	IP	00 / 20*

General technical data		
Delivery quantity 0 bar	l/min	75
Nominal pressure	bars	7
Safety pressure PS	bars	10
Noise level	dB(A)	60
Weight	kg	10
Dimensions (LxWxH)	mm	298 x 125 x 175
Dimensions (x; y)	mm	225; 139

Ambient conditions during operation		
temperature	°C	+5 to +40

\*If a terminal box is fitted, the electrical components are covered. The IP rating is then IP20.

Spare part sets	Number re-quired	Item (see "5.3 Spare parts set for type KK15/KV15")
Crankcase cover 0574100003	2	1
Crankshaft with piston 0574100004	2	4, 6, 9, 10, 12, 13, 14, 15, 51, 56
Valve plate with lamellar valves 0574100006	2	6, 8, 24
Head Kit 0574100007	2	6, 9, 10, 12, 14, 24



## Type A-062

Electrical data		
Type	A-062	
Article no.	0833-36	
Electrical frequency	Hz	60
Nominal voltage	V	115
Rated power	P1 (W)	530
Nominal current	A	5.3
Speed	min <sup>-1</sup>	1620
Duty cycle	%	100
Type of protection (motor)	IP	00

General technical data		
Delivery quantity 0 bar	l/min	75
Nominal pressure	bars	7
Safety pressure PS	bars	10
Noise level	dB(A)	60
Weight	kg	10
Dimensions (LxWxH)	mm	283 x 125 x 175
Dimensions (x; y)	mm	225; 139

Ambient conditions during operation		
temperature	°C	+5 to +40

\*If a terminal box is fitted, the electrical components are covered. The IP rating is then IP20.

Spare part sets	Number re-quired	Item (see "5.3 Spare parts set for type KK15/KV15")
Crankcase cover 0574100003	2	1
Crankshaft with piston 0574100005	2	4, 6, 9, 10, 12, 13, 14, 15, 51, 56
Valve plate with lamellar valves 0574100006	2	6, 8, 24
Head Kit 0574100007	2	6, 9, 10, 12, 14, 24

## Type B-062

Electrical data			
Type	B-062		
Article no.	0834-13		
Electrical frequency	Hz	50	60
Nominal voltage	V	3-ph. 380-415	3-ph. 460-500
Rated power	P1 (W)	470	570
Nominal current	A	0.9	0.9
Speed	min <sup>-1</sup>	1315	1635
Duty cycle	%	100	100
Type of protection (motor)	IP	20	20

General technical data			
Delivery quantity 0 bar	l/min	78	78
Nominal pressure	bars	8.5	8.5
Safety pressure PS	bars	10	10
Noise level	dB(A)	60	60
Weight	kg	9.1	9.1
Dimensions (LxWxH)	mm	286 x 125 x 175	286 x 125 x 175
Dimensions (x; y)	mm	218; 139	218; 139

Ambient conditions during operation		
temperature	°C	+5 to +40

Spare part sets	Number re-quired	Item (see "5.3 Spare parts set for type KK15/KV15")
Crankcase cover 0574100003	2	1
Crankshaft with piston 0574100004	2	4, 6, 9, 10, 12, 13, 14, 15, 51, 56
Valve plate with lamellar valves 0574100006	2	6, 8, 24
Head Kit 0574100007	2	6, 9, 10, 12, 14, 24



## 5.8 Technical data for piston vacuum pumps KV15

### Typ A-038E

Electrical data			
Type	A-038E		
Article no.	0839-73		
Electrical frequency	Hz	50	60
Nominal voltage	V	230	230
Rated power	P1 (W)	200	220
Nominal current	A	1.3	1
Speed	min <sup>-1</sup>	1445	1710
Duty cycle		100%	100%
Type of protection (motor)	IP	54	54

General technical data			
Suction capacity $S_{eff}$	l/min	38	38
End pressure $P_{abs}$	mbar	150	150
Noise level	dB(A)	54	56
Weight	kg	6.4	6.4
Dimensions (LxWxH)	mm	249 x 156 x 180	249 x 156 x 180
Dimensions (x; y)		80; 100	80; 100

Ambient temperature during operation		
temperature	°C	+5 to +40

Spare part sets	Number re-quired	Item (see "5.3 Spare parts set for type KK15/KV15")
Crankcase cover 0574100003	1	1, 17
Crankshaft with piston	1	On request
Valve plate with lamellar valves 0574100006	1	6, 8, 24
Head Kit 0574100007	1	6, 9, 10, 12, 14, 24

### Type D-040E

Electrical data		
Type	D-040E (12V)	
Article no.	0839-25	
Electrical frequency	Hz	-
Nominal voltage	V	12 VDC
Rated power	P1 (W)	104
Nominal current	A	8.7
Speed	min <sup>-1</sup>	1800
Duty cycle	%	100
Type of protection (motor)	IP	20

General technical data		
Suction capacity $S_{eff}$	l/min	40
End pressure $P_{abs}$	mbar	150
Noise level	dB(A)	59
Weight	kg	6
Dimensions (LxWxH)	mm	242 x 121 x 175
Dimensions (x; y)		155; 92/139

Ambient temperature during operation		
temperature	°C	+5 to +40

Spare part sets	Number re-quired	Item (see "5.3 Spare parts set for type KK15/KV15")
Crankcase cover 0574100003	1	1, 17
Crankshaft with piston	1	On request
Valve plate with lamellar valves 0574100006	1	6, 8, 24
Head Kit 0574100007	1	6, 9, 10, 12, 14, 24
Carbon brushes (12 V) 0536100008	1	-
Sealing cap 0536100010	1	-
Relay (12 V) 0574100017	1	-



## Type D-040E

Electrical data		
Type	D-040E (24V)	
Article no.	0839-22	
Electrical frequency	Hz	-
Nominal voltage	V	24 VDC
Rated power	P1 (W)	120
Nominal current	A	5
Speed	min <sup>-1</sup>	2000
Duty cycle	%	100
Type of protection (motor)	IP	20

General technical data		
Suction capacity S <sub>eff</sub>	l/min	40
End pressure P <sub>abs</sub>	mbar	150
Noise level	dB(A)	59
Weight	kg	6
Dimensions (LxWxH)	mm	242 x 121 x 175
Dimensions (x; y)		155; 92/139

Ambient temperature during operation		
temperature	°C	+5 to +40

Spare part sets	Number re-quired	Item (see "5.3 Spare parts set for type KK15/KV15")
Crankcase cover 0574100003	1	1, 17
Crankshaft with piston	1	On request
Valve plate with lamellar valves 0574100006	1	6, 8, 24
Head Kit 0574100007	1	6, 9, 10, 12, 14, 24
Carbon brushes (24 V) 0536100009	1	-
Sealing cap 0536100010	1	-
Relay 24 V 0536100016	1	-
Interference suppression filter with wiring harness 0832-990-50	1	-

## Type B-061E

Electrical data			
Type	B-061E		
Article no.	0575 1100		
Electrical frequency	Hz	50	60
Nominal voltage	V	3-ph. 400	3-ph. 400
Rated power	P1 (W)	500	500
Nominal current	A	0.9	0.9
Speed	min <sup>-1</sup>	2740	3200
Duty cycle	%	100	100
Type of protection (motor)	IP	54	54

General technical data			
Suction capacity S <sub>eff</sub>	l/min	61	61
End pressure P <sub>abs</sub>	mbar	150	150
Noise level	dB(A)	61	63
Weight	kg	6.1	6.1
Dimensions (LxWxH)	mm	225 x 165 x 180	225 x 165 x 180
Dimensions (x; y)		80; 100	80; 100

Ambient temperature during operation		
temperature	°C	+5 to +40

Spare part sets	Number re-quired	Item (see "5.3 Spare parts set for type KK15/KV15")
Crankcase cover 0574100003	1	1, 17
Crankshaft with piston	1	On request
Valve plate with lamellar valves 0574100006	1	6, 8, 24
Head Kit 0574100007	1	6, 9, 10, 12, 14, 24

## Type D-061E (24V)

Electrical data		
Type	D-061E (24V)	
Article no.	0513 1100	
Electrical frequency	Hz	-
Nominal voltage	V	24 VDC
Rated power	P1 (W)	264
Nominal current	A	11
Speed	min <sup>-1</sup>	2950
Duty cycle	%	100
Type of protection (motor)	IP	54

General technical data		
Suction capacity $S_{\text{eff}}$	l/min	61
End pressure $P_{\text{abs}}$	mbar	150
Noise level	dB(A)	61
Weight	kg	7.1
Dimensions (LxWxH)	mm	234 x 137 x 190
Dimensions (x; y)		90; 112

Ambient temperature during operation		
temperature	°C	+5 to +40

Spare part sets	Number re-quired	Item (see "5.3 Spare parts set for type KK15/KV15")
Crankcase cover 0574100003	1	1, 17
Crankshaft with piston	1	On request
Valve plate with lamellar valves 0574100006	1	6, 8, 24
Head Kit 0574100007	1	6, 9, 10, 12, 14, 24

## Type A-062E2

Electrical data			
Type	A-062E2		
Article no.	0838-21A		
Electrical frequency	Hz	50	60
Nominal voltage	V	230	230
Rated power		260	340
P1 (W)			
Nominal current	A	1.2	1.7
Speed	min <sup>-1</sup>	1360	1620
Duty cycle	%	100	100
Type of protection (motor)	IP	20	20

General technical data			
Suction capacity $S_{\text{eff}}$	l/min	72	72
End pressure $P_{\text{abs}}$	mbar	150	150
Noise level	dB(A)	53	55
Weight	kg	9.3	9.3
Dimensions (LxWxH)	mm	291 x 150 x 183	291 x 150 x 183
Dimensions (x; y)		225; 139	225; 139

Ambient temperature during operation		
temperature	°C	+5 to +40

Spare part sets	Number re-quired	Item (see "5.3 Spare parts set for type KK15/KV15")
Crankcase cover 0574100003	2	1
Crankshaft with piston	2	On request
Valve plate with lamellar valves 0574100006	2	6, 8, 24
Head Kit 0574100007	2	6, 9, 10, 12, 14, 24

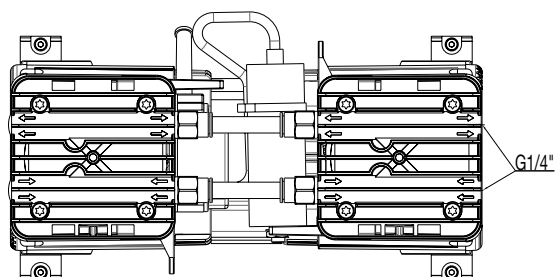

Figure 14: KV15; Type: A-062E2

Type A-062E1

Electrical data			
Type	A-062E1		
Article no.	0837-21A		
Electrical frequency	Hz	50	60
Nominal voltage	V	230	230
Rated power	P1 (W)	250	260
Nominal current	A	1.6	1.2
Speed	min <sup>-1</sup>	1410	1630
Duty cycle	%	100	100
Type of protection (motor)	IP	20	20

General technical data			
Suction capacity $S_{eff}$	l/min	38	38
End pressure $P_{abs}$	mbar	30	30
Noise level	dB(A)	49	51
Weight	kg	9.3	9.3
Dimensions (LxWxH)	mm	291 x 139 x 205	291 x 139 x 205
Dimensions (x; y)		225; 139	225; 139

Ambient temperature during operation		
temperature	°C	+5 to +40

Spare part sets	Number required	Item (see "5.3 Spare parts set for type KK15/KV15")
Crankcase cover 0574100003	2	1
Crankshaft with piston	2	On request
Valve plate with lamellar valves 0574100006	2	6, 8, 24
Head Kit 0574100007	2	6, 9, 10, 12, 14, 24

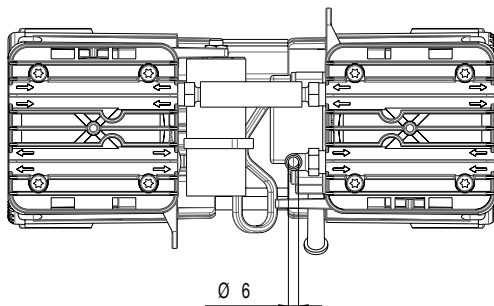
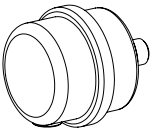
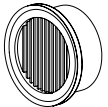
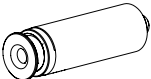
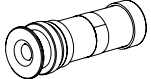
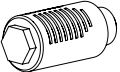
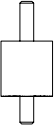
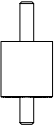



Figure 15: KV15; Type: A-062E1

## 6 Oil-free piston compressors and piston vacuum pumps series KK40 / KV40



### 6.1 Accessories for piston compressors KK

Filter and noise reducer			
	Description	Technical data	Remark
	Air intake filter Standard	0714200015 Special thread for: G1/4" and 1/4" NPT 2 µm filter mesh size	– complete, including air intake filter cartridge
	Air intake filter cartridge Standard	0714200025 2 µm filter mesh size	– Fits air intake filter Standard
	Air intake filter, long	0714200040 G1/4" 3 µm filter mesh size	– complete, including air intake filter cartridge
	Air intake filter cartridge, long	0714200050 3 µm filter mesh size	– Fits air intake filter long
	Air intake filter / noise reducer G1/4"	0714200070 G1/4"	

Vibration damper			
	Description	Technical data	Connector 1/ Connector 2
	Vibration damper set	0880100018 Ø30x32 Hardness: 34 Shore	M8x16/ M8x22
	Vibration damper set	0881-991-00 Ø40x40 Hardness: 40 Shore	M8x15/ M8x23
	Vibration damper set (40 sh)	1225-991-00 Ø25x20 Hardness: 40 Shore	M6x18/ M6 internal

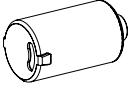
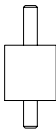

## 6.2 Accessories for piston vacuum pumps KV

Filter and noise reducer				
	Description		Technical data	Remark
	Air intake filter / noise reducer G1/4"	0714200070	G1/4"	
Vibration damper				
	Description		Technical data	Connector 1/ Connector 2
	Vibration damper set	0880100018	Ø30x32 Hardness: 34 Shore	M8x16/ M8x22
	Vibration damper set	0881-991-00	Ø40x40 Hardness: 40 Shore	M8x15/ M8x23
	Vibration damper set (40 sh)	1225-991-00	Ø25x20 Hardness: 40 Shore	M6x18/ M6 internal

### 6.3 Schematic drawing KK40 / KV40

 The dimensions (diameter, height) of the vibration dampers are product-specific (refer to the "Accessories – Technical data" section). If different vibration dampers to the ones shown are used then their dimensions will change.

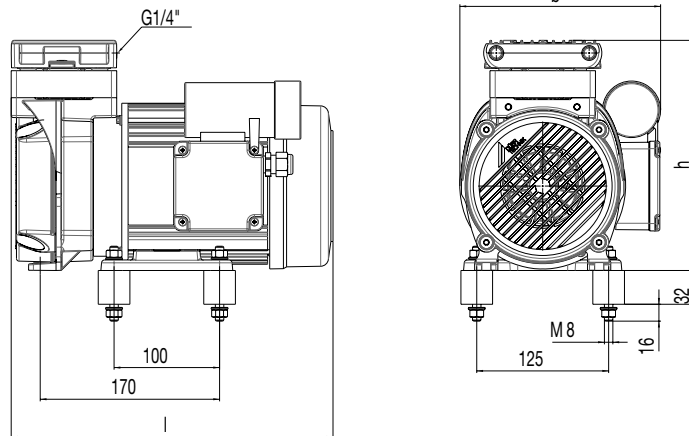

Figure 16: KK40 / KV40; Type: A-065; B-065; A-065E

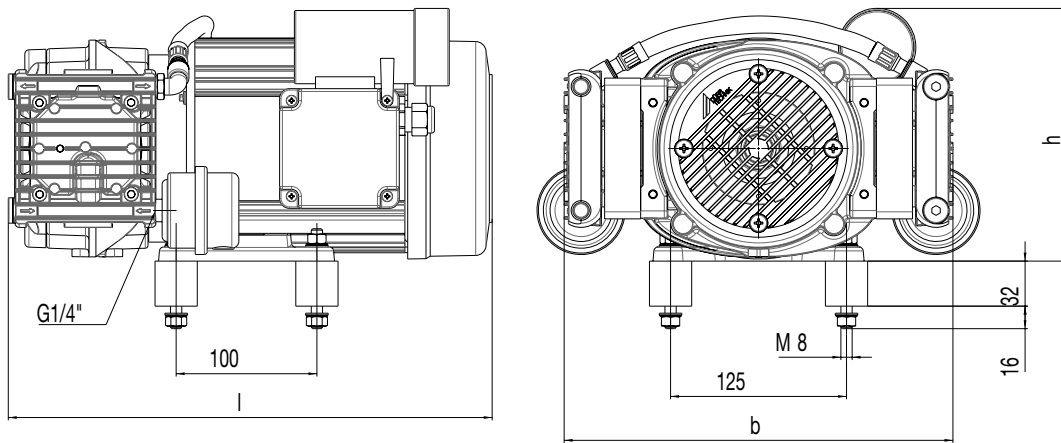

Figure 17: KK40 / KV40; Type: AG-132; BG-132; AG-065-2E; A-065E; AG-132E; BG-132E

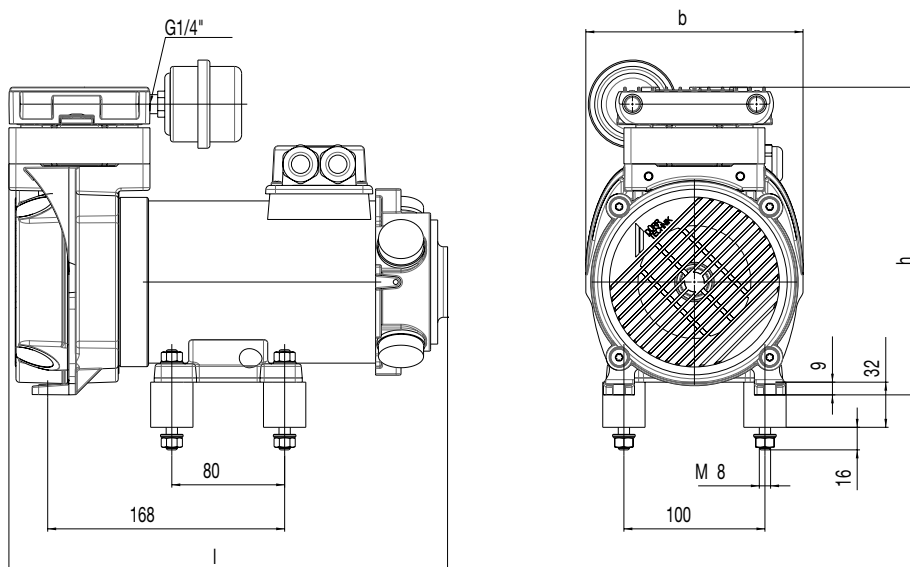

Figure 18: KK40 / KV40; Type: D-075



EN

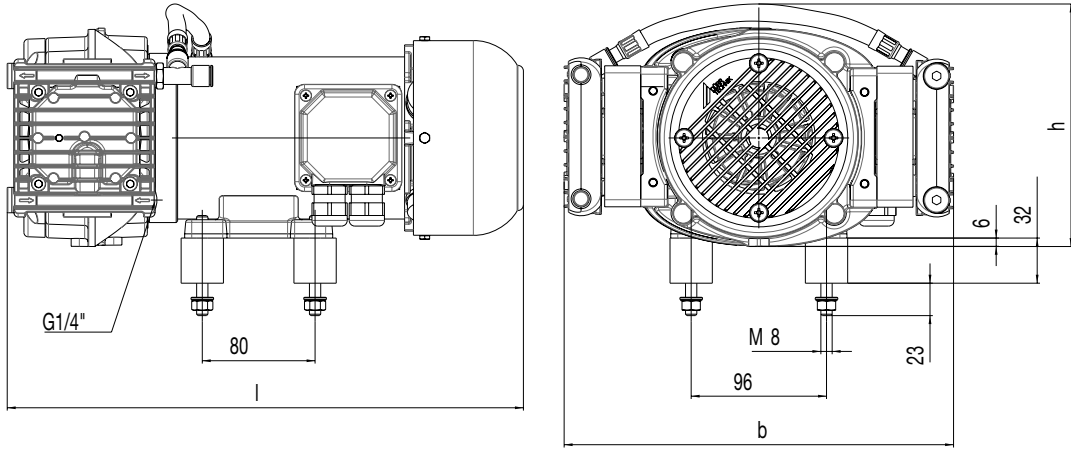

Figure 19: KK40; Type: DG-160



## 6.4 Spare parts set for type KK40 / KV40

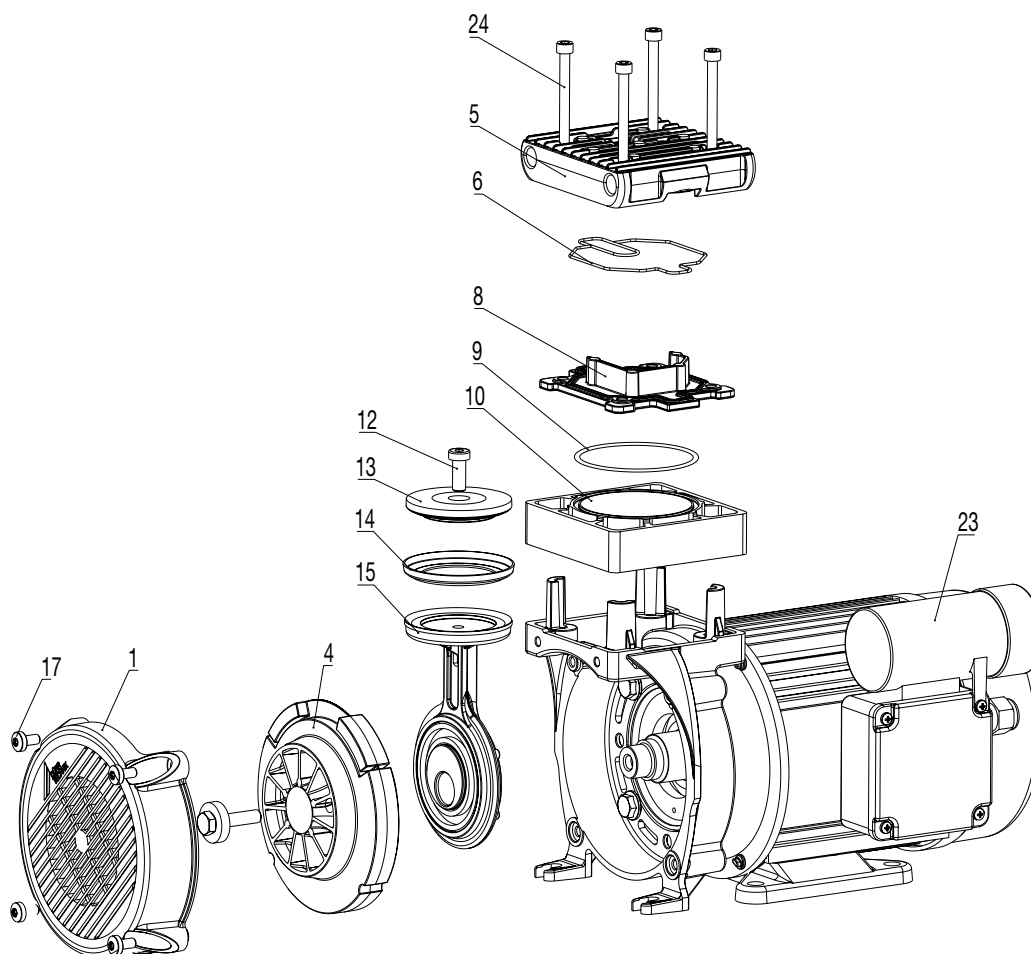

Figure 20: Oil-free piston compressors and piston vacuum pumps KK40 / KV40 with item numbers for spare parts



### 6.5 Performance diagram KK40

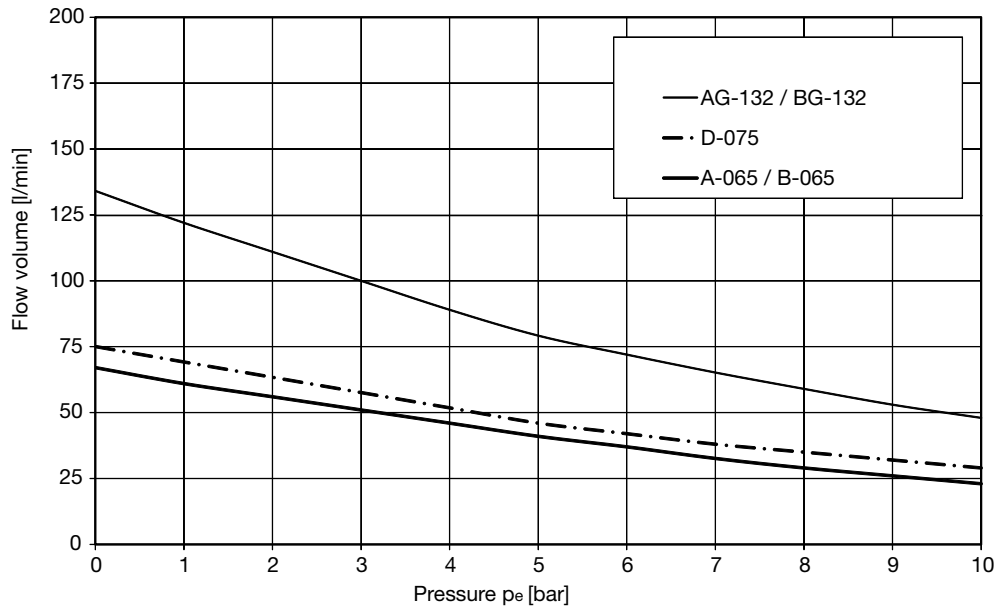

Figure 21: Delivery quantity at 50 Hz (60 Hz approx. +18%)

### 6.6 Performance diagram KV40

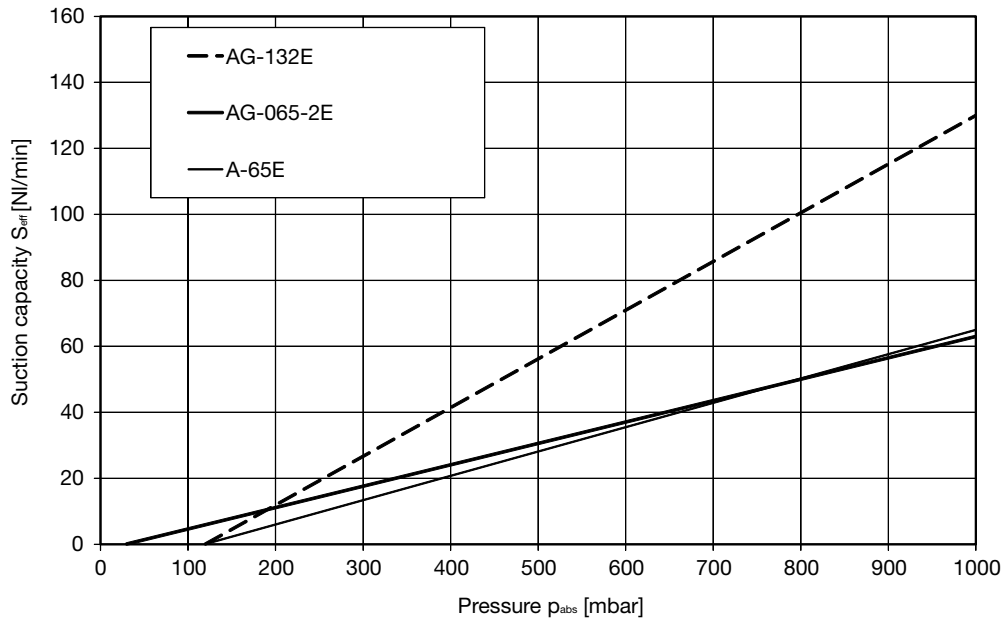

Figure 22: Suction capacity based on atmospheric pressure at 50 Hz (60 Hz approx. +18%)

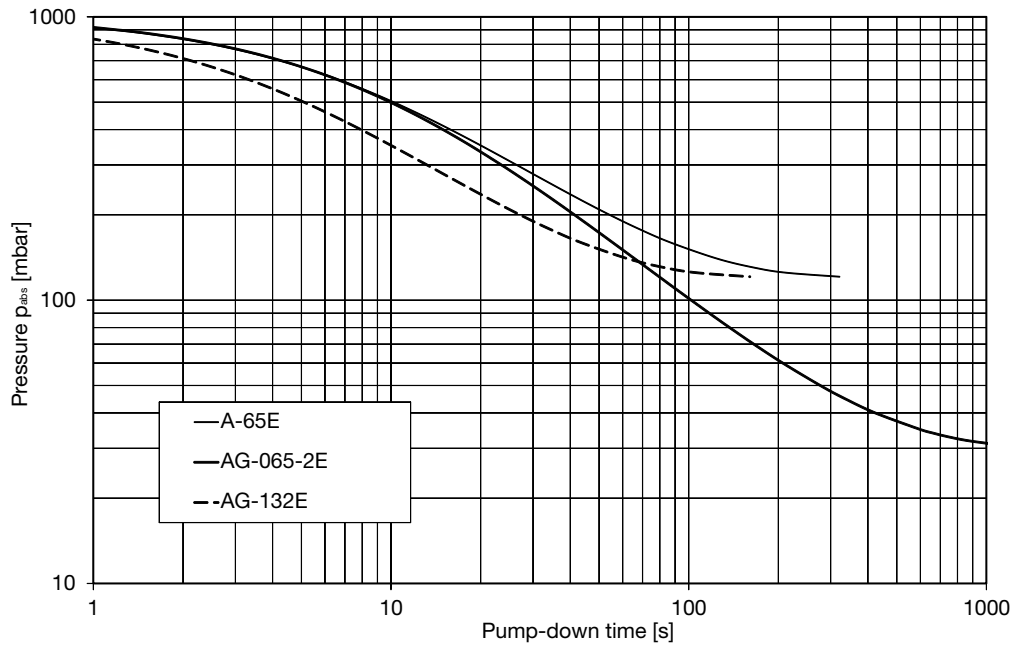

Figure 23: Pump-down time for a 10-l volume at 50 Hz



## 6.7 Technical data for piston compressors KK40

### Type A-065

Electrical data			
Type	A-065		
Article no.	0431 1100		
Electrical frequency	Hz	50	60
Nominal voltage	V	230	230
Rated power	P1 (W)	530	590
Nominal current	A	2.5	2.6
Speed	min <sup>-1</sup>	1350	1600
Duty cycle	%	100	100
Type of protection (motor)	IP	54	54

General technical data			
Delivery quantity 0 bar	l/min	65	65
Nominal pressure	bars	7	7
Safety pressure PS	bars	10	10
Noise level	dB(A)	68	70
Weight	kg	14.4	14.4
Dimensions (LxWxH)	mm	305 x 195 x 218	305 x 195 x 218

Ambient conditions during operation		
temperature	°C	-30 to +55

Spare part sets	Number re-quired	Item (see "6.4 Spare parts set for type KK40 / KV40")
Crankcase cover 0431100008	1	1, 17
Valve plate with lamellar valves 0431100009	1	6, 8, 24
Head Kit 0431100011	1	6, 9, 10, 12, 14, 17, 24

### Type A-065

Electrical data			
Type	A-065		
Article no.	0431 1400		
Electrical frequency	Hz	50	60
Nominal voltage	V	110/115	110/115
Rated power	P1 (W)	510	590
Nominal current	A	5.1	5.3
Speed	min <sup>-1</sup>	1400	1650
Duty cycle	%	100	100
Type of protection (motor)	IP	54	54

General technical data			
Delivery quantity 0 bar	l/min	65	65
Nominal pressure	bars	7	7
Safety pressure PS	bars	10	10
Noise level	dB(A)	68	70
Weight	kg	14.4	14.4
Dimensions (LxWxH)	mm	310 x 190 x 218	310 x 190 x 218

Ambient conditions during operation		
temperature	°C	-30 to +55

Spare part sets	Number re-quired	Item (see "6.4 Spare parts set for type KK40 / KV40")
Crankcase cover 0431100008	1	1, 17
Valve plate with lamellar valves 0431100009	1	6, 8, 24
Head Kit 0431100011	1	6, 9, 10, 12, 14, 17, 24

## Type B-065

Electrical data			
Type	B-065		
Article no.	0431 1300		
Electrical frequency	Hz	50	60
Nominal voltage	V	3 ph. 400	3 ph. 400
Rated power	P1 (W)	560	610
Nominal current	A	1.1	1.1
Speed	min <sup>-1</sup>	1440	1710
Duty cycle	%	100	100
Type of protection (motor)	IP	54	54

General technical data			
Delivery quantity 0 bar	l/min	65	65
Nominal pressure	bars	7	7
Safety pressure PS	bars	10	10
Noise level	dB(A)	68	70
Weight	kg	14.4	14.4
Dimensions (LxWxH)	mm	305 x 188 x 218	305 x 188 x 218

Ambient conditions during operation		
temperature	°C	-30 to +55

Spare part sets	Number re-quired	Item (see "6.4 Spare parts set for type KK40 / KV40")
Crankcase cover 0431100008	1	1, 17
Valve plate with lamellar valves 0431100009	1	6, 8, 24
Head Kit 0431100011	1	6, 9, 10, 12, 14, 17, 24

## Type D-075

Electrical data		
Type	D-075	
Article no.	0692 1000	
Electrical frequency	Hz	-
Nominal voltage	V	24 VDC
Rated power	P1 (W)	520
Nominal current	A	22
Speed	min <sup>-1</sup>	1800
Duty cycle	%	100
Type of protection (motor)	IP	54

General technical data		
Delivery quantity 0 bar	l/min	75
Nominal pressure	bars	7
Safety pressure PS	bars	10
Noise level	dB(A)	72
Weight	kg	14.1
Dimensions (LxWxH)	mm	333 x 154 x 218

Ambient conditions during operation		
temperature	°C	-30 to +40

Spare part sets	Number re-quired	Item (see "6.4 Spare parts set for type KK40 / KV40")
Crankcase cover 0431100008	1	1, 17
Valve plate with lamellar valves 0431100009	1	6, 8, 24
Head Kit 0431100011	1	6, 9, 10, 12, 14, 17, 24



## Type AG-132

Electrical data			
Type	AG-132		
Article no.	0431 2200		
Electrical frequency	Hz	50	60
Nominal voltage	V	230	230
Rated power	P1 (W)	820	940
Nominal current	A	3.9	4.1
Speed	min <sup>-1</sup>	1380	1630
Duty cycle	%	100	100
Type of protection (motor)	IP	54	54

General technical data			
Delivery quantity 0 bar	l/min	130	130
Nominal pressure	bars	7	7
Safety pressure PS	bars	10	10
Noise level	dB(A)	71	73
Weight	kg	18	18
Dimensions (LxWxH)	mm	340 x 276 x 190	340 x 276 x 190

Ambient conditions during operation		
temperature	°C	-30 to +55

Spare part sets	Number re-quired	Item (see "6.4 Spare parts set for type KK40 / KV40")
Crankcase cover 0431100015	1	1, 17
Valve plate with lamellar valves 0431100009	2	6, 8, 24
Head Kit 0431100011	2	6, 9, 10, 12, 14, 17, 24

## Type AG-132

Electrical data		
Type	AG-132	
Article no.	0431 2300	
Electrical frequency	Hz	60
Nominal voltage	V	110/115
Rated power	P1 (W)	1000
Nominal current	A	9.3
Speed	min <sup>-1</sup>	1700
Duty cycle	%	100
Type of protection (motor)	IP	54

General technical data		
Delivery quantity 0 bar	l/min	130
Nominal pressure	bars	7
Safety pressure PS	bars	10
Noise level	dB(A)	73
Weight	kg	18
Dimensions (LxWxH)	mm	340 x 276 x 194

Ambient conditions during operation		
temperature	°C	-30 to +55

Spare part sets	Number re-quired	Item (see "6.4 Spare parts set for type KK40 / KV40")
Crankcase cover 0431100015	1	1, 17
Valve plate with lamellar valves 0431100009	2	6, 8, 24
Head Kit 0431100011	2	6, 9, 10, 12, 14, 17, 24

**Type BG-132**

<b>Electrical data</b>			
Type	<b>BG-132</b>		
Article no.	<b>0431 2500</b>		
Electrical frequency	Hz	50	60
Nominal voltage	V	3 ph. 400	3 ph. 400
Rated power	P1 (W)	890	970
Nominal current	A	2	1.8
Speed	min <sup>-1</sup>	1440	1700
Duty cycle	%	100	100
Type of protection (motor)	IP	54	54

<b>General technical data</b>			
Delivery quantity 0 bar	l/min	130	130
Nominal pressure	bars	7	7
Safety pressure PS	bars	10	10
Noise level	dB(A)	71	73
Weight	kg	18	18
Dimensions (LxWxH)	mm	326 x 276 x 190	326 x 276 x 190

<b>Ambient conditions during operation</b>		
temperature	°C	-30 to +55

<b>Spare part sets</b>	<b>Number re-quired</b>	<b>Item (see "6.4 Spare parts set for type KK40 / KV40")</b>
Crankcase cover 0431100015	1	1, 17
Valve plate with lamellar valves 0431100009	2	6, 8, 24
Head Kit 0431100011	2	6, 9, 10, 12, 14, 17, 24



## 6.8 Technical data for piston vacuum pumps KV40

### Type AG-065E

Electrical data			
Type	A-065E		
Article no.	0431 4700		
Electrical frequency	Hz	50	60
Nominal voltage	V	230	230
Rated power	P1 (W)	390	390
Nominal current	A	1.7	1.7
Speed	min <sup>-1</sup>	1350	1600
Duty cycle	%	100	100
Type of protection (motor)	IP	54	54

General technical data			
Suction capacity $S_{eff}$	l/min	65	65
End pressure $P_{abs}$	mbar	120	120
Noise level	dB(A)	60	62
Weight	kg	14	14
Dimensions (LxWxH)	mm	305 x 188 x 218	305 x 188 x 218

Ambient temperature during operation		
temperature	°C	-30 to +55

Spare part sets	Number re-quired	Item (see "6.4 Spare parts set for type KK40 / KV40")
Crankcase cover 0431100008	1	1, 17
Valve plate with lamellar valves 0431100009	1	6, 8, 24
Head Kit 0431100011	1	6, 9, 10, 12, 14, 17, 24

### Type AG-065-2E

Electrical data			
Type	AG-065-2E		
Article no.	0431 3100		
Electrical frequency	Hz	50	60
Nominal voltage	V	230	230
Rated power	P1 (W)	530	590
Nominal current	A	2.5	2.6
Speed	min <sup>-1</sup>	1350	1600
Duty cycle	%	100	100
Type of protection (motor)	IP	54	54

General technical data			
Suction capacity $S_{eff}$	l/min	63	63
End pressure $P_{abs}$	mbar	30	30
Noise level	dB(A)	63	65
Weight	kg	16.5	16.5
Dimensions (LxWxH)	mm	322 x 276 x 180	322 x 276 x 180

Ambient temperature during operation		
temperature	°C	-30 to +55

Spare part sets	Number re-quired	Item (see "6.4 Spare parts set for type KK40 / KV40")
Crankcase cover 0431100015	1	1, 17
Valve plate with lamellar valves 0431100009	2	6, 8, 24
Head Kit 0431100011	2	6, 9, 10, 12, 14, 17, 24



**Type AG-132E**

<b>Electrical data</b>			
Type	AG-132E		
Article no.	0431 4400		
Electrical frequency	Hz	50	60
Nominal voltage	V	230	230
Rated power	P1 (W)	530	590
Nominal current	A	2.5	2.6
Speed	min <sup>-1</sup>	1350	1600
Duty cycle	%	100	100
Type of protection	IP	54	54

<b>General technical data</b>			
Suction capacity $S_{\text{eff}}$	l/min	130	130
End pressure $P_{\text{abs}}$	mbar	120	120
Noise level	dB(A)	63	65
Weight	kg	16.5	16.5
Dimensions (LxWxH)	mm	322 x 276 x 180	322 x 276 x 180

<b>Ambient temperature during operation</b>		
temperature	°C	-30 to +55



Spare part sets	Number re-quired	Item (see "6.4 Spare parts set for type KK40 / KV40")
Crankcase cover 0431100015	1	1, 17
Valve plate with lamellar valves 0431100009	2	6, 8, 24
Head Kit 0431100011	2	6, 9, 10, 12, 14, 17, 24

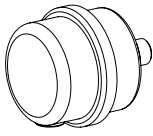
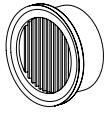
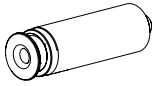
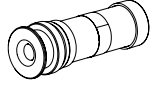
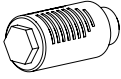

## 7 Oil-free piston compressors series KK70

### 7.1 Accessories for piston compressors KK

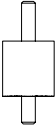
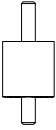
Filter and noise reducer				
	Description		Technical data	Remark
	Air intake filter Standard	0714200015	Special thread for: G1/4" and 1/4" NPT 2 µm filter mesh size	– complete, including air intake filter cartridge
	Air intake filter cartridge Standard	0714200025	2 µm filter mesh size	– Fits air intake filter Standard
	Air intake filter, long	0714200040	G1/4" 3 µm filter mesh size	– complete, including air intake filter cartridge
	Air intake filter cartridge, long	0714200050	3 µm filter mesh size	– Fits air intake filter long
	Air intake filter / noise reducer G1/4"	0714200070	G1/4"	

Vibration damper				
	Description		Technical data	Connector 1/ Connector 2
	Vibration damper set	0880100018	Ø30x32 Hardness: 34 Shore	M8x16/ M8x22
	Vibration damper set	0881-991-00	Ø40x40 Hardness: 40 Shore	M8x15/ M8x23
	Vibration damper set (34 sh)	0880-993-00	Ø30x32 Hardness: 34 Shore	M8x15/ M8 internal

## 7.2 Spare parts set for type KK70

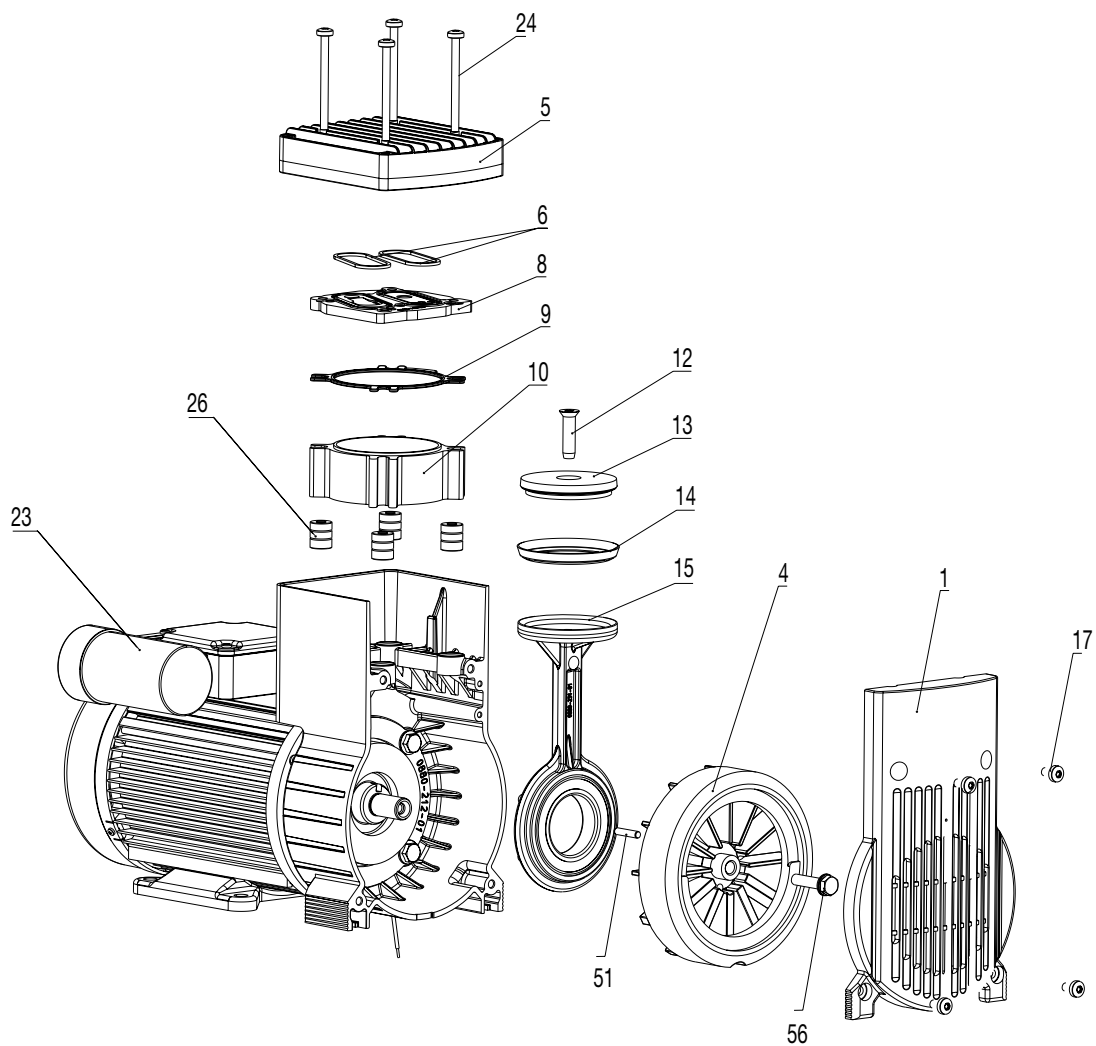

Figure 24: Oil-free piston compressors and piston vacuum pumps KK70 with item numbers for spare parts (schematic diagram)

### 7.3 Schematic drawing KK70

**i** The dimensions (diameter, height) of the vibration dampers are product-specific (refer to the "Accessories – Technical data" section). If different vibration dampers to the ones shown are used then their dimensions will change.

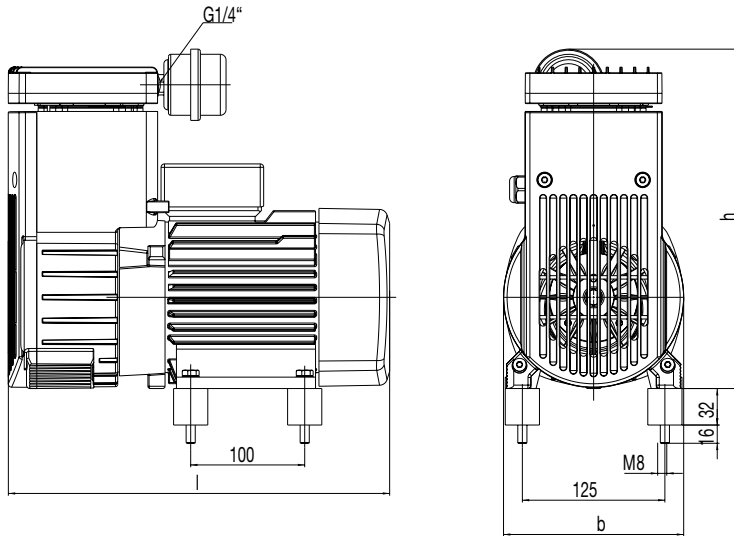

Figure 25: KK70; Type: A-100; B-100; D-100

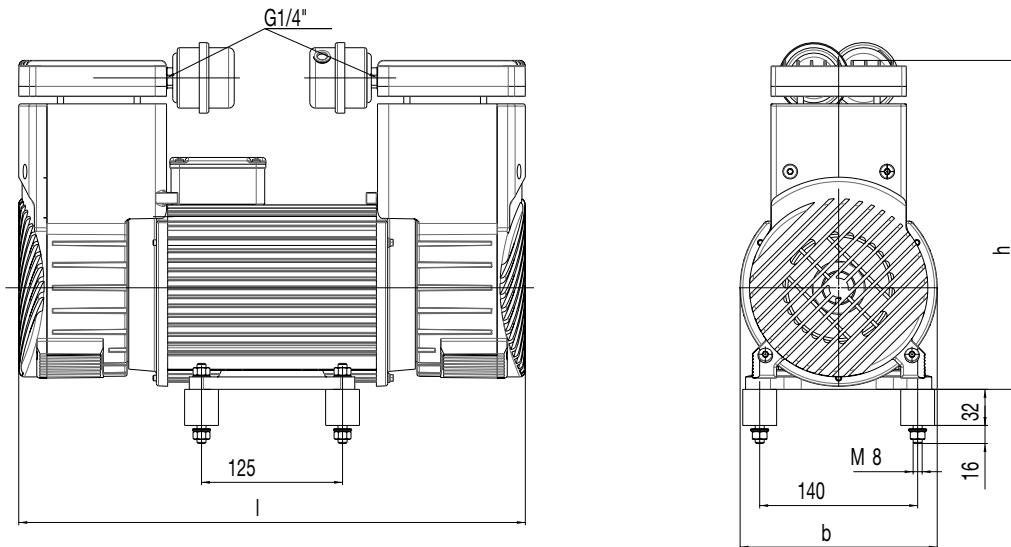

Figure 26: KK70; Type: A-200; B-200

## 7.4 Performance diagram KK70

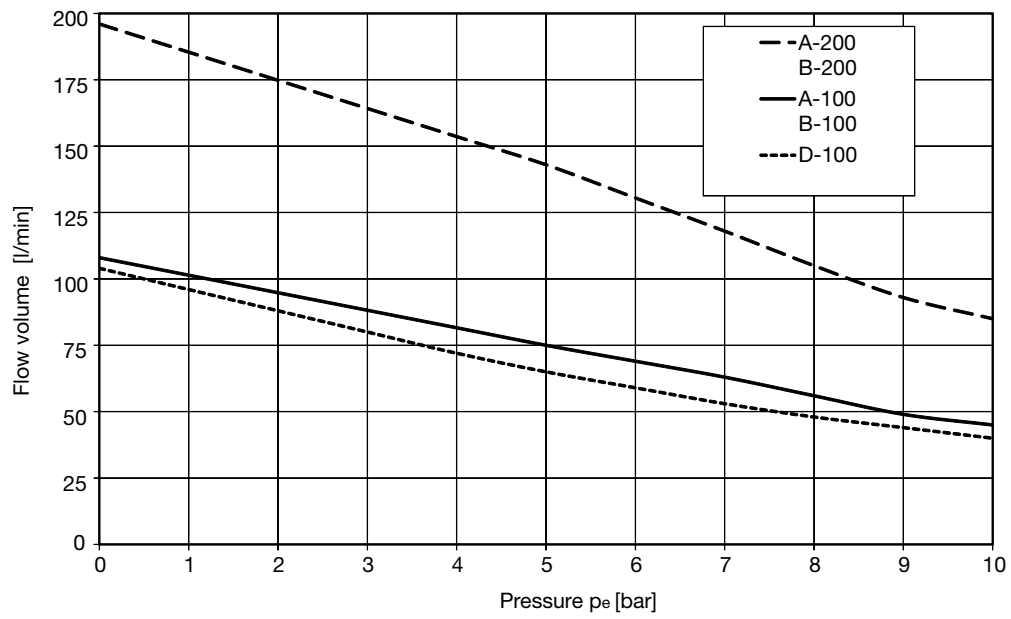

Figure 27: Delivery quantity at 50 Hz (60 Hz approx. +18%)



## 7.5 Technical data for piston compressors KK70

### Type A-100

Electrical data			
Type	A-100		
Article no.	0880-03		
Electrical frequency	Hz	50	60
Nominal voltage	V	100-110	100-127
Rated power	P1 (W)	1030	1110
Nominal current	A	12.9*	11.4*
Speed	min <sup>-1</sup>	1380	1700
Duty cycle	%	100	100
Type of protection (motor)	IP	44	44

General technical data			
Delivery quantity 0 bar	l/min	105	120
Nominal pressure	bars	8	8
Safety pressure PS	bars	10	10
Noise level	dB(A)	66	68
Weight	kg	21	21
Dimensions (LxWxH)	mm	340 x 200 x 283	340 x 200 x 283

Ambient conditions during operation		
temperature	°C	+5 to +40

\*Temperature switch, passive

Spare part sets	Number re-quired	Item (see "7.2 Spare parts set for type KK70")
Crankcase cover 0880100014	1	1, 17
Crankshaft with piston 0880100017	1	4, 6, 9, 10, 12, 13, 14, 15, 17, 24, 26, 51, 56
Valve plate with lamellar valves 0880100015	1	5, 6, 8, 24
Head Kit 0880100016	1	6, 9, 10, 12, 14, 17, 24

### Type A-100

Electrical data			
Type	A-100		
Article no.	0880-04		
Electrical frequency	Hz	50	60
Nominal voltage	V	230	230
Rated power	P1 (W)	920	970
Nominal current	A	4.9	4.3
Speed	min <sup>-1</sup>	1330	1660
Duty cycle	%	100	100
Type of protection (motor)	IP	54	54

General technical data			
Delivery quantity 0 bar	l/min	105	120
Nominal pressure	bars	8	8
Safety pressure PS	bars	10	10
Noise level	dB(A)	66	68
Weight	kg	20	20
Dimensions (LxWxH)	mm	355 x 200 x 283	355 x 200 x 283

Ambient conditions during operation		
temperature	°C	+5 to +40

\*Temperature switch, passive

Spare part sets	Number re-quired	Item (see "7.2 Spare parts set for type KK70")
Crankcase cover 0880100014	1	1, 17
Crankshaft with piston 0880100017	1	4, 6, 9, 10, 12, 13, 14, 15, 17, 24, 26, 51, 56
Valve plate with lamellar valves 0880100015	1	5, 6, 8, 24
Head Kit 0880100016	1	6, 9, 10, 12, 14, 17, 24

**Type B-100**

Electrical data			
Type	B-100		
Article no.	0880-05		
Electrical frequency	Hz	50	60
Nominal voltage	V	3-ph. 400	3-ph. 400
Rated power	P1 (W)	1000	920
Nominal current	A	3.1	2.1
Speed	min <sup>-1</sup>	1450	1740
Duty cycle	%	100	100
Type of protection (motor)	IP	44	44

General technical data			
Delivery quantity 0 bar	l/min	105	120
Nominal pressure	bars	8	8
Safety pressure PS	bars	10	10
Noise level	dB(A)	66	68
Weight	kg	20.3	20.3
Dimensions (LxWxH)	mm	330 x 200 x 283	330 x 200 x 283

Ambient conditions during operation		
temperature	°C	+5 to +40

Spare part sets	Number re-quired	Item (see "7.2 Spare parts set for type KK70")
Crankcase cover 0880100014	1	1, 17
Crankshaft with piston 0880100017	1	4, 6, 9, 10, 12, 13, 14, 15, 17, 24, 26, 51, 56
Valve plate with lamellar valves 0880100015	1	5, 6, 8, 24
Head Kit 0880100016	1	6, 9, 10, 12, 14, 17, 24

**Type D-100**

Electrical data		
Type	D-100	
Article no.	0448 1000	
Electrical frequency	Hz	-
Nominal voltage	V	12 VDC
Rated power	P1 (W)	590
Nominal current	A	49
Speed	min <sup>-1</sup>	1250
Duty cycle	%	S3 10 min. 50%
Type of protection (motor)	IP	54

General technical data		
Delivery quantity 0 bar	l/min	85
Nominal pressure	bars	8
Safety pressure PS	bars	9.5
Noise level	dB(A)	68
Weight	kg	20.5
Dimensions (LxWxH)	mm	368 x 176 x 292

Ambient conditions during operation		
temperature	°C	+5 to +40

Spare part sets	Number re-quired	Item (see "7.2 Spare parts set for type KK70")
Crankcase cover 0880100014	1	1, 17
Crankshaft with piston 0880100017	1	4, 6, 9, 10, 12, 13, 14, 15, 17, 24, 26, 51, 56
Valve plate with lamellar valves 0880100015	1	5, 6, 8, 24
Head Kit 0880100016	1	6, 9, 10, 12, 14, 17, 24



## Type D-100

Electrical data		
Type	D-100	
Article no.	0484 1000	
Electrical frequency	Hz	-
Nominal voltage	V	24 VDC
Rated power	P1 (W)	630
Nominal current	A	26
Speed	min <sup>-1</sup>	1320
Duty cycle	%	100
Type of protection (motor)	IP	54

General technical data		
Delivery quantity 0 bar	l/min	105
Nominal pressure	bars	8
Safety pressure PS	bars	10
Noise level	dB(A)	68
Weight	kg	20.5
Dimensions (LxWxH)	mm	368 x 176 x 292

Ambient conditions during operation		
temperature	°C	+5 to +40

Spare part sets	Number re-quired	Item (see "7.2 Spare parts set for type KK70")
Crankcase cover 0880100014	1	1, 17
Crankshaft with piston 0880100017	1	4, 6, 9, 10, 12, 13, 14, 15, 17, 24, 26, 51, 56
Valve plate with lamellar valves 0880100015	1	5, 6, 8, 24
Head Kit 0880100016	1	6, 9, 10, 12, 14, 17, 24

## Type D-100

Electrical data		
Type	D-100	
Article no.	0425 1000	
Electrical frequency	Hz	-
Nominal voltage	V	72 VDC
Rated power	P1 (W)	620
Nominal current	A	8.8
Speed	min <sup>-1</sup>	1300
Duty cycle	%	100
Type of protection (motor)	IP	54

General technical data		
Delivery quantity 0 bar	l/min	105
Nominal pressure	bars	8
Safety pressure PS	bars	10
Noise level	dB(A)	68
Weight	kg	20.5
Dimensions (LxWxH)	mm	368 x 176 x 292

Ambient conditions during operation		
temperature	°C	-30 to +40

Spare part sets	Number re-quired	Item (see "7.2 Spare parts set for type KK70")
Crankcase cover 0880100014	1	1, 17
Crankshaft with piston 0880100017	1	4, 6, 9, 10, 12, 13, 14, 15, 17, 24, 26, 51, 56
Valve plate with lamellar valves 0880100015	1	5, 6, 8, 24
Head Kit 0880100016	1	6, 9, 10, 12, 14, 17, 24



**Type D-100**

Electrical data		
Type	D-100	
Article no.	0422 1000	
Electrical frequency	Hz	-
Nominal voltage	V	110 VDC
Rated power	P1 (W)	720
Nominal current	A	6.5
Speed	min <sup>-1</sup>	1320
Duty cycle	%	100
Type of protection (motor)	IP	54

General technical data		
Delivery quantity 0 bar	l/min	105
Nominal pressure	bars	8
Safety pressure PS	bars	10
Noise level	dB(A)	68
Weight	kg	20.5
Dimensions (LxWxH)	mm	368 x 176 x 292

Ambient conditions during operation		
temperature	°C	+5 to +40

Spare part sets	Number re-quired	Item (see "7.2 Spare parts set for type KK70")
Crankcase cover 0880100014	1	1, 17
Crankshaft with piston 0880100017	1	4, 6, 9, 10, 12, 13, 14, 15, 17, 24, 26, 51, 56
Valve plate with lamellar valves 0880100015	1	5, 6, 8, 24
Head Kit 0880100016	1	6, 9, 10, 12, 14, 17, 24

**Type A-200**

Electrical data		
Type	A-200	
Article no.	0881-01	
Electrical frequency	Hz	50
Nominal voltage	V	230
Rated power	P1 (W)	1370
Nominal current	A	6.3
Speed	min <sup>-1</sup>	1390
Duty cycle	%	100
Type of protection (motor)	IP	54

General technical data		
Delivery quantity 0 bar	l/min	195
Nominal pressure	bars	8
Safety pressure PS	bars	10
Noise level	dB(A)	69
Weight	kg	33
Dimensions (LxWxH)	mm	445 x 205 x 295

Ambient conditions during operation		
temperature	°C	+5 to +40

Spare part sets	Number re-quired	Item (see "7.2 Spare parts set for type KK70")
Crankcase cover 0880100014	2	1, 17
Crankshaft with piston 0880100017	2	4, 6, 9, 10, 12, 13, 14, 15, 17, 24, 26, 51, 56
Valve plate with lamellar valves 0880100015	2	5, 6, 8, 24
Head Kit 0880100016	2	6, 9, 10, 12, 14, 17, 24
Capacitor 25µF 450 V 9000-104-0008ET	1	23

**Type B-200**

<b>Electrical data</b>			
Type	<b>B-200</b>		
Article no.	<b>0881-05</b>		
Electrical frequency	Hz	50	60
Nominal voltage	V	3-ph. 400	3-ph. 400
Rated power	P1 (W)	1400	1630
Nominal current	A	2.9	2.9
Speed	min <sup>-1</sup>	1450	1725
Duty cycle	%	100	100
Type of protection (motor)	IP	54	54

<b>General technical data</b>			
Delivery quantity 0 bar	l/min	195	225
Nominal pressure	bars	8	8
Safety pressure PS	bars	10	10
Noise level	dB(A)	69	71
Weight	kg	31	31
Dimensions (LxWxH)	mm	445 x 205 x 295	445 x 205 x 295

<b>Ambient conditions during operation</b>		
temperature	°C	+5 to +40

\*Temperature switch, passive

<b>Spare part sets</b>	<b>Number re-quired</b>	<b>Item (see "7.2 Spare parts set for type KK70")</b>
Crankcase cover 0880100014	2	1, 17
Crankshaft with piston 0880100017	2	4, 6, 9, 10, 12, 13, 14, 15, 17, 24, 26, 51, 56
Valve plate with lamellar valves 0880100015	2	6, 8, 24
Head Kit 0880100016	2	6, 9, 10, 12, 14, 17, 24

## 8 Declaration of conformity for machines in accordance with the 2006/42/EC Directive

We hereby declare that the unit described below conforms to all requirements of the machine directive 2006/42/EC.

The unit named below fulfills the requirements of the following directives:

- Electromagnetic Compatibility (EMC) Directive 2014/30/EU
- RoHS directive 2011/65/EU

Manufacturer's name:	Dürr Technik GmbH & Co. KG
Manufacturer's address:	Pleidelsheimer Straße 30 D-74321 Bietigheim-Bissingen

Reference number:	KK/KV-unit
Article designation:	Compressor / vacuum pump
From the serial number:	H400000

We hereby declare that the unit may only be commissioned once it has been established that the machine into which this unit is to be installed complies with the provisions as set out in Machinery Directive 2006/42/EC.

### The following harmonised standards and other standards have been applied:

DIN EN 1012-1:2011-02  
 DIN EN 1012-2:2011-12  
 DIN EN 60034-1:2011-02  
 DIN EN 60034-5:2007-09  
 DIN EN 60335-1:2014-11  
 DIN EN 61000-6-2:2011-06  
 DIN EN 61000-6-3:2012-11  
 DIN EN 60204-1:2010-05  
 DIN EN 50106:2009-05  
 DIN EN ISO 12100:2013-08

Bietigheim-Bissingen, 20/04/2016

Andreas Ripsam  
 Executive Board of Dürr Technik

Proof of signature in the  
 Original document held by Dürr Technik

## 9 Operation

### 9.1 Oil-free piston compressors KK

#### Modular structure

The basic model consists of a compressor head with an electric motor.

The following electric motors are available:

Type A	Single-phase ac motors
Type B	Three-phase motors
Type D	DC permanent-magnet motors

With the exception of the 3-phase motors, a temperature switch is integrated in most electric motors for additional thermal protection. The unit shuts down automatically if the temperature switch is triggered.

 Units with a temperature switch start again automatically after they have cooled down.

 On all electric motors with nominal current greater than 10 A the temperature switch has passive wiring. An additional relay must be used for the thermal cut-off.

#### Functional description

Air is drawn in from the surrounding atmosphere through the air intake filter (1). This air is compressed by the piston (3) in the cylinder (6). The inlet valve (2) or the outlet valve (4) cuts off the respective flow direction. The compressed air flows through the air line (5) to the consumer.

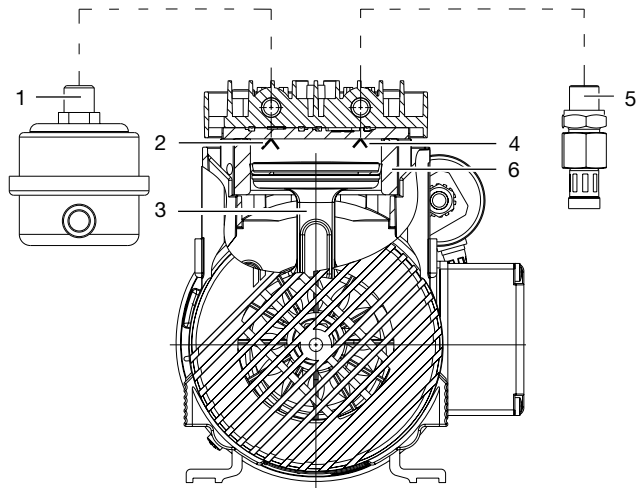

### 9.2 Oil-free piston vacuum pumps KV

#### Modular structure

The basic model consists of a pump head with an electric motor.

The following electric motors are available:

Type A	Single-phase ac motors
Type B	Three-phase motors
Type D	DC permanent-magnet motors.

With the exception of the 3-phase motors, all electric motors are fitted with an integrated temperature switch for additional thermal protection. The unit shuts down automatically if the temperature switch is triggered.

 Units with a temperature switch start again automatically after they have cooled down.

 An additional relay must be used for the thermal cut-off on all electric motors with a nominal current greater than 10 A.

#### Functional description

Air is drawn in via the intake (1). The air is drawn into the cylinder (6) by the piston (3). The inlet valve (2) or the outlet valve (4) cuts off the respective flow direction. The aspirated air is expelled into the atmosphere via a noise reducer (5).

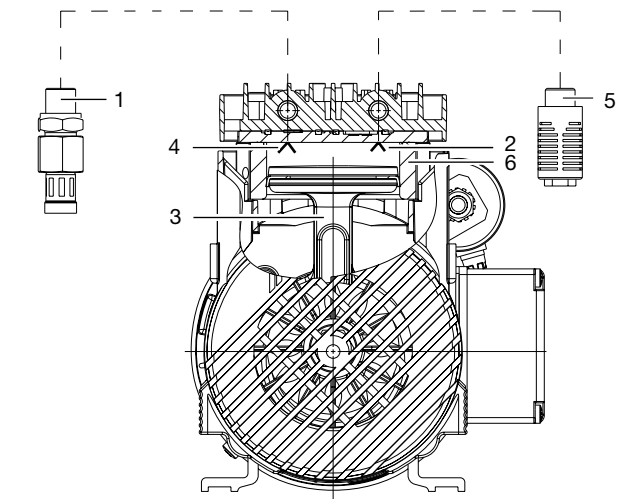



## 10 Requirements

### 10.1 Installation/setup room

The room chosen for set up must fulfil the following requirements:

- Dry, well ventilated room
- Should not be a purpose-made room (e. g. boiler room or wet room)
- Set up the unit on a clean, level and sufficiently stable surface (take the weight of the unit into account).
- The socket-outlet must be easily accessible.
- The type plate of the unit must be easily readable (also after installation).
- The unit must be easily accessible for operation and maintenance.
- Once the unit has been installed, the connecting terminals must be easily accessible when removing/opening housing access.
- Maintain sufficient distance from the wall (min. 30 mm to 40 mm).

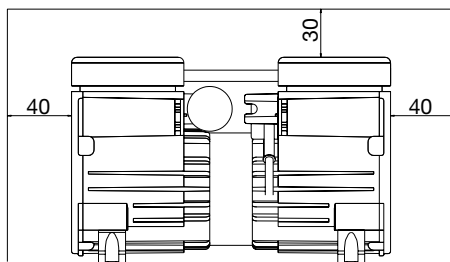
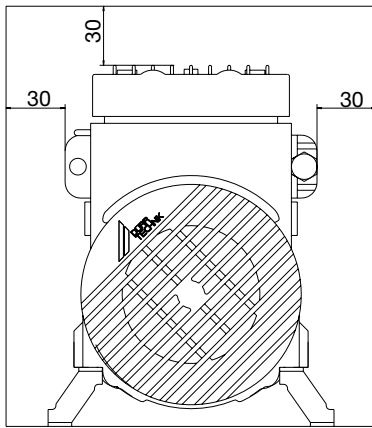

The air is filtered when it is sucked in. This does not alter the composition of the air. The source of the air taken in should be free of any harmful substances (e.g. do not draw in air from an underground garage or directly next to a suction machine).



#### NOTICE

##### Risk of overheating due to insufficient ventilation

The units generates heat. Possibility of heat damage and/or reduced service life of the unit.

- > Do not install the unit on a closed housing, for ventilation reasons.
- > Air must be able to flow in and out unobstructed.
- > Ventilation openings must be sufficiently large.
- > Installed units may require an independent ventilation system in unfavourable cases (applicable in case of installation inside a close housing).

### 10.2 Vibration dampening

The unit generates vibrations. Suitable vibration dampers must be used to damp these vibrations.



#### CAUTION

The use of rigid connections may damage the units or the system in which the units have been installed.

- > Do not install rigid connection lines between unit and system.

### 10.3 Installation position and fastening

Install the units as near as possible to the horizontal. Other fitting positions must be agreed in advance with Dürr Technik.

### 10.4 Silencer

In vacuum operation, the noise levels are raised at the venting port. For this reason, a suitable noise reducer should be used that discharges the aspirated air into the atmosphere. Noise reducers are available as accessories (see "Accessories for piston vacuum pumps KV" for the relevant series).

## 11 Electrical installation

### 11.1 Electrical connection using a mains plug

- › The unit may only be connected to a correctly installed socket outlet.
- › Make sure that none of the electrical cables leading to the unit are under any mechanical tension.
- › The socket-outlet must be easily accessible.
- › Before commissioning, verify that the power supply voltage complies with the voltage specifications of the model identification plate.



**DANGER**

**Risk of electric shock due to defective power cord**

- › The power cord must not be allowed to come into contact with any hot surfaces on the unit.
- › Route power cords without mechanical tension.
- › Connect the mains plug to an earthed socket outlet.
- › The unit will start immediately after connection of the mains plug.

### 11.2 Electrical connection without a mains plug



**DANGER**

**Connection to the power supply may only be performed by a qualified electrician.**

- › Comply with the regulations from the local power supply companies.
- › Connect the unit to a power supply source with a correctly installed protective earth conductor. (Exception: units with DC permanent-magnet motors.)
- › Before commissioning, verify that the power supply voltage complies with the voltage specifications of the type plate. Ensure that the current circuit on the building side has appropriate fuse protection.

If the unit is permanently connected to the power supply, a cut-off device (e.g. power circuit breaker) with a contact gap of at least 3 mm must be provided in the vicinity of the unit. The disconnecting device must comply with the standard 60204-1:2010-05, 5.3.

Comply with the information provided in the wiring diagrams, label or circuit diagram in the terminal box when making the electrical connection.

### 11.3 IP protection type



**DANGER**

**Comply with the IP protection type for protecting the units against contact, foreign matter, and moisture**

Failure to comply with this information can result in electric shock, personal injury, or material damage.

- › The units must only be installed or used in accordance with their type of protection.
- › The owner is to ensure that the unit is provided with the IP protection type in accordance with the purpose for which it is used.



The term "IP protection type" (International Protection) is defined by IEC/EN 60529 "Type of protection by housing (IP Code).

The units are available with different types of protection (IP00 to IP54 - see see "4 Oil-free piston compressors and piston vacuum pumps series KK8 / KV8" on page 5).

Units with a IP00 protection type provide no protection against contact, foreign matter, and moisture. The owner is responsible for ensuring that the units are only installed or used in accordance with their protection type.

A fixed electrical installation which complies with wiring regulations is required.

If the terminal box is fitted (e.g. 2 cylinders A/B-062), the electrical components are covered. The IP rating is then IP20.

### 11.4 Direction of rotation

Single-phase AC motors and 3-phase AC motors have no preferred direction of rotation.

The direction of rotation of DC permanent-magnet motors is specified on the motor.

### 11.5 Fuse protection of the supply current circuit



**DANGER**

**Insufficient fuse protection of the units**

Insufficient fuse protection of the units can result in fire, electric shock, personal injury or material damage.

- › Protect the supply current circuits at all poles in accordance with the nominal current of the electric motors.
- › In the case of unmonitored installations, overcurrent protection in accordance with EN 60204-1:2010-05, 7.2 must be provided.



We recommend the installation of a motor protection circuit breaker. A minimum of one line cable fuse with nominal current + 10% unless specified otherwise.

### 11.6 Motor protection - temperature

#### Single-phase ac motors

The single-phase AC motors are fitted with a normally-closed temperature switch. This prevents overheating of the motor winding in the case of excessive ambient temperatures. The unit shuts down if it overheats.

The units AG-132, art. no. 0431 2300 (KK40) and A-100, art. no. 0880-03 (KK70) are fitted with a passive temperature switch. A suitable relay that switches all poles and is open when deenergised must be connected if necessary. The connection points are located in the terminal box. The temperature switch shuts the unit down if it overheats.

Oil-free compressor stations and accessories must be electrically connected in accordance with the circuit diagrams "11.7 Circuit diagrams".

#### 3-phase motors

The 3-phase motors are not fitted with a temperature protection device.

In the event of a machine malfunction (e.g. as a result of a blackout, phase failure, start-up under pressure, mechanical faults of the unit or a short circuit), **there is no protection.**

The electric motor can overheat!

The electrical wiring must be done in accordance with the circuit diagrams see "11.7" on page 62.

Oil-free compressor stations and accessories must be electrically connected in accordance with the circuit diagrams "11.7 Circuit diagrams".

### DC permanent-magnet motors

The DC permanent-magnet motors are fitted with a passive temperature switch. A suitable relay that switches all poles and is open when deenergised must be connected if necessary. The connection points are located in the terminal box. The temperature switch shuts the unit down if it overheats.

A sufficient voltage supply must be present. The maximum starting current must be limited to approx. 200% of the nominal current.

Some units are fitted with an EMC interference suppression filter in order to comply with the limit values stipulated in the EMC directive. The EMC filter must not be fixed directly to the unit because of the vibrations.

The electrical wiring must be done in accordance with the circuit diagrams "11.7 Circuit diagrams".

Oil-free compressor stations and accessories must be electrically connected in accordance with the circuit diagrams "11.7 Circuit diagrams".



Units with a temperature switch start again automatically after they have cooled down.



#### DANGER

**The temperature switch may suffer damage from a motor lockage or a short circuit in the motor winding**

Insufficient fuse protection of the electric motors can result in fire, electric shock, personal injury or material damage.

› Installation of a circuit breaker.



#### DANGER

**Insufficient fuse protection of the electric motors in unmonitored installations**

Insufficient fuse protection of the electric motors can result in fire, electric shock, personal injury or material damage.

› Installation of a circuit breaker.

› The temperature switch must be connected to a suitable relay.

## 11.7 Circuit diagrams

### Compressor unit

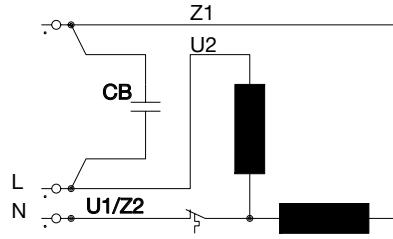

Figure 28: Single-phase ac motors

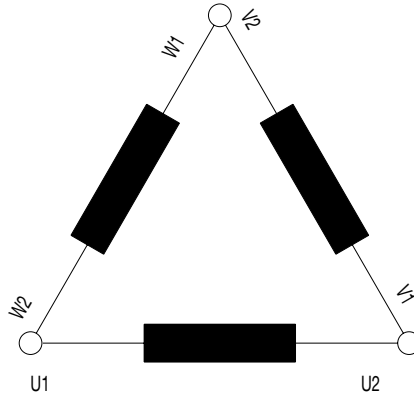

Figure 29: 3-phase motors, triangle connection

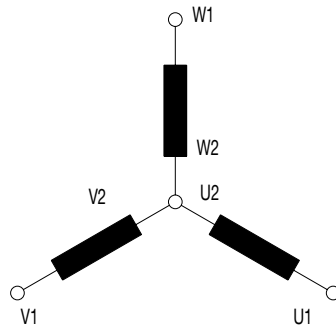

Figure 30: 3-phase motors, star connection



## Oil-free compressor stations

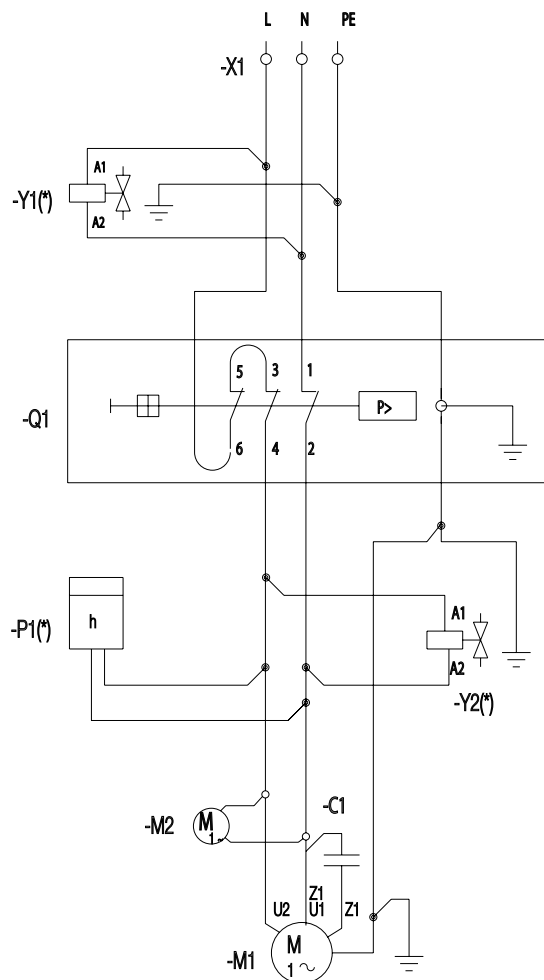

Figure 31: Installation of a compressor unit with single-phase AC motors in a compressor station

- X1 Mains connection
- Y1 Soleinoid valve
- Y2 Soleinoid valve
- Q1 Pressure switch
- P1 Operating time counter
- M1 Compressor motor
- M2 Ventilator

EN

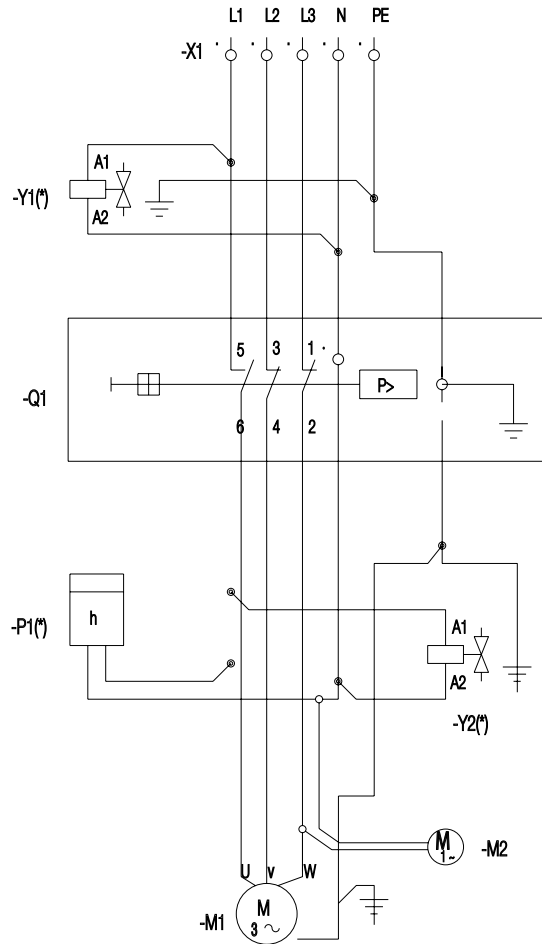

Figure 32: Installation of a compressor unit with 3-phase AC motor in a compressor station

- X1 Mains connection
- Y1 Solenoid valve
- Y2 Solenoid valve
- Q1 Pressure switch
- P1 Operating time counter
- M1 Compressor motor
- M2 Ventilator

DC permanent-magnet motors

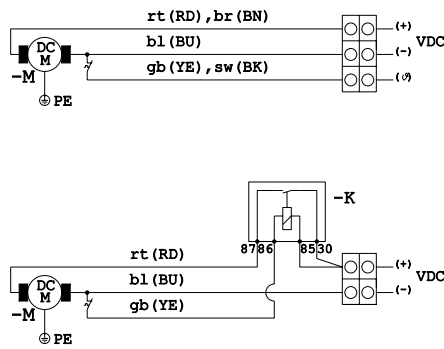

Figure 33: Motor connection of compressor unit with DC permanent-magnet motor

- M Compressor motor
- K Relais

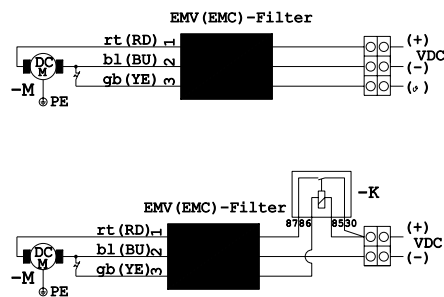

Figure 34: Connection of interference suppression filter for compressor units with DC permanent-magnet motors

- M Compressor motor
- K Relais

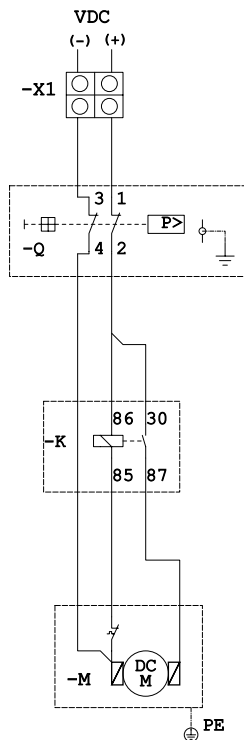
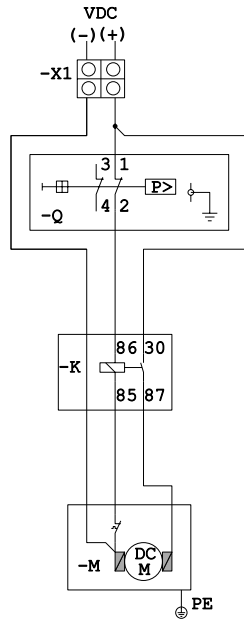

Figure 35: Installation of a compressor unit with DC permanent-magnet motor in a compressor station – connection of pressure switch with direct wiring (for small currents)

- X1 Mains connection
- Q Pressure switch
- K Relais
- M Compressor motor

EN



*Figure 36: Installation of a compressor unit with DC permanent-magnet motor in a compressor station – connection of pressure switch with indirect wiring via relay (for high currents)*

- X1 Mains connection
- Q Pressure switch
- K Relais
- M Compressor motor

## 12 Commissioning and first start-up

### 12.1 Remove the transport locks

The unit is securely protected with packaging material to ensure safe transportation.

- › Remove the packaging material.
- › Remove the protective film.
- › Check the unit for damage in transit.

### 12.2 Connect oil-free piston compressor

 Depending on the product, the units are designed for a specific nominal pressure (see "4 Oil-free piston compressors and piston vacuum pumps series KK8 / KV8").

If this nominal pressure is exceeded, the service life of the product is reduced.

The connections for the air inlet and air outlet are located on the cylinder head. The atmospheric air is drawn in via the air intake filter on the air inlet side. On the air outlet side, the compressed air flows through the air line to the consumer.

#### Air inlet

The air inlet opening is located on the cylinder head. A suitable air intake filter must be mounted on the air intake filter to preserve the service life of the unit.

The air inlet opening is indicated by arrows pointing towards the cylinder head.

- › Mount air intake filter on the air inlet opening (G 1/4" internal thread or G1/8" (for KK8)) of the cylinder head

#### Air outlet

The air outlet opening is located on the cylinder head.

The air outlet opening is indicated by arrows pointing away from the cylinder head.

- › Mount shielded, temperature-resistant compressed-air hose on the air outlet opening (G 1/4" internal thread or G1/8" (for KK8)) of the cylinder head.

#### Start against pressure

The units will not start up against pressure

- › Before the unit is started up, it must always be purged on the pressure side (e.g. via a mechanical relief valve in the pressure switch or via a solenoid valve).
- › There must be a start-up volume of at least 130 ml between the unit and the non-return valve.

Exception: The start-up volume is integrated in the cylinder head as standard in the series KK 40.

#### Operating the unit in a system

If the unit is installed in a system, the safety pressure must not be exceeded (see "4 Oil-free piston compressors and piston vacuum pumps series KK8 / KV8"). Ensure that the safety pressure does not exceed permissible overpressure values by providing of a safety device (e.g. safety valve, solenoid valve etc.).

The operating or working pressure may not exceed the nominal pressure of the unit. Accessories for pressure control, e.g. pressure switches and pressure reducers, are necessary in order to ensure a constant mains pressure during operation.

Depending on the application, control systems, valve units, containers or other accessories are required for safe operation.

## 12.3 Connecting oil-free piston vacuum pumps

### Suction side

The suction opening is located on the cylinder head.

The suction opening is marked with arrows that point towards the cylinder head.

- › Mount the suction line on the air inlet opening (G 1/4" internal thread or G1/8" (for KK8)) of the cylinder head.

 When the unit is shut down, air flows into the evacuated space.

If this is not wanted, a non-return valve must be integrated into the suction line. Filters combined with a non-return valve are available as accessories (see "Accessories for oil-free vacuum pumps KV" for the relevant series)

### Exhaust air side

The exhaust air opening is located on the cylinder head.

The exhaust air opening is marked with arrows that point away from the cylinder head. A noise reducer can be installed (see "5.2 Accessories for piston vacuum pumps KV") in order to reduce the exhaust air noises.

- › Fit a suitable noise reducer on the exhaust air opening (G 1/4" internal thread) of the cylinder head. A G1/8" to G1/4" reduction adapter is required for series KV8.

### Startup against vacuum

The units will not start up against vacuum

- › Before the unit is started up, it must always be purged on the suction side (e.g. via a mechanical relief valve in the pressure switch or via a solenoid valve).
- › There must be a start-up volume of at least 130 ml between the unit and the non-return valve (if present).

## 13 Maintenance



### CAUTION

#### Burns from hot surfaces

The surfaces of the unit are hot during operation

› Allow surfaces to cool down before performing operating or maintenance work.



De-energize the unit prior to working on it or in the event of potential danger (e. g. pull the mains plug) and prevent it from being switched back on again.

### 13.1 Maintenance schedule

Maintenance interval	Maintenance work
Monthly	› Clean the surface of the unit with a non-fuzzing cloth. Keep the ventilation openings of the crankcase chamber and cylinder head free from dust and impurities.
Annually	› Replacement of the air intake filter cartridge – if there is a high concentration of dust, this must be done every six months (see "Replace the air intake filter cartridge").
Every 4 years	› Change vibration dampers – for mobile application, every 2 years
Every 1000 operating hours	› On DC permanent-magnet motors type D: check the carbon brushes and replace them if they are shorter than the following lengths: › Type D-100 --> length L < 15 mm › Type D-061 --> length L < 9 mm › Type D-030 and D-040 --> length L < 8 mm

### Replace the air intake filter cartridge

- › Open the cover of the air intake filter by turning it clockwise.
- › Take out the air intake filter cartridge.

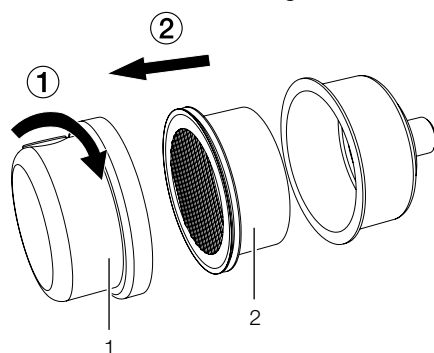

- 1 Air intake filter lid
- 2 Intake filter cartridge

- › Insert a new air intake filter cartridge.
- › Close the cover of the air intake filter by turning it anti-clockwise.

### Replace the vibration dampers

Follow the installation instructions included in the relevant spare parts set.

### Changing the carbon brushes

Follow the installation instructions included in the relevant spare parts set.

# ? Troubleshooting

## 14 Units for alternating current

 Any repairs above and beyond routine maintenance must only be carried out by suitably qualified personnel or by one of our service technicians.

 De-energize the unit prior to working on it or in the event of potential danger (e. g. pull the mains plug) and prevent it from being switched back on again.

Fault	Probable cause	Solution
<b>Unit does not start</b>	No power supply voltage	› Inform an electrician. Check mains fuse and if possible, switch on unit again. If the safety fuse is defective, replace it.
	Undervoltage or overvoltage	› Inform an electrician. Measure power supply voltage.
	Condensor defective	› Notify electrician/engineer. Check condenser and replace if necessary.
	Motor defective	› Replace the unit.
	Temperature switch in the motor (not fitted in all units) has switched off	1. Allow the unit to cool down. Ensure better cooling. Warning: unit restarts automatically.
	1. High ambient temperature 2. Mechanical sluggishness 3. Pressure in the line	2. Factory repair. 3. Evacuate air from the suction volume.
	Air intake filter cartridge blocked	› Insert a new air intake filter cartridge.
<b>Output drops.</b>	Lines, hoses or connections leaking	› Inform a service technician. Check / renew lines, hoses or connections.
	Air intake filter cartridge soiled	› Replace the air intake filter cartridge at least 1x per year. The air intake filter cartridge must never be cleaned.
	Defective seals	› Inform a service technician. Replace seals.
	Head kit leaking as a result of wear and/or for one or more of the following reasons:	Inform a service technician. Replace the cup seal and gaskets and possibly the piston (follow the installation instructions included in the relevant spare parts set). If necessary/appropriate:
	– Soiling – Excessive ambient temperature – Unsuitable materials drawn in	– Install the filter upstream or replace the filter. – Ensure that cooling is more effective. – Only convey approved materials.
	Defective valve plate	› Inform a service technician. Replace valve plate and seals.
<b>Unit too noisy</b>	Bearing damaged	› Inform a service technician.
	Vibrations are being transmitted to the housing	› Use suitable vibration dampers.
	Defective vibration dampers	› Install new vibration dampers.



## 15 Units for direct current

 Any repairs above and beyond routine maintenance must only be carried out by suitably qualified personnel or by one of our service technicians.

 De-energize the unit prior to working on it or in the event of potential danger (e. g. pull the mains plug) and prevent it from being switched back on again.

Fault	Probable cause	Solution
<b>Unit does not start</b>	Operating voltage too low	› Inform an electrician. Charge or replace the battery, check the voltage supply.
	Voltage supply interrupted	› Inform an electrician. Check supply line.
	Defective relay	› Inform an electrician. Replace relay.
	Motor defective	› Replace the unit.
	Temperature switch in the motor (not fitted in all units) has switched off	1. Allow the unit to cool down. Ensure better cooling. Warning: unit restarts automatically.
	1. High ambient temperature	2. Factory repair.
	2. Mechanical sluggishness	3. Factory repair.
	3. Temperature switch defective	
Carbon brushes worn down	› Factory repair or repair by electrician. (Follow the installation instructions included in the relevant spare parts set).	
Commutator defective or worn down	› Factory repair.	
Mechanical sluggishness	› Factory repair.	
<b>Output drops.</b>	Voltage too low	› Inform an electrician. Check the battery voltage and the power supply.
	Lines, hoses or connections leaking	› Inform a service technician. Check / renew lines, hoses or connections.
	Air intake filter cartridge or exhaust filter is clogged	› Replace the air intake filter cartridge or exhaust filter at least 1x per year.
	Defective seals	› Inform a service technician. Replace seals.
	Head kit leaking as a result of wear and/or for one or more of the following reasons:	Inform a service technician. Replace the cup seal and gaskets as well as possibly the piston. (Follow the installation instructions included in the relevant spare parts set). If necessary/appropriate:
	– Soiling	– Install the filter upstream or replace the filter.
	– Excessive ambient temperature	– Ensure that cooling is more effective.
– Unsuitable materials drawn in	– Only convey approved materials.	
Defective valve plate	› Inform a service technician. Replace the valve plate and seals.	
<b>Unit too noisy</b>	Bearing damaged	› Factory repair
	Unsuitable noise reducer	› Mount a suitable noise reducer (refer to the list of accessories)
	Defective head kit	› Inform a service technician. Replace the cup seal and gaskets as well as possibly the piston.
	Vibrations are being transmitted to the housing	› Use suitable vibration dampers.
	Defective vibration dampers	› Install new vibration dampers.

Fault	Probable cause	Solution
<b>Carbon brushes wearing too rapidly</b>	Operating voltage too low	› Inform an electrician. Charge or replace the battery, check the voltage supply.
	Deep scoring on commutator	› Factory repair.
	Carbon brushes and commutator too hot (> 160°C)	› Inform an electrician. Check voltage. – Ensure better cooling. – If the current consumption is too high, replace the unit.

EN



## Addresses

### Service

Dürr Technik GmbH & Co. KG  
74301 Bietigheim-Bissingen  
Telephone 0 71 42 / 90 22 - 20  
Fax 0 71 42 / 90 22 - 99  
e-mail: [service@duerr-technik.de](mailto:service@duerr-technik.de)

### Replacement order

Telephone 0 71 42 / 9022 - 0  
Fax 0 71 42 / 9022 - 99  
e-mail: [office@duerr-technik.de](mailto:office@duerr-technik.de)

The following information is required when ordering spare parts:

- Type designation and item number
- Order number as appears on the spare parts list
- Quantity required
- Exact shipping address
- Shipping information

### Repairs/return delivery

Ensure that the unit is **depressurized** before transport! Use the original packaging when returning units, if possible. Always pack the units in a plastic bag. Use recyclable packing material.

### Return delivery address:

Dürr Technik GmbH & Co. KG  
Pleidelsheimer Straße 30  
74321 Bietigheim-Bissingen  
-Germany-

### International addresses for Dürr Technik

[www.duerr-technik.com](http://www.duerr-technik.com)

Dürr Technik GmbH & Co. KG  
Pleidelsheimer Strasse 30  
74321 Bietigheim-Bissingen  
Germany  
Fon: +49 7142-90 22 -0  
[www.duerr-technik.com](http://www.duerr-technik.com)  
[office@duerr-technik.de](mailto:office@duerr-technik.de)

