

Oil-free compressor unit E-Bull

EN

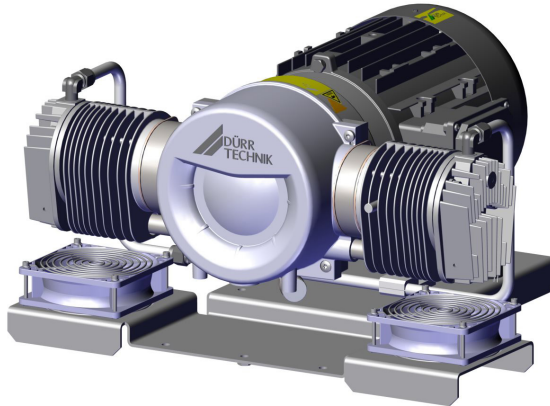

Installation and operating instructions

CE

1037100150L02



 **DÜRR
TECHNIK**

1905V001

Contents



Important information

1 About this document	2
1.1 Warnings and symbols	2
1.2 Copyright information	2
2 Safety	3
2.1 Intended use	3
2.2 Improper use	3
2.3 General safety information	3
2.4 Specialist personnel	3
2.5 Electrical safety	3
2.6 Only use original parts	3
2.7 Transportation and storage	4
2.8 Disposal	4



Product description

3 Overview	5
3.1 Scope of delivery	5
3.2 Spare parts and accessories	6
4 Technical data	7
4.1 Schematic drawing	7
4.2 Technical data	8
4.3 Declaration of conformity for machines in accordance with the 2006/42/EC Directive	10



Assembly

5 Requirements	11
5.1 Setup	11
5.2 Vibration dampening	11
5.3 Installation position and fastening	11
5.4 Ventilator	12
6 Electrical installation	12
6.1 Electrical connection without a mains plug	12
6.2 IP protection type	12
6.3 Fuse protection of the supply current circuit	13
6.4 Circuit diagrams	13
6.5 Motor protection - temperature	13

7 Commissioning	14
7.1 Remove the transport locks	14
7.2 Connect oil-free piston compressor	14



Usage

8 Operation	16
8.1 Switching the unit on/off	16
9 Maintenance	17
9.1 Maintenance schedule	17
9.2 Replace the air intake filter cartridge	18
9.3 Replace the vibration dampers	18
10 Taking out of use	19



Troubleshooting

11 Tips for operators and service technicians	20
--	----



Contact

12 Addresses	21
12.1 Returns / Repairs	21
12.2 To order spare parts	21
12.3 Service	21
12.4 Addresses worldwide	21



Important information

1 About this document

These installation and operating instructions represent a part of the unit. They correspond to the relevant version of the unit and the status of technology valid at the time of its market launch.



In the event that the instructions and notes in these installation and operating instructions for are not observed, Dürr Technik accepts no warranty or liability of any kind for the safe operation and reliable function of the units.

This translation was prepared to the best of our knowledge. The original German language version of the manual is the definitive version. Dürr Technik is not liable for translation errors.

1.1 Warnings and symbols

Warnings

The warnings in this document are intended to draw your attention to possible injury to persons or damage to machinery.

The following warning symbols are used:



General warning symbol



Warning – dangerous high voltage



Warning – hot surfaces



Warning - automatic start-up of the unit

The warnings are structured as follows:



Description of the type and source of danger

Here you will find the possible consequences of ignoring the warning

- › Follow these measures to avoid the danger.

The signal word differentiates between four levels of danger:

- **DANGER**
Immediate danger of severe injury or death
- **WARNING**
Possible danger of severe injury or death
- **CAUTION**
Risk of minor injuries
- **NOTICE**
Risk of extensive material/property damage

Other symbols

These symbols are used in the document and on or in the unit:



Note, e.g. specific instructions regarding efficient and cost-effective use of the unit.



CE labelling



Serial number



Order number



Observe the operating instructions.



Date of manufacture



Dispose of the unit properly and in accordance with applicable national, regional and local laws.



Disconnect all power from the unit.

1.2 Copyright information

All names of circuits, processes, names, software programs and units used in this document are protected by copyright.

The reprinting of the installation and operating instructions, even in extracts, is only permitted with the written permission of Dürr Technik.

2 Safety

Dürr Technik has developed and constructed the units in such a way that danger is to a large extent excluded if the units are used as intended. Nevertheless, residual risks can remain. You should therefore observe the following notes.

2.1 Intended use

The unit is intended for the compression of atmospheric air. It provides oil-free air for a range of applications. The unit has been designed for installation into systems and machines. The device is suitable for IP 67. In application areas that require IP 67, it is necessary to check whether all of the electrical, pneumatic and mechanical connections of the compressor also meet the requirements for IP67 protection.

The operator must ensure that a suitable air intake filter is used for the air intake on the device and that this is protected against excessive soiling and moisture.

When deployed outside, the unit must be protected against mechanical damage and excessive soiling by a housing (e.g. sheet metal casing). The unit must not be taken into operation until the manufacturer of the system has ensured that all requirements relating to safe operation have been met.

Its use in the vicinity of gases or flammable liquids is prohibited.

2.2 Improper use

Any use of this unit / these units above and beyond that described in the Installation and Operating Instructions is deemed to be incorrect usage. The manufacturer cannot be held liable for any damage resulting from incorrect usage. The operator will be held liable and bears all risks.



WARNING
Serious injury and material damage due to improper usage

- › Conveying explosive mixtures in any way other than that specified is not permitted.

2.3 General safety information

- › Always comply with the specifications of all guidelines, laws, and other rules and regulations applicable at the site of operation for the operation of this unit.
- › Check the function and condition of the unit prior to every use.
- › Do not convert or modify the unit.
- › Comply with the specifications of the Installation and Operating Instructions.
- › The Installation and Operating Instructions must be accessible to all operators of the unit at all times.

2.4 Specialist personnel

Operation

Unit operating personnel must ensure safe and correct handling based on their training and knowledge.

- › Instruct or have every user instructed in handling the unit.

Installation and repairs

- › Always arrange for any assembly work, readjustments, alterations, extensions, and repairs to be performed by Dürr Technik or by personnel authorised and trained by Dürr Technik. Qualified personnel are defined as those trained by Dürr Technik; who are familiar with the unit technology; and are aware of the dangers presented by the unit.

2.5 Electrical safety

- › Observe and comply with all the relevant electrical safety regulations when working on the unit.
- › Replace any damaged cables or plugs immediately.

2.6 Only use original parts

- › Only use accessories and special accessories that are specified or approved by Dürr Technik.
- › Only use original working and spare parts.



Dürr Technik accepts no liability for damage resulting from the use of non-approved accessories, special accessories or any working parts or spare parts other than original parts.

2.7 Transportation and storage

The original packaging provides optimum protection for the unit during transport.

 Dürr Technik will not accept any responsibility or liability for damage occurring during transport due to the use of incorrect packaging, even where the unit is still under guarantee.

- Only transport the unit in its original packaging.
- Keep the packing materials out of the reach of children.



NOTICE

Damage to the unit due to incorrect transportation/storage

Incorrect storage and transportation can cause damage to the unit.

- > Protect the unit from moisture during transportation.
- > Transport the unit with the motor base pointing downwards.

The unit may be stored in its original packaging

- in warm, dry and dust-free rooms;
- protected from contaminants.



If possible, retain the packaging material.

Ambient conditions during storage and transport

Ambient conditions during storage and transport

Temperature	°C	-25 to +55
Rel. humidity	%	10 % to 90 %

Please refer to the labels on the packaging padding.

2.8 Disposal

Unit



Dispose of the unit properly and in accordance with applicable national, regional and local laws.

Packaging



Dispose of the packaging material in an environmentally responsible manner.

- Note current disposal routes.
- Keep the packing materials out of the reach of children.



3 Overview

3.1 Scope of delivery

The following items are included in the scope of delivery:

E-Bull 1037100100

Product name	Article number
Compressor unit	1037100100
Including vibration dampers	
Installation and Operating	
Instructions	1037100150



3.2 Spare parts and accessories

The following wearing parts need to be replaced at the specified maintenance intervals (see "9.1 Maintenance schedule").

Spare parts

E-Bull

Air intake filter cartridge

1037100193

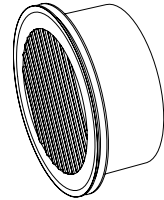

Vibration damper set

1037100191

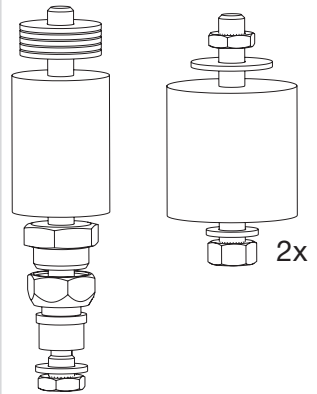

Air intake filter with hose

1037100192

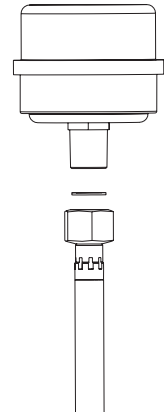



4 Technical data

4.1 Schematic drawing

E-Bull 1037100100

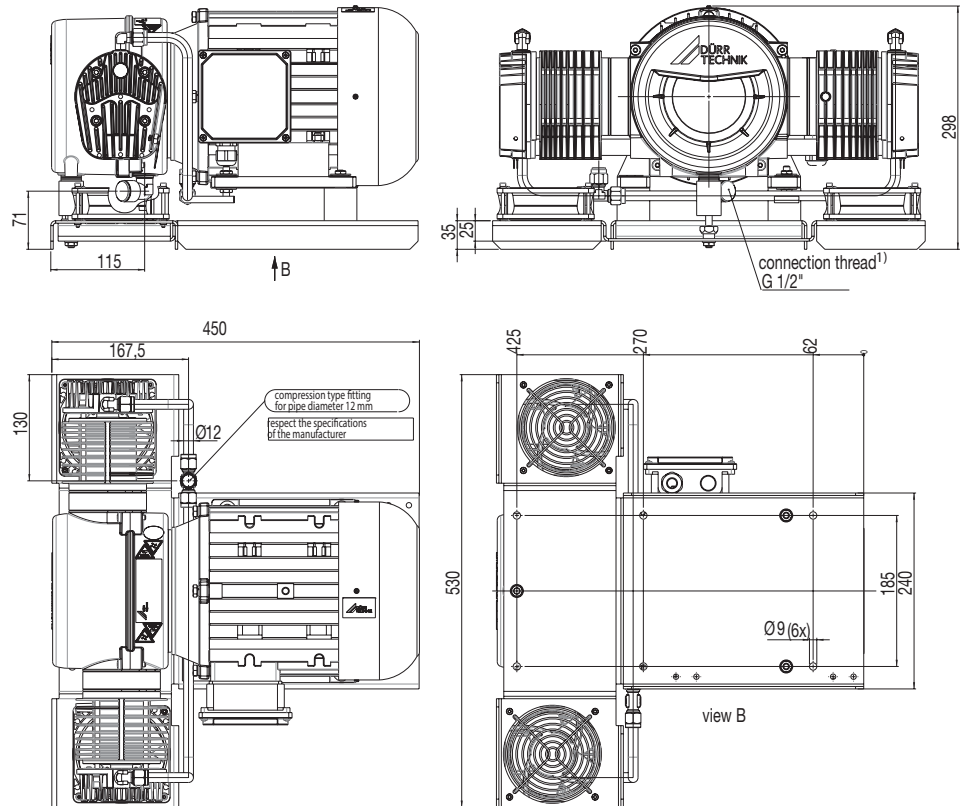

Figure 1: Dimensions 1037100100

¹⁾ inner thread G1/2"

4.2 Technical data

E-Bull 1037100100 - 400 V

Electrical data

Type		E-Bull	
Article no.		1037100100	
Electrical frequency	Hz	50	60
Nominal voltage	V _{AC}	400 3~	400 3~
Rated power	P1 (W)	3400	3950
Nominal current	A	6.9	6.8
Speed	min ⁻¹	1455	1730
Type of protection (motor)	IP	67	67
Duty cycle	%	100	100
Temperature switch (motor)	Bimetal	Yes	Yes
FU capable		Yes	Yes

General technical data

Delivery quantity p _e 0 bar	l/min	420	455
Delivery quantity p _e 5 bar	l/min	340	390
Delivery quantity p _e 10 bar			
Safety pressure PS	l/min	280	315
Nominal pressure	bars	10	10
	bars	12	12
Noise level (at 10 bar)	dB(A)	73	78
Weight	kg	45	45
Dimensions (LxWxH)	mm	450 x 530 x 298	450 x 530 x 298

Ambient conditions during operation

temperature	°C	-40 to +50	-40 to +50
Rel. humidity	%	100	100

E-Bull 1037100100 - 230 V**Electrical data**

Type		E-Bull	
Article no.		1037100100	
Electrical frequency	Hz	50	60
Nominal voltage	V _{AC}	230 3~	230 3~
Rated power	P1 (W)	3400	3950
Nominal current	A	12.0	11.8
Speed	min ⁻¹	1455	1730
Type of protection (motor)	IP	67	67
Duty cycle	%	100	100
Temperature switch (motor)	Bimetal	Yes	Yes
FU capable		Yes	Yes

General technical data

Delivery quantity p _e 0 bar	l/min	420	455
Delivery quantity p _e 5 bar	l/min	340	390
Delivery quantity p _e 10 bar	l/min	280	315
Nominal pressure	bars	10	10
Safety pressure PS	bars	12	12
Noise level (at 10 bar)	dB(A)	73	78
Weight	kg	45	45
Dimensions (LxWxH)	mm	450 x 530 x 298	450 x 530 x 298

Ambient conditions during operation

temperature	°C	-40 to +50	-40 to +50
Rel. humidity	%	100	100

4.3 Declaration of conformity for machines in accordance with the 2006/42/EC Directive

We hereby declare that the unit described below conforms to all requirements of the machine directive 2006/42/EC.

The unit named below fulfills the requirements of the following directives:

- Electromagnetic Compatibility (EMC) Directive 2014/30/EU
- RoHS directive 2011/65/EU

Manufacturer's name:	Dürr Technik GmbH & Co. KG
Manufacturer's address:	Pleidelzheimer Straße 30 D-74321 Bietigheim-Bissingen

Reference number:	E-Bull 1037
Article designation:	Compressor
From serial number / build year:	000000000 / June 2019

We hereby declare that the unit may only be commissioned once it has been established that the machine into which this unit is to be installed complies with the provisions as set out in Machinery Directive 2006/42/EC.

The following harmonised standards and other standards have been applied:

DIN EN 1012-1:2011-02
DIN EN 60034-1:2011-02
DIN EN 60034-5:2007-09
DIN EN 60335-1:2014-11
DIN EN 61000-3-2:2015-03
DIN EN 61000-6-3:2012-11
DIN EN 60204-1:2010-05
DIN EN 50106:2009-05
DIN EN ISO 12100:2013-08

Bietigheim-Bissingen, 20 May 2019

Andreas Ripsam
Executive Board of Dürr Technik

Proof of signature in the
Original document held by Dürr Technik



5 Requirements

5.1 Setup

The room chosen for set up must fulfil the following requirements:

- Well-ventilated room (not made for another purpose such as e.g. a boiler room or wet room)
- When deployed outside, the unit must be installed in a housing to protect it against soiling and mechanical damage (e.g. sheet metal casing).
- The device is suitable for IP 67. In application areas that require IP 67, it is necessary to check whether all of the electrical, pneumatic and mechanical connections of the compressor also meet the requirements for IP67 protection.
- Set up the unit on a clean, level and sufficiently stable surface (take the weight of the unit into account).
- The type plate of the unit must be easily readable (also after installation).
- The unit must be easily accessible for operation and maintenance.
- Maintain sufficient distance (see drawing).

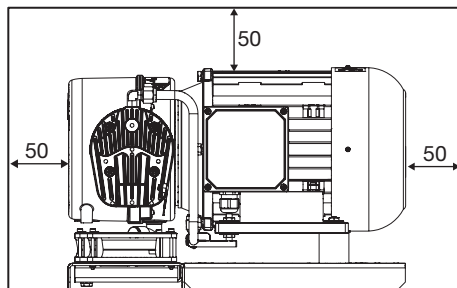
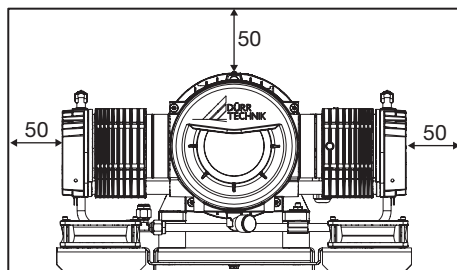

NOTICE

Risk of overheating due to insufficient ventilation

The unit generates heat. Possibility of heat damage and/or reduced service life of the unit.

- › Do not cover the unit.
- › Air must be able to flow in and out unobstructed.
- › Ventilation openings must be sufficiently large.
- › Installed units may require an independent ventilation system in unfavourable cases.

5.2 Vibration dampening

The unit generates vibrations. Suitable vibration dampers must be used to damp these vibrations.



CAUTION

The use of rigid connections may damage the units or the system in which the units have been installed.

- › Do not install rigid connection lines between unit and system.

5.3 Installation position and fastening

Install the units as near as possible to the horizontal. Other fitting positions must be agreed in advance with Dürr Technik.

5.4 Ventilator

When working on the device, the following safety instructions apply for the fans:



DANGER Rotating impeller wheel

There is a risk of injury for any body parts that come into contact with the impeller wheel. Long hair, loose items of clothing and jewellery can all get caught up and be pulled into the product.

- › Never operate the fan without a safety guard.
- › Do not wear any loose items of clothing or jewellery when working on the device.
- › Use a hair net to protect long hair.



WARNING Excessively high loads

- › The product must be immediately taken out of operation if it is subjected to prohibited, excessively high loads (e.g. impact/shock, heat, overvoltage).

6 Electrical installation

6.1 Electrical connection without a mains plug



DANGER Connection to the power supply may only be performed by a qualified electrician.

- › Comply with the regulations from the local power supply companies.
- › Connect the unit to a power supply source with a correctly installed protective earth conductor. (Exception: units with DC permanent-magnet motors.)
- › Before commissioning, verify that the power supply voltage complies with the voltage specifications of the type plate. Ensure that the current circuit on the building side has appropriate fuse protection.

If the unit is permanently connected to the power supply, a cut-off device (e.g. power circuit breaker) with a contact gap of at least 3 mm must be provided in the vicinity of the unit. The disconnecting device must comply with the standard 60204-1:2010-05, 5.3.

Comply with the information provided in the wiring diagrams, label or circuit diagram in the terminal box when making the electrical connection.

6.2 IP protection type



The term "IP protection type" (International Protection) is defined by IEC/EN 60529 "Type of protection by housing (IP Code).



DANGER Comply with the IP protection type for protecting the unit against contact, foreign matter, and moisture

Failure to comply with this information can result in electric shock, personal injury, or material damage.

- › The unit must only be installed or used in accordance with its type of protection.

The owner is responsible for ensuring that the units are only installed or used in accordance with their protection type.

6.3 Fuse protection of the supply current circuit



DANGER
Insufficient fuse protection of the units

Insufficient fuse protection of the units can result in fire, electric shock, personal injury or material damage.

- Protect the supply current circuits at all poles in accordance with the nominal current of the electric motors.
- In the case of unmonitored installations, overcurrent protection in accordance with EN 60204-1:2010-05, 7.2 must be provided.



We recommend the installation of a motor protection circuit breaker. A minimum of one line cable fuse with nominal current + 10% unless specified otherwise.

6.4 Circuit diagrams

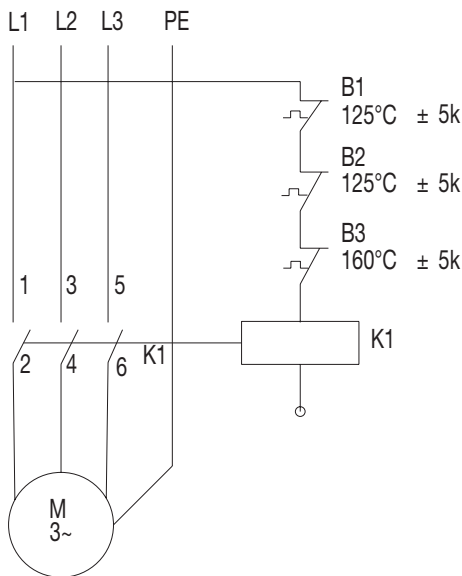

- B1 Cylinder head 1
- B2 Cylinder head 2
- B3 Motor windings
- K1 Thermal switch relay*

* The thermal switch relay is not included in the scope of delivery of the supplied unit, but it needs to be installed on the customer side (see "6.5 Motor protection - temperature").

6.5 Motor protection - temperature

3-phase motors

The electric motor can overheat!

The electrical connection must be performed in accordance with the circuit diagram "6.4 Circuit diagrams".



Units with a temperature switch start again automatically after they have cooled down.



DANGER
The temperature switch may suffer damage from a motor lockage or a short circuit in the motor winding

Insufficient fuse protection of the electric motors can result in fire, electric shock, personal injury or material damage.

- Installation of a circuit breaker.



DANGER
Insufficient fuse protection of the electric motors in unmonitored installations

Insufficient fuse protection of the electric motors can result in fire, electric shock, personal injury or material damage.

- Installation of a circuit breaker.
- The temperature switch must be connected to a suitable relay.

7 Commissioning

7.1 Remove the transport locks

The unit is securely protected with packaging material to ensure safe transportation.

- › Remove the packaging material.
- › Remove the protective film.
- › Check the unit for damage in transit.

7.2 Connect oil-free piston compressor

 Depending on the product, the units are designed for a specific nominal pressure (see "4.2 Technical data").

If this nominal pressure is exceeded, the service life of the product is reduced.

The atmospheric air is drawn in via the air intake filter on the air inlet side. On the air outlet side, the compressed air flows through the air line to the consumer.

Air inlet

The air inlet opening is located on the underside of the crankcase and is closed with a plug on delivery. To maintain the life of the unit, a suitable air intake filter must be installed at the air inlet.

- › Remove the plug from the air inlet opening.

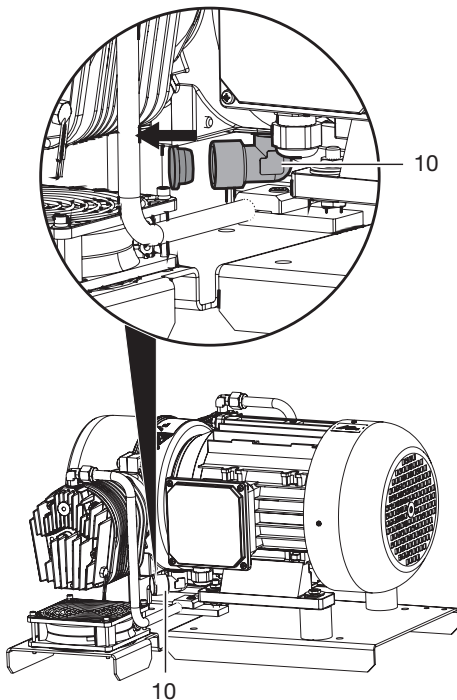

- › Connect the hose connection of the air intake filter to the air inlet opening.

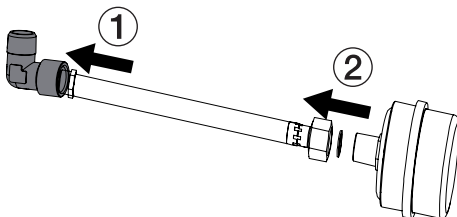

Air outlet

The compressed air outlet is located on the T-piece between the cylinder heads and is sealed with a plug on delivery.

- › Remove the plug from the compressed air outlet.
- › Connect a pressure hose to the external thread M16 x 1.5.

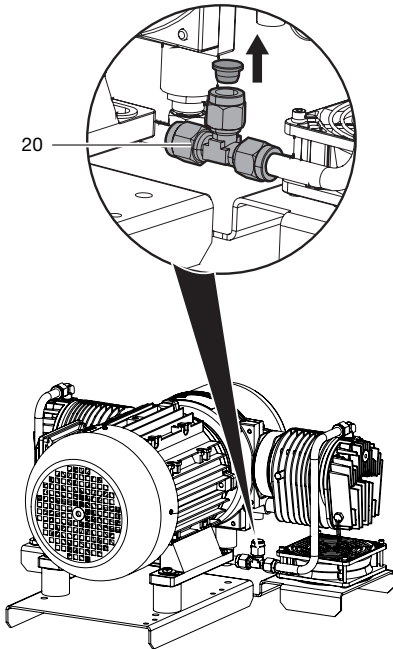

20 Compressed-air outlet

Operating the unit in a system

If the unit is installed in a system, the safety pressure must not be exceeded (see "4 Technical data"). Ensure that the safety pressure does not exceed permissible overpressure values by providing of a safety device (e.g. safety valve, solenoid valve etc.).

The operating or working pressure may not exceed the nominal pressure of the unit. Accessories for pressure control, e.g. pressure switches and pressure reducers, are necessary in order to ensure a constant mains pressure during operation.

Depending on the application, control systems, valve units, containers or other accessories are required for safe operation.



8 Operation



Prior to working on the unit or in case of danger, disconnect it from the mains.



DANGER

Risk of electric shock due to defective cable connections and risk of burns due to hot surfaces if the unit is operated with the cover open.

During operation, the unit is under a live voltage and its surfaces get hot.

- > The cover of the unit must be closed during operation.
- > Regularly check cable connections for damage.

8.1 Switching the unit on/off



NOTICE

Automatic start-up of the unit after cooling down

9 Maintenance



De-energise the unit prior to working on it or in the event of potential danger (e. g. pull the mains plug) and prevent it from being switched back on again.



Repair and maintenance work may only be carried out by qualified specialist personnel.



Purge a unit with a pressure vessel completely.

9.1 Maintenance schedule

Maintenance interval	Maintenance work
Monthly	› Clean the surface of the unit with a non-fuzzing cloth. Keep the crank-case, cylinder heads and fans free of dust and dirt.
Annually	› Replace the air intake filter cartridge. If the ambient air carries a heavy burden of pollution/dirt, we recommend replacement every six months.
4 years or 8000 operating hours	› Replace the vibration dampers.

The maintenance intervals generally depend on the ambient conditions and operating conditions. The maintenance intervals are shortened e.g. if the ambient air carries a heavy burden of pollution/dirt or if operation takes place under ambient temperatures that are outside the stated temperature range (see "4 Technical data").

9.2 Replace the air intake filter cartridge

- › Open the cover of the air intake filter by turning it clockwise.
- › Take out the air intake filter cartridge.

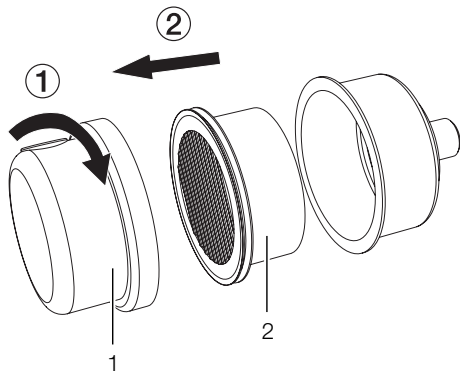

- 1 Air intake filter lid
- 2 Intake filter cartridge

- › Insert a new air intake filter cartridge.
- › Close the cover of the air intake filter by turning it anti-clockwise.

9.3 Replace the vibration dampers

- › Loosen the fastening nuts for the compressor unit / support plate.

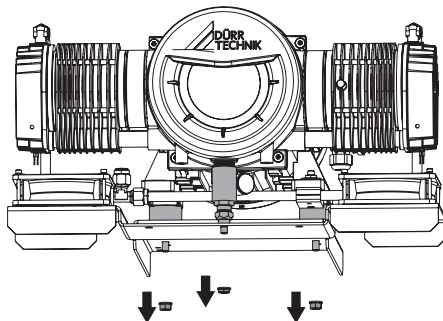

- › Disconnect the cable connections of the fans.
- › Remove the compressor unit from the support plate.

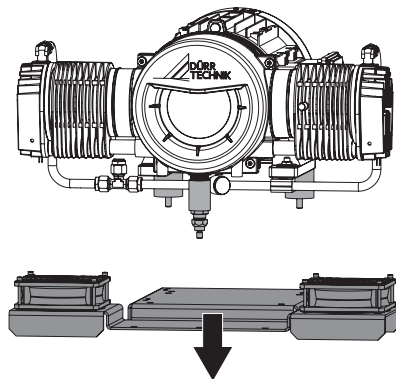

- › Unscrew the vibration dampers from the crankcase.

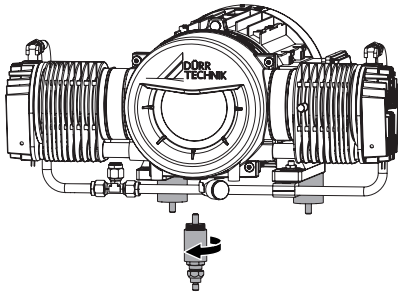

- › Unscrew the vibration dampers from the motor support foot. Loosen the fastening nuts to do this.

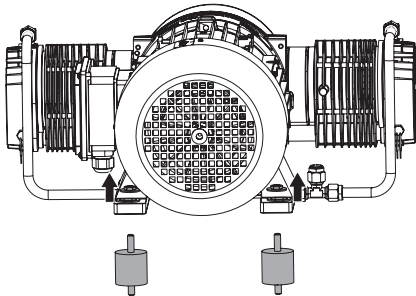

- › Mount new vibration dampers and tighten the fastening nuts to a tightening torque of 10 Nm.

10 Taking out of use

 During shutdown of an installed unit, the operating instructions of the complete system are binding.

- › Switch off the unit.
- › Disconnect the mains plug.



11 Tips for operators and service technicians



Any repairs exceeding routine maintenance may only be carried out by qualified personnel or our service.



De-energise the unit prior to working on it or in the event of potential danger (e. g. pull the mains plug) and prevent it from being switched back on again.

Fault	Probable cause	Solution
Unit does not start	No power supply voltage	› Inform an electrician. Check mains fuse and if possible, switch on unit again.
	Undervoltage or overvoltage	› Inform an electrician. Measure power supply voltage.
	Motor defective	› Replace the unit.
	Temperature switch defective	› Inform an electrician.
Reduction in air flow	Lines, hoses or connections leaking	› Inform a service technician. Check / renew lines, hoses or connections.
	Air intake filter soiled	› Replace the air intake filter at least 1x per year.
Unit too noisy	Bearing damaged	› Inform a service technician.
	Vibrations are being transmitted to the housing	› Use suitable vibration dampers.
	Defective vibration dampers	› Install new vibration dampers.



12 Addresses

12.1 Returns / Repairs

Dürr Technik GmbH & Co. KG
Pleidelsheimer Straße 30
74321 Bietigheim-Bissingen
-Germany-



WARNING

Risk of explosion of the pressure tank and pressure hoses

- › The pressure tank and the pressure hoses must be vented before they are stored or transported.



Use the original packaging when returning units, if possible. Always pack the units in a plastic bag. Use recyclable packing material.

12.2 To order spare parts

Tel. +49 (0) 71 42 / 9022 - 0
Fax +49 (0) 71 42 / 9022 - 99
E-mail: office@duerr-technik.de

The following information is required when ordering spare parts:

Type designation and item number

- Order number as appears on the spare parts list
- Quantity required
- Exact shipping address
- Shipping information

12.3 Service

Tel. +49 (0) 71 42 / 90 22 - 20
Fax +49 (0) 71 42 / 90 22 - 99
E-mail: service@duerr-technik.de

12.4 Addresses worldwide

www.duerr-technik.eu

Dürr Technik GmbH & Co. KG
Pleidelsheimer Strasse 30
74321 Bietigheim-Bissingen
Germany
Fon: +49 7142-90 22 -0
www.duerr-technik.com
office@duerr-technik.de

