

Oil-free compressor station P2B 304M

EN

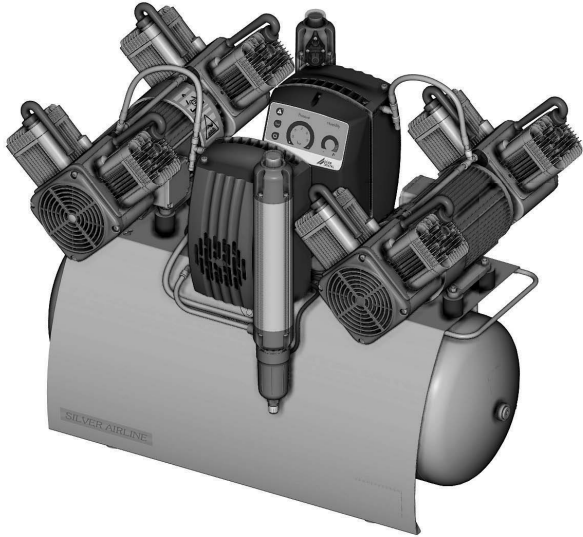

Installation and Operating Instructions

CE

1036100202L02



 **DÜRR
TECHNIK**

1608V003

Contents



Important information

1 About this document	3
1.1 Warnings and symbols	3
1.2 Copyright information	3
2 Safety	4
2.1 Intended use	4
2.2 Improper usage	4
2.3 General safety information	4
2.4 Qualified personnel	4
2.5 Protection from electric shock	4
2.6 Only use genuine parts	4
2.7 Transportation and storage	5
2.8 Disposal	5



Product description

3 Overview	6
3.1 Scope of delivery	6
3.2 Special accessories	6
3.3 Wear parts and spare parts	6
4 Technical data	7
4.1 Declaration of conformity for machines in accordance with the 2006/42/EC Directive	8
4.2 Type plate	9
5 Circuit diagram	10
6 Operation	12
6.1 Operating panel	12
6.2 Tyscor Pulse (optional)	13



Installation

7 Requirements	14
7.1 Installation/setup room	14
7.2 Setup	14
7.3 Information about electrical connections	14
8 Transport	15
9 Installation	15
9.1 Remove the transport locks	15

9.2 Installing the compressor unit	15
9.3 Running two compressors in a single compressed air network (optional)	18
9.4 Establishing the compressed air connection	19
9.5 Pressure reducer	19
9.6 Place a collector tray underneath.	19
9.7 Electrical connections	20

10 Commissioning and first start-up	21
10.1 Checking the switch-on/cut-off pressure	21
10.2 Checking the safety valve	21
10.3 Draining the condensation water	22
10.4 Adjusting the rate of flow at the pressure reducer	22
11 Adjustment options	23
11.1 Adjustment of the switch-on/cut off pressure	23

12 Monitoring the device with Tyscor Pulse	23
12.1 Add device	23
12.2 Adding the device in the cockpit	24
12.3 Adjustment of the switch-on/cut off pressure	24
12.4 Manually starting the device	25
12.5 Transferring the maintenance schedule to the software	25



Operation

13 Operation	26
13.1 Operating panel	26
13.2 Switching the unit on/off	27
13.3 Normal operation	27
13.4 Standby mode	27
13.5 Auxiliary operation	27
13.6 Set-up mode	27
13.7 Emergency mode	28
14 Monitoring the device with Tyscor Pulse	28
14.1 Monitoring operation	28
14.2 Completing the task	29
14.3 Creating a report	29

15 Maintenance 30

 15.1 Maintenance schedule 30

 15.2 Changing the filter 31

16 Taking out of use 32

 16.1 Taking the unit out of use 32

 16.2 Storage of the unit 33

EN



Troubleshooting

17 Tips for operators 34

18 Tips for service technicians 36



Addresses



Important information

1 About this document

These installation and operating instructions represent a part of the unit. They correspond to the relevant version of the unit and the status of technology valid at the time of its market launch.



In the event that the instructions and notes in these installation and operating instructions for are not observed, Dürr Technik accepts no warranty or liability of any kind for the safe operation and reliable function of the units.

This translation was prepared to the best of our knowledge. The original German language version of the manual is the definitive version. Dürr Technik is not liable for translation errors.

1.1 Warnings and symbols

Warnings

The warnings in this document are intended to draw your attention to possible injury to persons or damage to machinery.

The following warning symbols are used:



General warning symbol



Warning – dangerous high voltage



Warning – hot surfaces



Warning - automatic start-up of the unit

The warnings are structured as follows:



SIGNAL WORD

Description of the type and source of danger

Here you will find the possible consequences of ignoring the warning

- Follow these measures to avoid the danger.

The signal word differentiates between four levels of danger:

- **DANGER**
Immediate danger of severe injury or death
- **WARNING**
Possible danger of severe injury or death
- **CAUTION**
Risk of minor injuries
- **NOTICE**
Risk of extensive material/property damage

Other symbols

These symbols are used in the document and on or in the unit:



Note, e.g. specific instructions regarding efficient and cost-effective use of the unit.



Take note of the accompanying documents.



CE labelling



Manufacturer



Order number



Serial number



Dispose of the unit properly and in accordance with applicable national, regional and local laws.



Air



Switch off and de-energise the device (e. g. unplug from mains).

1.2 Copyright information

All names of circuits, processes, names, software programs and units used in this document are protected by copyright.

The reprinting of the installation and operating instructions, even in extracts, is only permitted with the written permission of Dürr Technik.

2 Safety

Dürr Technik has developed and constructed the units in such a way that danger is to a large extent excluded if the units are used as intended. Nevertheless, residual risks can remain. You should therefore observe the following notes.

2.1 Intended use

The unit is intended for the compression of atmospheric air. The unit has been designed for operation in dry, ventilated rooms. The unit must not be operated in a damp or wet environment. Its use in the vicinity of gases or flammable liquids is prohibited. Only operate the mobile units in an upright position.

2.2 Improper usage

Any other usage or usage beyond this scope is deemed to be improper. The manufacturer accepts no liability for damage resulting from such use. In such cases, the user/operator will bear the sole risk.



WARNING

Serious injury and material damage due to improper usage

- › Conveying explosive mixtures in any way other than that specified is not permitted.

2.3 General safety information

- › When operating this unit, always observe all directives, laws, and other rules and regulations applicable at the site of operation.
- › Check the function and state of the unit prior to each use.
- › Do not convert or modify the unit.
- › Comply with the specifications of the Installation and Operating Instructions.
- › Ensure that the unit operator has access to the Installation and Operating Instructions at all times.

2.4 Qualified personnel

Operation

Unit operators must ensure safe and correct handling based on their training and knowledge.

- › Instruct or have every operator instructed in the handling of the unit.

Installation and repairs

- › Always arrange for any assembly work, readjustments, alterations, extensions, and repairs to be performed by Dürr Technik or by personnel authorised and trained by Dürr Technik. Qualified personnel are defined as those trained by Dürr Technik; who are familiar with the unit technology; and are aware of the dangers presented by the unit.

2.5 Protection from electric shock

- › When working on the units observe all the relevant electrical safety regulations.
- › Immediately replace any damaged cables or plugs.

2.6 Only use genuine parts

- › Only use accessories and special accessories that are specified or approved by Dürr Technik.
- › Only use original working and spare parts.



Dürr Technik accepts no liability for damage resulting from the use of non-approved accessories, special accessories or any working parts or spare parts other than original parts.

2.7 Transportation and storage

The unit is delivered in a cardboard box filled with packing material. The original packaging provides optimum protection for the unit during transport. Wherever possible, always use the original packaging for transport and storage of the unit.

- Keep the packing materials out of the reach of children.



WARNING

Risk of explosion of the pressure vessel and pressure hoses

- › The pressure vessel and the pressure hoses must be vented before they are stored or transported.
- › Protect the unit from moisture during transportation.
- › Always transport the unit in an upright position.
- › Only transport the unit using the transport handles provided.
- › Do not transport the unit by the air intake filter.

The unit may be stored in its original packaging

- in warm, dry and dust-free rooms;
- protected from contaminants.



If possible, retain the packaging material.

2.8 Disposal

Unit



Dispose of the unit properly and in accordance with applicable national, regional and local laws.

Packaging



Dispose of the packaging material in an environmentally responsible manner.

- Note current disposal routes.
- Keep the packing materials out of the reach of children.



3 Overview

3.1 Scope of delivery

The following items are included in the scope of delivery (possible variations due to country-specific requirements and/or import regulations):

Product name Article number

Oil-free 400 V compressor station P2B 304M. 1036100200

- Pressure vessel
- Compressor
- Connection parts
- Vibration damper
- Collector tray for membrane drying unit
- "Tyscor Pulse" software
- Network cable, 3 m
- Installation and Operating Instructions
- Unit log book

3.2 Special accessories

The following optional items can be used with the device:

Pressure reducer. 6040-992-00

Fine filter cartridge 3 µm 1610-121-00

Network cable, 3 m. 9000-119-071

Tyscor Pulse 0949-150-00

3.3 Wear parts and spare parts

The following working parts need to be changed at regular intervals (refer to the "Maintenance" section):

Product name Article number

Air intake filter 0832-982-00

Fine filter cartridge 0.01 µm 9000-416-0035ET

Sintered filter. 1650-101-00

Vibration damper set. 0881-991-00

 Any repairs above and beyond routine maintenance must only be carried out by suitably qualified personnel or by one of our service technicians.

 If the mains cable of this unit is damaged it must only be replaced by an original mains cable from the manufacturer.

4 Technical data

Electrical data		1036100200	
Electrical frequency	Hz	50	60
Voltage	V	400	400
Rated power	kW	4.4	5.9
Nominal current at 8 bar (0.8 MPa)	A	8.8	9.6
Motor protection switch, recommended setting	A		
Speed	min ⁻¹	1440	1700
Type of protection	IP	IP 21	IP 21
Mains fusing	A	16 **	16 **

** Circuit breaker fuse characteristics B, C or D in accordance with DIN EN 60898

General technical data			
Pressure vessel volume	l	90	90
Delivery at 5 bar (0.5 MPa)	l/min	430	480
Pressure build-up phase 0 - 7.5 bar (0 - 0.75 MPa) approx.	s	77	77
Duty cycle	%	100	100
Initial pressure/Cut off pressure	bar (MPa)	6.5 / 8.5 (0.65 / 0.85)	6.5 / 8.5 (0.65 / 0.85)
Safety valve, maximum permissible operating pressure	bar (MPa)	10 (1)	10 (1)
Pressure dew point at 7 bar (0.7 MPa)	°C	≤ +5	≤ +5
Dimensions (LxWxH)	cm	102 x 62 x 82	102 x 62 x 82
Weight	kg	143	143
Noise level	dB(A)	74	77

Filter mesh size		
Compressor air intake filter	µm	3
Fine filter cartridge 3 µm for membrane-drying unit	µm	3
Fine filter cartridge 0.01 µm for membrane-drying unit	µm	0.01
Sintered filter for membrane drying unit	µm	35

Ambient conditions during storage and transport		
Temperature	°C	-10 to +55
Relative humidity	%	max. 95

Ambient conditions during operation		
Temperature	°C	+10 to +40
Ideal temperature	°C	+10 to +25
Relative humidity	%	max. 95

4.1 Declaration of conformity for machines in accordance with the 2006/42/EC Directive

We hereby declare that the unit described below conforms to all requirements of the machine directive 2006/42/EC.

The unit named below fulfills the requirements of the following directives:

- Electromagnetic Compatibility (EMC) Directive 2014/30/EC
- Low voltage directive 2014/35/EC
- Simple pressure vessel directive 2014/29/EC
- The assembly contains a pressure units covered by directive 2014/68/EC in its current version.
- RoHS directive 2011/65/EU

Manufacturer's name:	Dürr Technik GmbH & Co. KG
Manufacturer's address:	Pleidelsheimer Straße 30 D-74321 Bietigheim-Bissingen

Reference number:	1036
Article designation:	Oil-free compressor station P2B 304M
From the serial number:	H400000

We hereby declare that the unit may only be commissioned once it has been established that the machine into which this unit is to be installed complies with the provisions as set out in Machinery Directive 2006/42/EC.

Bietigheim-Bissingen, 20/04/2016

Andreas Ripsam
Executive Board of Dürr Technik

Proof of signature in the
Original document held by Dürr Technik



4.2 Type plate

Complete system

The type plate for the complete system is located on the pressure vessel of the unit.

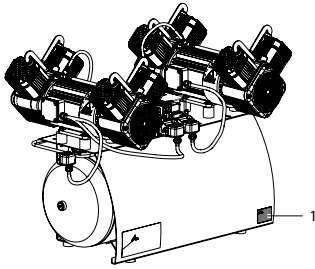

1 Type plate for the complete system

Compressor unit

The type plate of the compressor unit is located on the crankcase below the cylinder.

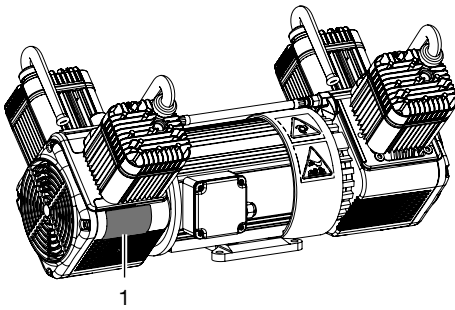

1 Compressor unit type plate

Membrane drying unit

The type plate of the membrane drying unit is located on the side of the membrane drying unit.

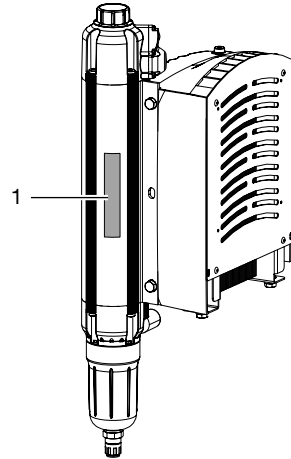

1 Membrane drying unit type plate

5 Circuit diagram

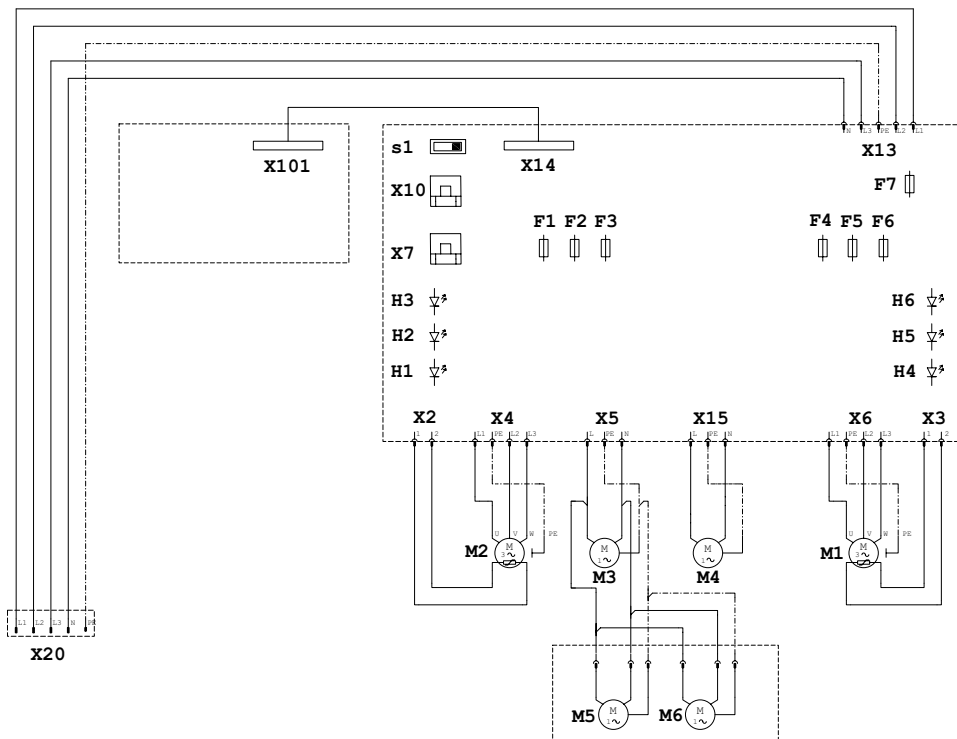

F1 - F6 Fuse T10AH

F7 Fuse T1.6AH

H1 - H3 Status indicator LEDs for temperature sensor, compressor 2

H4 - H6 Status indicator LEDs for temperature sensor, compressor 1

M1 Compressor 1

M2 Compressor 2

M3 Cooling fan motor, membrane drying unit 1

M4 Cooling fan motor, membrane drying unit 2 (Quattro Tandem only)

M5 - M6 Fan motor, compressor cabinet (Duo Tandem only)

S1 Switch, main controller/auxiliary controller

X2 Temperature sensor, compressor 2

X3 Temperature sensor, compressor 1

X4 Connection, compressor 2

X5 Connection, cooling fan motor, membrane drying unit 1

X6 Connection, compressor 1

X7 Network connection

X10 Network connection for connection to main controller/auxiliary controller

X13 Mains connection

X14 Operating panel connection on the control board

X15 Connection, cooling fan motor, membrane drying unit 2 (Quattro Tandem only)

X20 Mains connection 3/N/PE AC 400 V, 50 Hz - 60 Hz

X101 Connection, operating panel



P2B 304M 1036100200 has the identical design as the Quattro Tandem

6 Operation

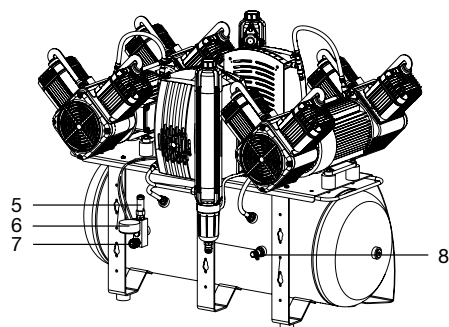
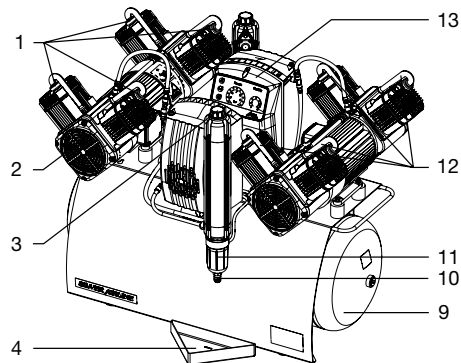

- 1 Air intake filter
- 2 Compressor unit
- 3 Fine filter cartridge 3 µm / 0.01 µm membrane-drying unit
- 4 Collector tray
- 5 Safety valve
- 6 Pressure gauge / display
- 7 Compressed air connection (quick release coupling)
- 8 Condensate drain valve
- 9 Pressure vessel
- 10 Automatic/manual condensate drain valve, membrane drying unit
- 11 Sintered filter for membrane drying unit
- 12 Intake connector
- 13 Controller

The compressor unit draws in atmospheric air and compresses it without oil. It then transports the oil-free compressed air to the membrane drying unit. The cooler and the membrane dryer extract moisture from the compressed air. The

oil-free, hygienic and dry air is stored in the pressure tank ready for use in connected devices.

All of the measurement data for the unit comes together in the control (e.g. pressure in the pressure tank, temperature of the motor windings), where it is then evaluated. Likewise, various settings (e.g. switch on/cut off pressure) can be adjusted, or the unit can be connected via the network to Tyscor Pulse.

6.1 Operating panel

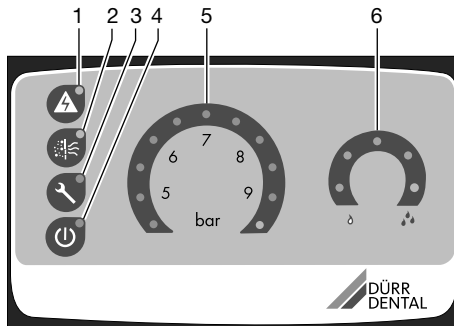

- 1 Fault button with orange LED
- 2 Filter change button with orange LED
- 3 Service key with blue LED
- 4 Standby button with blue LED
- 5 Pressure range display/adjustment
- 6 Pressure dew point display

Different messages and the status of the unit are displayed on the operating panel. In addition, different functions can be started via the buttons.

6.2 Tyscor Pulse (optional)

The unit can be connected to a computer or network with the Tyscor Pulse software (developed by Dürr Dental). Tyscor Pulse displays the current state of the unit as well as messages and malfunctions.

All messages are logged and can be printed or sent.

Regular maintenance and upkeep is implemented in the tasks. Reminders signal when a task is due.

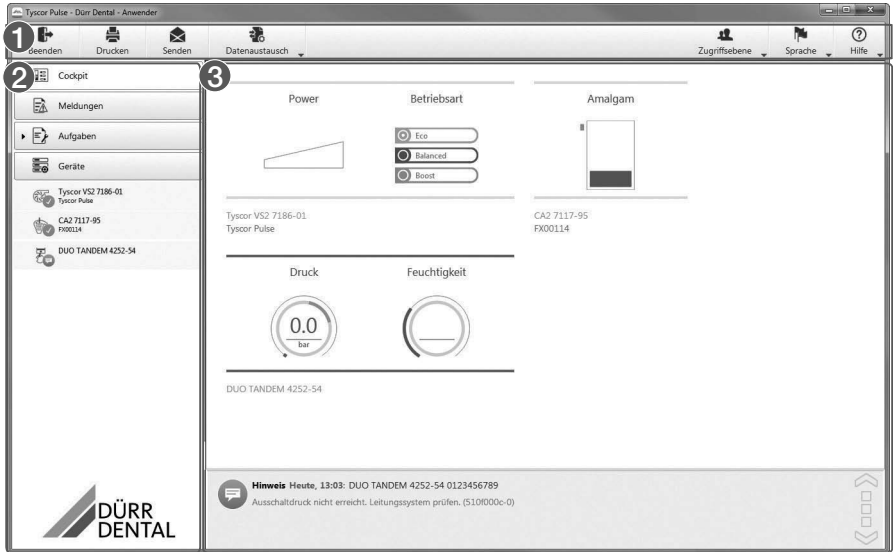

The **cockpit** shows the devices with the current characteristic data and provides a quick overview of the functional status of the devices.

The software interface consists of the menu bar, the side bar and the contents area.



- 1 Menu bar
- 2 Side bar
- 3 Contents area

The contents area depends on the tab selected on the side bar. The current messages are always displayed in the lower part of the contents area.

If there are several current messages, then the mouse wheel or the  or  buttons can be used to scroll through the messages.

 The views and rights depend on the selected access level (Operator, Administrator or Service Technician).

While the software is running (even if the software window is closed), the access level is visible in the task bar (or Mac OS menu bar). The symbol shows the current status of the devices (see "14.1 Monitoring operation"). If a new message appears, a speech bubble tip also appears.



7 Requirements

7.1 Installation/setup room

The room chosen for set up must fulfil the following requirements:

- Closed, dry, well-ventilated room
- Should not be a room made for another purpose (e. g. boiler room or wet cell)



NOTICE

Risk of overheating due to insufficient ventilation

The units generates heat. Possibility of heat damage and/or reduced service life of the unit.

- › Do not cover the unit.
- › Install a fan for auxiliary ventilation in rooms where ambient temperatures exceed ≥ 40 °C while the unit is in operation.

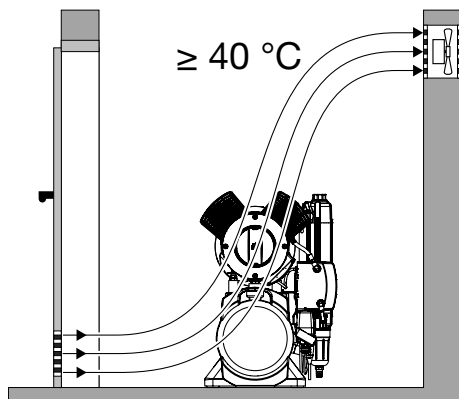

7.2 Setup

The following conditions must be taken into account for installation:



The air is filtered when it is sucked in.

This does not alter the composition of the air. For this reason it is important to keep the sucked-in air free of harmful substances (e.g. do not suck in exhaust gases or contaminated exhaust air).

- Clean, level and sufficiently stable subsurface (note the weight of the unit).
- Type plate easy to read.
- Unit easy to access for operation and maintenance.
- Easy-to-access power outlet to which the unit is connected.
- Maintain sufficient distance to the wall (at least 20 cm).
- The compressed air pipe should be routed as closely as possible to the place of installation (note the length of the hose supplied).

7.3 Information about electrical connections

- › Ensure that the connection to the mains power supply is established in accordance with current valid national and local regulations and standards governing the installation of low voltage units.
- › Observe the current consumption of the unit to be connected.

8 Transport



WARNING

Risk of explosion of the pressure tank and pressure hoses

- › The pressure tank and the pressure hoses must be vented before they are stored or transported.
- › Protect the unit against moisture, dirt and extreme temperatures during transport ("4 Technical data").
- › Always make sure that the condensate collector chamber is empty before transporting the unit ("16 Taking out of use").
- › Always transport the unit in an upright position.
- › Only transport the unit using the transport handles provided.
- › Check the unit for transport damage.

9 Installation

9.1 Remove the transport locks

The unit is securely protected with two foam blocks and a retaining strap for safe transport.

- › Cut and remove the retaining strap.
- › Remove the foam blocks.
- › Check the unit for damage in transit.

9.2 Installing the compressor unit

For weight reasons the unit is not supplied fully assembled. Instead, the compressor units are installed at the site of use.

- › Set up the pressure vessel at the planned installation site.
- › Screw in the vibration dampers into the motor mounting. Comply with the tightening torque (see table).

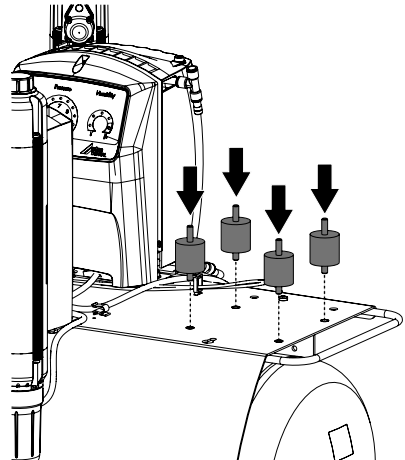

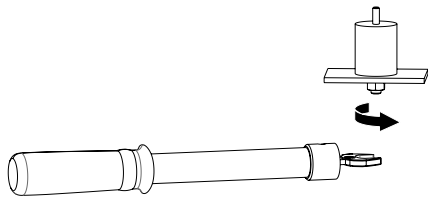

Hexagonal nut dimensions	Width across flats	Tightening torque
M4	AD 7	3 Nm
M5	SW 8	6 Nm
M6	AF 10	9 Nm
M8	AF 13	20 Nm

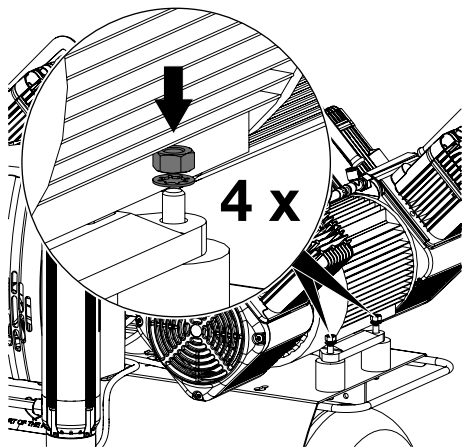

› Connect the compressor unit with the membrane drying unit via the pressure hose.

› Place the compressors on the vibration dampers.

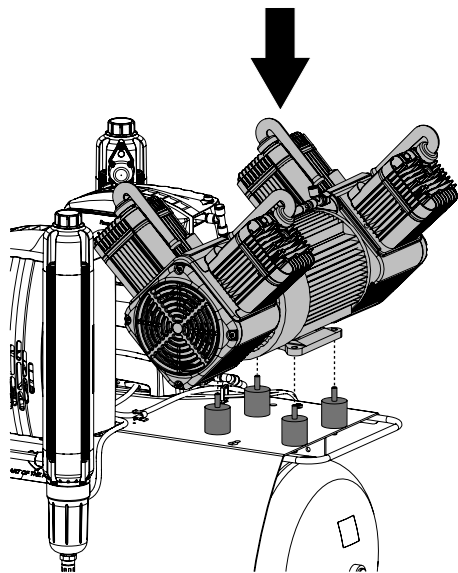

› Attach the compressor unit with the lock washers and nuts.

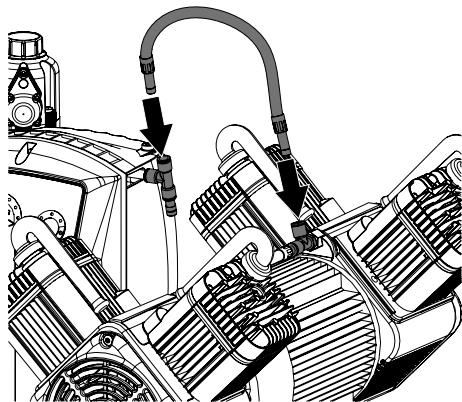

⚠ Warning – dangerous high voltage

› The mains plug must not be plugged in. If it is plugged in, unplug it.

⚠ **NOTICE**
Rotation of the vibration dampers causes increased wear.

The service life of the vibration dampers is reduced.

› When tightening the screws, ensure that the rubber of the vibration dampers does not become twisted.

- › Unscrew the fixing screws of the cover for the control.

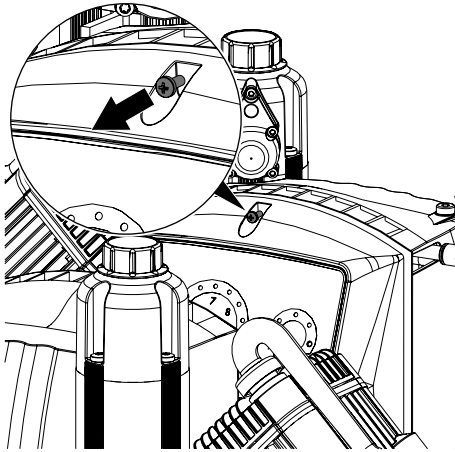
**NOTICE**

The operating panel cable is very short and can damage the PCB when the cover is removed.

- › Carefully remove the cover of the control.
- › Unplug the operating panel cable.
- › Guide the cables of the compressors through the tension relief and fasten.

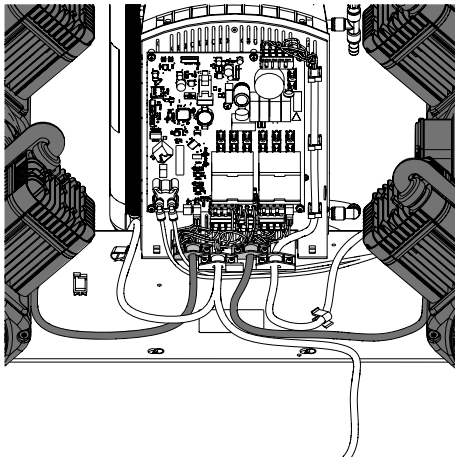

- › Plug the temperature sensor connector and the compressor power supply into the intended bushings.

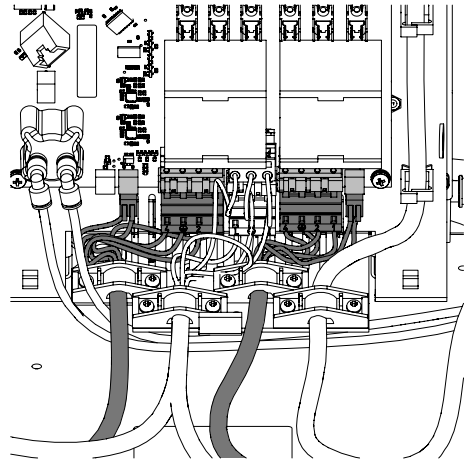
**Connecting the network cable for Tyscor Pulse**

A network connection is only required when using Tyscor Pulse software.

- › Connect the network cable to the network socket (see "5 Circuit diagram").

Installation of the cover

- › Connect the operating panel cable again.
- › Attach the cover of the control again and fasten it with the screw.

**DANGER**

Risk of electric shock due to defective mains cable

- › Mains cables must not be allowed to come into contact with any hot surfaces on the unit.
- › Attach the cables using the cable clips.

9.3 Running two compressors in a single compressed air network (optional)

The two electronic controllers of the compressors are connected to each other via a network cable.

i When routing the cables, maintain the correct gaps between control cables and supply cables.

- › Connect the network cable to the network socket X10.
- › Guide the cable through the cable holder and the tension relief and secure it.
- › Working in the controller of the compressor to be operated as the primary compressor, check whether the switch S1 is in the right-hand position. If it is not, move it to the right (main control).

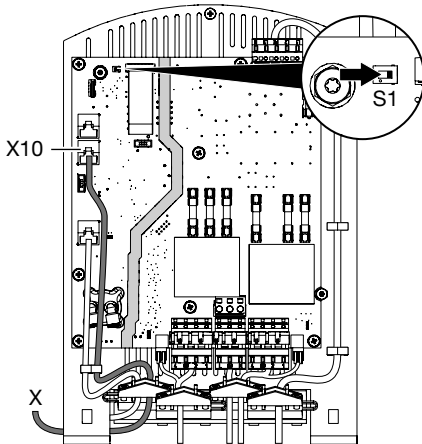

Figure 1: Main controller

- › Working in controller of the compressor to be operated as the secondary compressor, move the switch S1 to the left-hand position (auxiliary control).

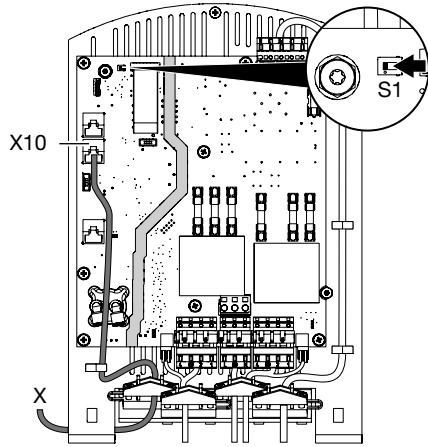

Figure 2: Auxiliary controller

The device is operated via the operating panel of the main control. The auxiliary control is inactive (standby button flashing) and cannot be operated.

Connecting the network cable for Tyscor Pulse

i A network connection is only required when using Tyscor Pulse software.

- › Connect the network cable to the network socket (see "5 Circuit diagram").

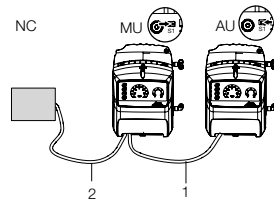

- NC Network socket
- MU Compressor (main controller)
- AU Compressor (auxiliary controller)
- 1 Network cable, connection controller
- 2 Network cable connection to the network socket

Installation of the cover

- › Connect the operating panel cable again.
- › Attach the cover of the control again and fasten it with the screw.



DANGER

Risk of electric shock due to defective mains cable

- › Mains cables must not be allowed to come into contact with any hot surfaces on the unit.
- › Attach the cables using the cable clips.

9.4 Establishing the compressed air connection



The supplied flexible pressure hose between the pipe system and the compressor prevents vibrations from being transmitted and thus reduces noise. This ensures safe and reliable operation.

- › Connect the premounted connecting sleeve on the pressure hose to the quick release coupling of the distributor block.

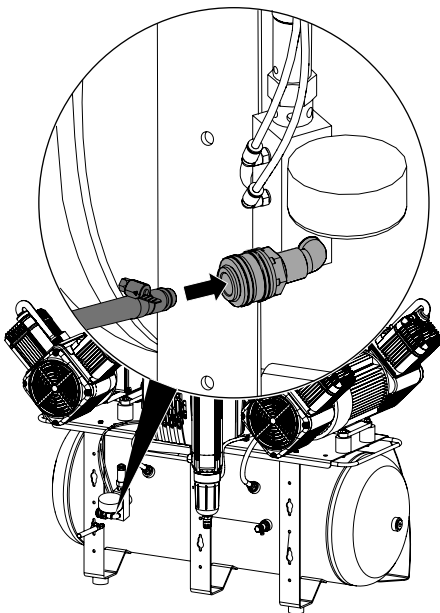

- › Measure the required length of pressure hose and shorten the pressure hose if necessary.
- › Slide the second hose nozzle in place and secure with a hose clip.
- › Connect the connecting sleeve on the pressure hose to the piping system.

9.5 Pressure reducer

- › Insert the pressure reducer into the quick release coupling.
- › Insert the pressure hose into the quick release coupling on the pressure reducer.

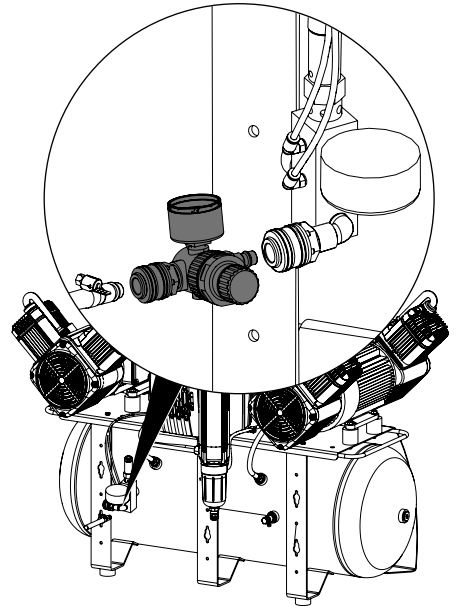

9.6 Place a collector tray underneath

During operation, condensed water is continuously collected in the membrane drying unit and drained off automatically. In order to prevent water damage due to drained condensation water, it is collected in the collector tray.



As an option, the condensed water can be removed via a hose that is connected to the waste water system.

- › Place a collector tray under every membrane drying unit.

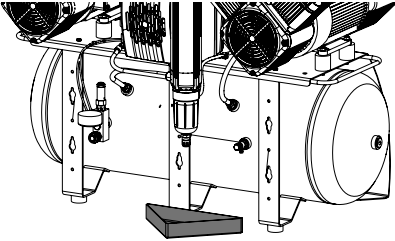
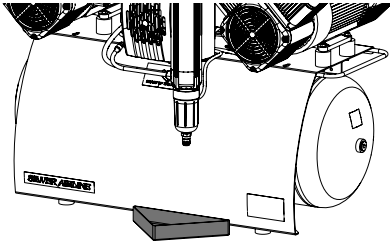

9.7 Electrical connections

Tyscor Pulse (optional)

 During initial installation, we recommend a router or server with DHCP so that the unit is detected in the network.

- › Plug the network cable into the control and into a network socket.
- › Connect to the computer network with the network cable.

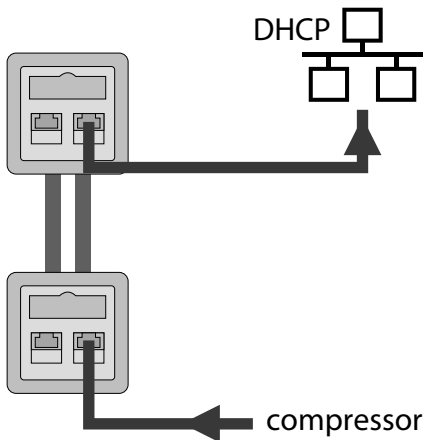

Electrical safety when making connections

 The unit has no main power switch. For this reason it is important that the unit is set up in such a way that the plug can be easily accessed and unplugged if required.

- › The unit must only be connected to a correctly installed power outlet.
- › Make sure that none of the electrical cables leading to the unit are under any mechanical tension.
- › Before initial start-up check that the mains supply voltage and the voltage stated on the type plate match (see also "4. Technical data").

Establishing the electrical connections

 **DANGER**
Risk of electric shock due to defective mains cable

- › Mains cables must not be allowed to come into contact with any hot surfaces on the unit.
- › Connect the mains plug to an earthed socket outlet.
The unit will start immediately after connection of the mains plug.
- › Check whether the socket outlet is switched via the main power switch.
This ensures automatic start-up of the unit after routine activation / deactivation of the main power switch.

10 Commissioning and first start-up

10.1 Checking the switch-on/cut-off pressure

The switch-on/cut-off pressure is preset at the factory. Check the adjustment during first start-up.

When the mains plug is connected the compressor will start after a short delay.

- › Read off the cut-off pressure from the pressure gauge.
- › Drain the air from the pressure tank (e.g. via the condensate drain valve) until the unit starts and then close it again.
- › Read off the pressure when the unit starts up.

If the readings deviate from the values preset at the factory, adjust the values to the factory settings. If other pressure values are required, take care to observe the maximum pressure difference.

10.2 Checking the safety valve

The safety valve must be checked to establish that it is working correctly when the unit is started up for the first time.

-  At the factory, the safety valve is set to 10 bar (1 hPa), checked and stamped.

 **DANGER**
Risk of explosion of the pressure tank and pressure hoses

- › Do not change the safety valve settings.
- › Fill the pressure tank to the cut-off pressure.

 **WARNING**
Risk of damage to the safety valve

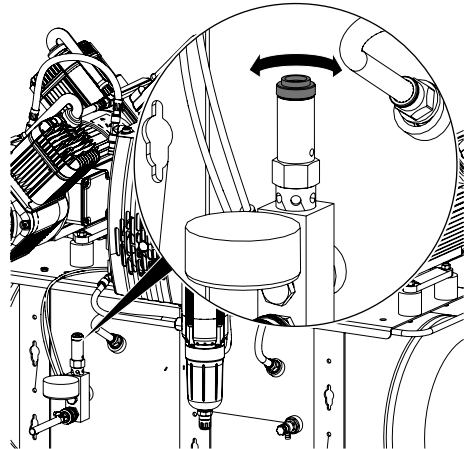

- Risk of explosion of the pressure tank and pressure hoses due to a defective safety valve
- › Do not use the safety valve to vent the pressure tank.

- › When the cut off pressure is reached, turn the screw of the safety valve several turns anti-clockwise until the valve begins to blow. Only allow the safety valve to blow for a short period.



- › Turn the screw clockwise as far as it will go. The valve must now be closed again.

Checking the safety valve – alternative method:

-  With this function the safety valve will open suddenly and emit a very loud blow-off noise
- › Service key:  Keep pressed until the safety valve triggers.
The compressor units keep running as long as the button is pressed. The defined cut off pressure is not taken into account.

10.3 Draining the condensation water

During transport, condensation water can accumulate in the pressure tank due to changes in temperature.

This also applies to compressors with a membrane drying unit.

- › At maximum tank pressure, open the condensate drain valve.

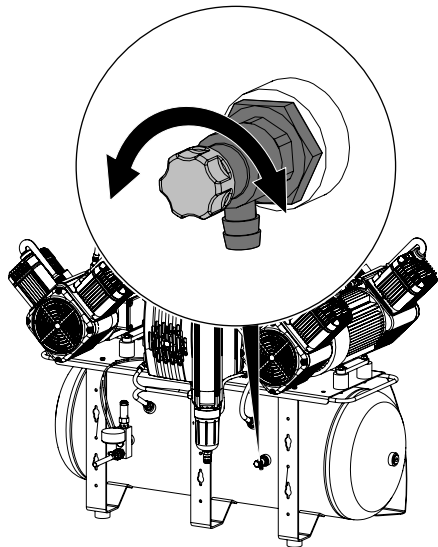

- › Close the condensate drain valve as soon as all of the condensation water has been blown out.

10.4 Adjusting the rate of flow at the pressure reducer

The pressure reducer regulates the rate of flow in the system and adjusts it to the required operating pressure. In order to adjust the rate of flow air needs to be extracted via a consumer.

- › Activate the air consumer unit.
- › Lift the rotary knob at the pressure reducer.
- › Adjust the rate of flow via the rotary knob. Turn the knob in the "+" direction to increase the rate of flow. Turn the knob in the "-" direction to reduce the rate of flow.
- › Press in the rotary knob until it engages and cannot be adjusted.

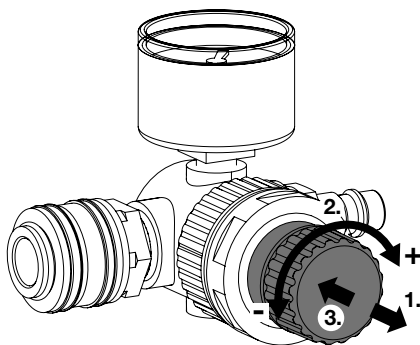

11 Adjustment options

11.1 Adjustment of the switch-on/ cut off pressure



WARNING

Risk of explosion of the pressure vessel

The pressure vessels used in the compressors are designed to withstand continuous pressure changes of 2 bar and can be used continuously under these pressure changes.

- › For load changes > 2 bar (max. permissible: 3 bar), comply with the maximum load change cycles specified in the operating instructions of the pressure vessel.

The pressure adjustment is performed in standby mode.

- › Standby button:  press for at least 2 seconds.
- › Service key:  press for at least 2 seconds.

The blue LEDs in the operating panel flash. They are touch-sensitive and can be adjusted accordingly.

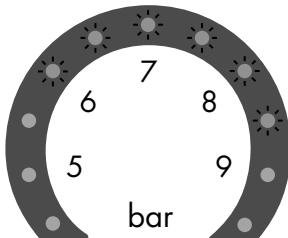

The pressure adjustment is performed in 0.5 bar increments by touching the LED.

- › Touch the first flashing LED with your finger and swipe to the required **switch on pressure**.
- › Touch the last flashing LED with your finger and swipe to the required **cut off pressure**.
- › Use the service key to  confirm.



If no touch pulse is received for 30 seconds, the system will automatically switch to standby operation. The settings are not saved.

12 Monitoring the device with Tyscor Pulse



Weitere Informationen zu Tyscor Pulse finden sie in der Software-Hilfe und im Tyscor Pulse Handbuch Best.-Nr. A949100001.

The following requirements must be met in order to monitor the unit with the software on the computer:

- Unit connected to the network
- Tyscor Pulse (version 3.1 or higher) installed on computer

12.1 Add device

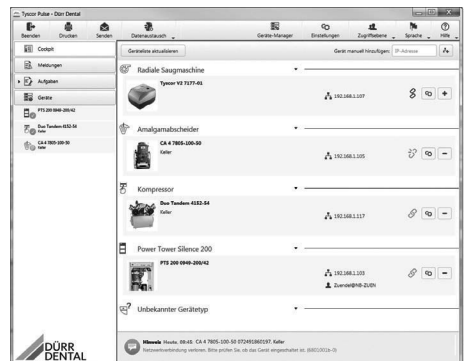

Requirements:

- Unit is switched on and connected to the network
- Administrator or service technician access level selected in the software
- › Working in the menu bar, click on  **Device Manager**.

The list of units appears. A symbol displays the connection status to the software:



The unit is present in the network and connected to the software.



The unit is present in the network but not connected to the software.



The network connection between the software and the unit has been interrupted, e.g. the device is switched off.

The new unit that is not yet connected, is displayed with the connection status .

- › Select the unit and click on . The unit appears in the side bar.

12.2 Adding the device in the cockpit

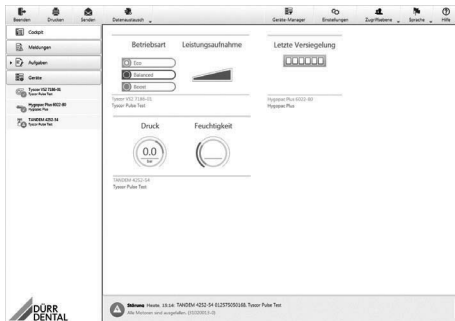

All devices that are connected to the software can be added to the cockpit. When the unit is first connected to the software, the unit is automatically added to the cockpit.

Requirements:

- Administrator or Service Technician access level selected.
- › Click on the device in the device list with the left mouse button and keep the mouse button pressed.
- › With the mouse key pressed, drag the unit onto the cockpit.
- › Release the mouse key.

The block with the current characteristic data and the name of the device appear in the cockpit.

- › To change the position of the device block, click on the block and, with the mouse key pressed, drag it to the required location.

12.3 Adjustment of the switch-on/ cut off pressure



WARNING

Risk of explosion of the pressure vessel

The pressure vessels used in the compressors are designed to withstand continuous pressure changes of 2 bar and can be used continuously under these pressure changes.

- › For load changes > 2 bar (max. permissible: 3 bar), comply with the maximum load change cycles specified in the operating instructions of the pressure vessel.



With the aid of Tyscor Pulse the pressure of the compressor can be adjusted as required.

Requirements:

- Administrator or Service Technician access level selected.
- › Select the device in the list of devices. The block with the current button parameters and the name of the device appear in the Contents area.
- › Use the "+" and "-" buttons to adjust the pressure in increments of 1 bar. If other pressure values are required, it is also possible to enter the value directly in the corresponding fields.

12.4 Manually starting the device



The compressor can be manually started with the aid of Tyscor Pulse.

Requirements:

- Administrator or Service Technician access level selected.
- › Select the device in the list of devices.

The block with the current button parameters and the name of the device appear in the Contents area.
- › Use the mouse to click the **Start** button next to Compressor Test.

The compressor unit will continue to run for as long as the mouse button is pressed.
- › Release the mouse button.

12.5 Transferring the maintenance schedule to the software

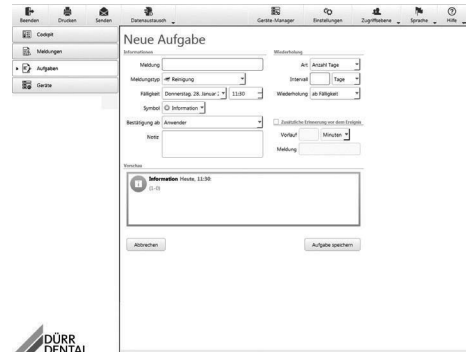

We recommend transferring the tasks from the maintenance schedule (see "15.1 Maintenance schedule") into the maintenance schedule of the software.

- › Select the **Tasks** view in the software.
- › Adding a task.

Result:

The task appears on the side bar and in the maintenance schedule.



13 Operation



De-energise the unit prior to working on it or in the event of potential danger (e. g. pull the mains plug) and prevent it from being switched back on again.

13.1 Operating panel

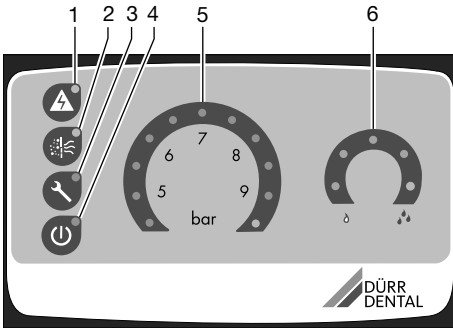

- 1 Fault button with orange LED
- 2 Filter change button with orange LED
- 3 Service key with blue LED
- 4 Standby button with blue LED
- 5 Pressure range display/adjustment
- 6 Pressure dew point display

Different messages and the status of the unit are displayed on the operating panel. In addition, different functions can be started via the buttons.

The device is operated via the operating panel of the main control. The auxiliary control is inactive (standby button flashing) and cannot be operated.

Buttons

Fault button



Display of alarm messages with different levels of importance. This can be faults, warning messages and information (see "Fault" "13.7 Emergency mode").

Filter replacement button



"Maintenance required" display for the various filters (see "15.2 Changing the filter").

Service key



Check of the safety valve and adjustment of the pressure range (see "13.7 Emergency mode" and "10.2 Checking the safety valve").

Standby button



Switching between normal operation and standby mode (see "13.3 Normal operation") and "13.4 Standby mode").

Pressure range

The pressure is displayed and can be adjusted in this area.

The pressure is displayed via:

- 1. Blue LED (≤ 4.5 bar): only illuminates while the pressure is building up during start-up operation
- 2. - 10. Blue LEDs (= 5 - 9 bar): these indicate the pressure status in increments of 0.5 bar
- 11. Orange LED (> 9 bar): the pressure in the container is too high (i.e. outside the adjustment range). Adjustment options (see "11.1 Adjustment of the switch-on/cut off pressure").

Pressure dew point

The current pressure dew point temperature is displayed in this area. The compressed air can cool down to this temperature without the water condensing.

The pressure dew point is displayed via:

- 4 blue LEDs: 0°C / 5°C / 10°C / 15°C
- 1-2 blue LEDs light up when the system is running in the normal working range.

1 orange LED: $\geq 20^\circ\text{C}$, i.e. dry compressed air is no longer ensured.

As soon as the orange LED lights up the blue LEDs go out.



13.2 Switching the unit on/off

- › Switch the unit on / off via the main power switch.

The compressor unit will start up automatically and fill the pressure vessel. When the cut-off pressure is reached, the compressor unit switches itself off automatically.

13.3 Normal operation

The unit is in normal operation as soon as the plug is inserted in the power outlet. The compressor runs until the cut off pressure is reached. The LEDs light up in the pressure range display.

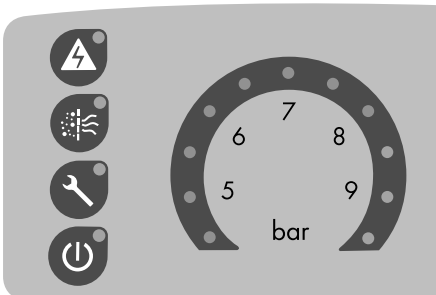

13.4 Standby mode

The following are possible in standby mode:

- you can switch off the unit without disconnecting it from the mains.
- You can switch to set-up mode.
- › Switching from normal mode to standby mode:

Standby button:  press for at least 2 seconds.

The LED comes on.

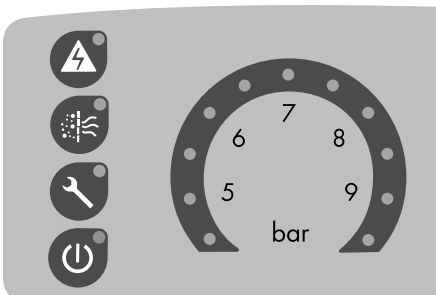

- › Press the standby button again  to switch to normal mode.

13.5 Auxiliary operation

If two compressors are operated in a singled compressed air network, then the two controls need to be configured as a main control and an auxiliary control.

Operation is deactivated on the control configured as the "auxiliary control" and the standby button flashes.

13.6 Set-up mode

The following can be carried out in set-up mode:

- Adjusting the pressure range (see "12.3 Adjustment of the switch-on/cut off pressure").
- Confirming filter replacement (see "15.2 Changing the filter").
- Deactivating emergency mode (see "13.7 Emergency mode").
- › In standby mode, press the service key as well  to go into set-up mode.

Fault

The control monitors the functions of the unit and signals faults according to their importance. Faults, warnings or information can be displayed. Faults are triggered as a result of faults in component assemblies or as a result of sensor defects. The unit is switched off and the LED of the fault button flashes or lights up.

 Fault button, orange LED *flashes*

Normal mode or emergency mode can be activated, see "13.7 Emergency mode").

 Fault button, orange LED *lights up*

As well as faults, the LED on the fault button also lights up to indicate warning messages and information.



The unit continues to operate in normal mode.

This keeps the operator informed about emergency mode, humidity, leaks or overheating.

Warning messages and information are automatically deactivated after the fault has been rectified, with exception of emergency mode.

13.7 Emergency mode

If a unit fails, the compressor can be switched to emergency mode:

-  Fault button, orange LED flashes.
1 aggregate has failed.
- > Flashing  fault button: press the button.
The compressor continues to run with one unit. The fault button lights up to indicate that emergency mode is active.
- > Have the necessary repairs to the unit carried out.

14 Monitoring the device with Tyscor Pulse

-  Weitere Informationen zu Tyscor Pulse finden sie in der Software-Hilfe und im Tyscor Pulse Handbuch Best.-Nr. A949100001.

14.1 Monitoring operation

The device must have been added to the cockpit for the graphical device block to be shown in the cockpit.



The following is shown in the unit block of the compressor:

- Current pressure in the pressure vessel
- Humidity in the pressure vessel







Symbols

If a message occurs for an device, the symbol next to the device in the side bar changes. The message appears in the cockpit and in the device details.

If several messages occur, the symbol of the highest message level in each case is displayed.

-  As soon as a message concerning a device occurs, the symbol in the task bar (or Mac OS menu bar) also changes to the relevant message symbol. If required by the message an acoustic signal also sounds.

› To query the message details, switch to the cockpit or to the device.

-  Trouble-free operation
-  Fault
Operation of the device interrupted
-  Warning
Operation of the device restricted
-  Note
Important information about the device
-  Information
-  Establishing a connection to the device
-  Connection to the device interrupted

14.2 Completing the task

Due tasks appear as a message in the cockpit.



-  The task can be assigned to an access level (operator, administrator or service technician), which then means that it can only be confirmed from this access level.

- › Perform the task.
- › Confirm the task in the software.

Result:

The due date of the task is set to the next date.

14.3 Creating a report

You can print out a current report  or sent it via e-mail .

The report contains all messages and a screenshot of the view that is displayed when the report is created.

15 Maintenance



De-energise the unit prior to working on it or in the event of potential danger (e. g. pull the mains plug) and prevent it from being switched back on again.

15.1 Maintenance schedule

Maintenance interval	Maintenance work
At regular intervals	<ul style="list-style-type: none"> › Empty the collector tray under the condensate separator (the interval may vary depending on the ambient conditions and method of working; empty it daily if the humidity is high).
Annually	<ul style="list-style-type: none"> › Replace the air intake filter - every six months given a high concentration of dust. › Change the fine filter cartridge 3 µm / 0.01 µm membrane-drying unit. › Replace the sintered filter.
Every 4 years	<ul style="list-style-type: none"> › Replace the vibration dampers.
In accordance with national directives	<ul style="list-style-type: none"> › Check the safety valve. › Carry out repeat safety tests (e.g. pressure vessel test, electrical safety test) in accordance with the national directives.

15.2 Changing the filter

 **NOTICE**
Shortened service life, bad air quality,
reduced delivery

- › Replace the filter 1x per year or as soon as the yellow LED lights up.

 Filter replacement button, yellow LED lights up.

 As soon as the LED lights up, it can be temporarily switched off by pressing the button. Every time the unit is switched back on the LED comes on again. The LED only goes out permanently once replacement of the filter has been confirmed in set-up mode.

Disconnecting the unit from the mains

- › Standby button:  press for at least 2 seconds.
- › Unplug the mains plug.

Replacing the air intake filter

- › Remove the noise reducer.

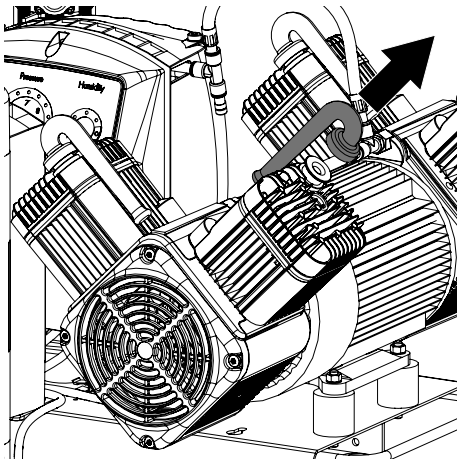

- › Remove the air intake filter.

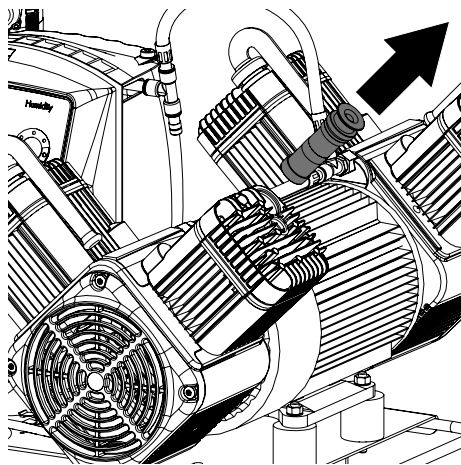

- › Insert a new air intake filter.
- › Replace the noise reducer.

Change the fine filter cartridge 3 µm / 0.01 µm of the membrane-drying unit

- › Check that the unit has been disconnected from the power supply and is depressurised.
- › Unscrew and remove the filter cover.
- › Remove the fine filter 3 µm / Fine filter 0.01 µm.
- › Fit a new 3 µm fine filter / 0.01 µm fine filter.
- › Replace the filter cover and close.

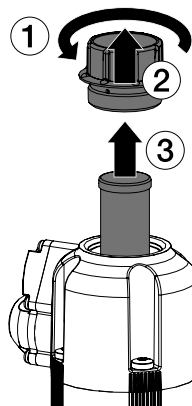



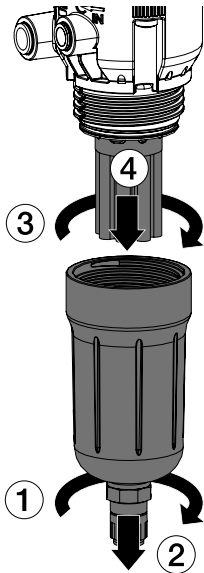

Replacing the sintered filter of the membrane drying unit

- › Unscrew and remove the filter housing.
- › Remove the sintered filter.
- › Insert a new sintered filter.
- › Replace the filter housing and close.



Confirming the filter replacement

- › Connect the mains plug.
- ›  press for at least 2 seconds.
- ›  press for at least 2 seconds. The unit is now in setup mode.
- ›  Orange LED flashes
- ›  Press to confirm filter replacement.

Resetting the unit to normal operation

- ›  Touch.

Resetting the unit to standby mode

- ›  Touch.

16 Taking out of use

16.1 Taking the unit out of use

If the compressor is not to be used for a longer period of time, we recommend that the unit be taken out of operation.

To do so, any accumulated condensation water must be drained from the pressure vessel and the membrane drying unit.

 The compressor must be running in order to drain the remaining condensation water in the water separator of the membrane drying unit.

- › Open the condensate drain valve on the membrane drying unit (approx. 3 turns).

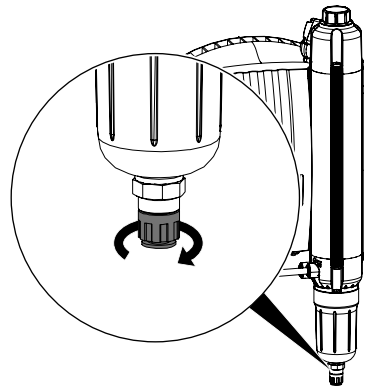

- › Open the condensate drain valve on the pressure vessel.

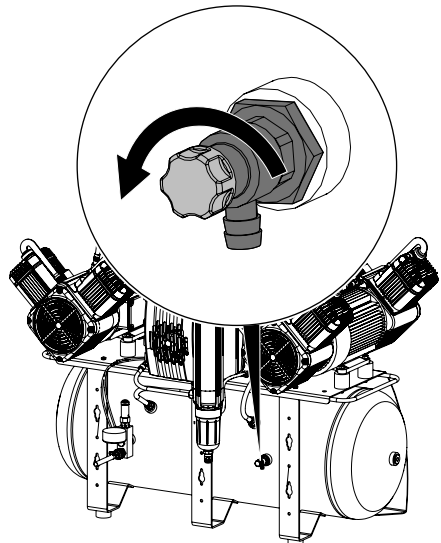

Once the switch-on pressure has been reached, the compressor will switch on.

- › Wait until no more condensation water emerges from the condensate drain valve on the membrane drying unit.
- › Switch off the unit - touch the  min. 2 seconds.
- › Wait until no more air leaves the condensate drain valve (tank empty).
- › Unplug at the mains.
- › Close the condensate drain valve on the pressure vessel.

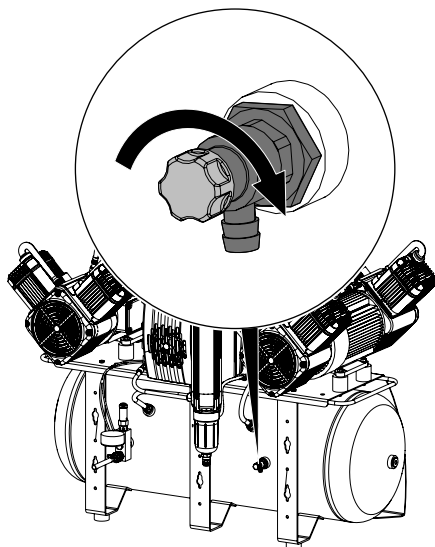

- › Close the condensate drain valve on the membrane drying unit.

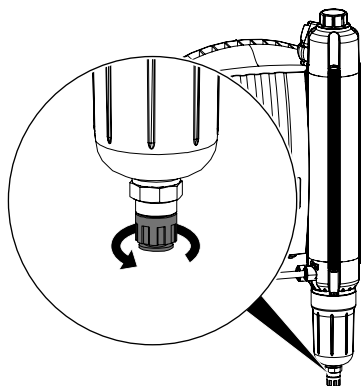

- › Disconnect the compressor from the pipe system.

16.2 Storage of the unit



WARNING

Risk of explosion of the pressure tank and pressure hoses

- › The pressure tank and the pressure hoses must be vented before they are stored or transported.
- › Protect the unit against moisture, dirt and extreme temperatures during transport (refer to the section on "Ambient conditions").
- › Only store the unit when it has been completely emptied.



17 Tips for operators



Any repairs above and beyond routine maintenance must only be carried out by suitably qualified personnel or by one of our service technicians.



De-energise the unit prior to working on it or in the event of potential danger (e. g. pull the mains plug) and prevent it from being switched back on again.

Problem	Probable cause	Solution
LED on the filter replacement button lights up	Filter replacement required	<ul style="list-style-type: none"> › Change the air intake filter, the 3 µm filter insert / 0.01µm fine filter insert and sinter filter (see "15.2 Changing the filter").
Compressor will not start	No display on the operating panel No mains voltage	<ul style="list-style-type: none"> › Check the main power switch, mains fuse and mains voltage, inform an electrician if necessary.
	Fault button flashes (if compressor is equipped with 2 units) Emergency mode possible	<ul style="list-style-type: none"> › Activate emergency mode: Press the fault button, (see "13.7 Emergency mode"). Compressor runs with 1 unit. › Inform a service technician
	Fault button lit up Compressor defective	<ul style="list-style-type: none"> › Disconnect the mains plug and inform a service technician.
Compressor starts up, no display on the operating panel	Operating panel defective	<ul style="list-style-type: none"> › Disconnect the mains plug and inform a service technician.

Problem	Probable cause	Solution
Compressor does not switch off or has difficulty reaching the cut off pressure	Excessive air extraction	› Check air requirements and dimensioning of the compressor.
	Air intake filter dirty	› Replace the air intake filter.
	Leak in the compressed air pipe network	› Check the compressed air pipe network, if necessary disconnect the mains plug and inform a service technician.
	Leak in the compressed air lines of the compressor station	› Check the pressure hoses on the compressor, membrane drying unit and distributor block; if necessary disconnect the mains plug and inform a service technician.
	Flow noise at the membrane drying unit	› Check the pressure hoses on the compressor; if necessary inform a service technician.
	Change in the delivery of the compressor unit	› Disconnect the mains plug and inform a service technician.
Compressor switches on without any compressed air being extracted	Compressor blows via the safety valve, The container pressure is not displayed correctly on the operating panel	› Disconnect the mains plug and inform a service technician.
	Leak in the compressed air pipe system	› Check the compressed air pipe system; if necessary disconnect the plug and inform a service technician.
Fault button flashing	Leak in the compressed air lines of the compressor	› Check the pressure hoses on the compressor, membrane drying unit and distributor block; if necessary disconnect the mains plug and inform a service technician.
	Compressor unit defective	› Activate emergency mode: press the fault button, (see "13.7 Emergency mode"). Compressor runs with 1 unit › Inform a service technician.
Fault button lit up	Unit is defective	› Unplug the mains plug. › Inform a service technician.
Knocking or loud noises on the compressor	Compressor unit defective	› Inform a service technician.

18 Tips for service technicians



The following information about troubleshooting is intended solely for service technicians. Repairs must only be carried out by service technicians.



De-energise the unit prior to working on it or in the event of potential danger (e. g. pull the mains plug) and prevent it from being switched back on again.

EN

Problem	Probable cause	Solution
Compressor will not start	No mains voltage. On three-phase units: one phase is missing or not connected (generation of a humming sound)	› Check the mains fuse; if necessary, switch the circuit breaker back on. If the fuse is defective, replace it. Check the mains supply voltage.
	Undervoltage or overvoltage	› Measure the supply voltage; call an electrician if necessary.
	Relief valve defective, unit starts against pressure	› Check that the relief valve discharges after switching off the unit. Free up the movement of the relief valve operable or replace it.
	Mechanical sluggishness of a unit (piston is stuck); motor protection has tripped	› Switch the unit off and disconnect it from the power supply, remove the fan hood from the blocked compressor and turn the fan wheel. If this is not possible, replace the piston and cylinder or the complete unit.
Humming noise from motor	Motor capacitor is defective	› Replace the capacitor.



Service

Dürr Technik GmbH & Co. KG
74301 Bietigheim-Bissingen
Telephone 0 71 42 / 90 22 - 20
Fax 0 71 42 / 90 22 - 99
e-mail: service@duerr-technik.de

Replacement order

Telephone 0 71 42 / 9022 - 0
Fax 0 71 42 / 9022 - 99
e-mail: office@duerr-technik.de

The following information is required when ordering spare parts:

- Type designation and item number
- Order number as appears on the spare parts list
- Quantity required
- Exact shipping address
- Shipping information

Repairs/return delivery

Ensure that the unit is **depressurized** before transport! Use the original packaging when returning units, if possible. Always pack the units in a plastic bag. Use recyclable packing material.

Return delivery address:

Dürr Technik GmbH & Co. KG
Pleidelsheimer Straße 30
74321 Bietigheim-Bissingen
-Germany-

International addresses for Dürr Technik

www.duerr-technik.com

Dürr Technik GmbH & Co. KG
Pleidelsheimer Strasse 30
74321 Bietigheim-Bissingen
Germany
Fon: +49 7142-90 22 -0
www.duerr-technik.com
office@duerr-technik.de

