

SICOLAB oil-free compressor station

EN



Installation and Operating Instructions

CE

0626900100L02



1506V003

Contents



Important information

1 Documentation	2
1.1 Warnings and symbols	2
1.2 Notes on copyright	2
2 Safety	3
2.1 Intended use	3
2.2 Incorrect use	3
2.3 General safety notes	3
2.4 Qualified personnel	3
2.5 Protection against electrical current	3
2.6 Only use original parts	3
2.7 Transportation and storage	3
2.8 Disposal	4



Product description

3 Overview	5
3.1 Unit without a membrane-drying unit (230 V)	5
3.2 Unit with a membrane-drying unit (230 V)	5
3.3 Unit with a membrane-drying unit (115 V)	5
3.4 Working parts and spare parts	6
4 Technical data	7
4.1 Unit without a membrane-drying unit (230 V)	7
4.2 Unit with a membrane-drying unit (230 V)	8
4.3 Unit with a membrane-drying unit (115 V)	9
4.4 Pressure receivers for 230 V units	10
4.5 Instructions for use – pressure receivers for 230 V units	11
4.6 Pressure receivers for 115 V units	12
4.7 Instructions for use – pressure receivers for 115 V units	12
4.8 Model identification plate	13
4.9 Declaration of conformity for machines in accordance with the 2006/42/EC Directive	14
5 Function	15

5.1 Unit without a membrane-drying unit	16
5.2 Unit with membrane drying unit	16



Mounting

6 Prerequisites	17
6.1 Area of installation	17
6.2 Pressure receiver test	17
7 Operation	18
7.1 Remove the packaging	18
7.2 Fit the spacer	18
7.3 Set up compressed air connection	18
7.4 Condensate	18
7.5 Electrical installation	18
7.6 Motor protection	19
7.7 Overtemperature protection	19



Usage

8 Instructions for use	20
8.1 Switch the unit on/off	20
8.2 Pressure reducer adjustment	20
9 Maintenance	21
9.1 Maintenance plan	21
9.2 Preparations when replacing a filter	22
9.3 Change the intake filter	22
9.4 Replace the 0.01 µm filter set (if fitted)	23
9.5 Replacing the filter of the membrane-drying unit	24
9.6 Replace the activated carbon filter (if fitted)	25



Trouble-shooting

10 Tips for Operators and Technicians	26
--	----



Addresses



Important information

1 Documentation

These assembly and operating instructions form an integral part of the unit. They correspond to the particular model of the unit and to the technical standards applicable at the time it was brought to market.

i In the event that the instructions and information in these assembly and operating instructions are not observed, Dürr Technik undertakes to provide no warranty and accepts no liability of any kind for the safe and reliable operation of the unit.

This translation has been produced to the best of our knowledge. The original German language version of the manual is definitive. Dürr Technik will not be held liable for translation errors.

1.1 Warnings and symbols

Warnings

The warnings in this document are there to point out possible injury to persons or damage to machinery.

The following warning symbols are used:



General warning symbol



Warning - dangerous electrical voltage



Warning - high temperatures



Warning - the unit starts up automatically

The warnings are structured as follows:



SIGNAL WORD

Description of the type and source of danger

The possible consequences from disregarding the warning are listed here

- Observe these measures in order to avoid the danger.

The signal word indicates one of the four danger levels of the warnings:

- **DANGER**
Immediate danger of serious or fatal injury
- **WARNING**
Possible danger of serious or fatal injury
- **CAUTION**
Danger of minor injury
- **WARNING**
Danger of extensive material damage

Further symbols

These symbols are used within the documentation and on the unit itself:



Notes, e.g. special instructions concerning economical use of the unit.



Observe the accompanying documentation.



Dispose of the unit properly and in accordance with applicable national, regional and local laws.



CE-labeling



Switch off the unit (i. e. unplug and disconnect from mains).

1.2 Notes on copyright

All circuits, processes, names, software programs and units specified are protected under industrial property rights.

The reprinting of the assembly and operating instructions, even in extracts, is only permitted with the written permission of Dürr Technik.

2 Safety

Dürr Technik has designed and developed the unit in such a way that danger is to a large extent excluded if the unit is used as intended. However, residual risks may be present. Therefore, please observe the following information.

2.1 Intended use

The unit is designed for compressing atmospheric air. This unit is designed to be operated in dry, ventilated rooms. The unit must not be operated in wet or damp environments. Use of the unit in the proximity of gases or combustible liquids is prohibited. Ensure that mobile units are stationary before operation.

2.2 Incorrect use

Any use of this unit above and beyond that specifically described in these instructions will be deemed to be as not according to the intended use. The manufacturer cannot be held liable for any damage resulting from incorrect usage. The user bears all risks.



WARNING

Serious injury and material damage due to improper usage

- Conveying explosive mixtures in any way other than that specified is not permitted.

2.3 General safety notes

- Before using the unit observe any and all guidelines, laws, regulations and other restrictions which may apply to the unit.
- Before each use check the function and condition of the unit.
- Do not convert or change the unit in any way.
- Observe the Installation and Operating Instructions precisely.
- Keep the Installation and Operating Instructions in an accessible place so that the operator has instant access to them.

2.4 Qualified personnel

Instructions for use

Persons who operate the unit must, on the basis of their training and knowledge, ensure safe and correct handling of the unit.

- Ensure personnel are trained in the correct usage of the unit.

Installation and repair

- Assembly and installation work, readjustments, modifications, upgrades and repairs must be carried out by Dürr Technik or personnel authorised and trained by Dürr Technik, who are familiar with the technology used in the unit and are aware of the risks involved when working on or operating the unit.

2.5 Protection against electrical current

- Observe all electrical safety regulations when working on the unit.
- Replace any damaged lines and plug and socket outlets immediately.

2.6 Only use original parts

- Only use accessories and special accessories that are specified or approved by Dürr Technik.
- Only use original wear parts and spare parts.



Dürr Technik accepts no liability for damage resulting from the use of non-approved accessories, special accessories or any wear parts or spare parts other than original parts.

2.7 Transportation and storage

The unit is shipped in a cardboard box filled with packaging padding. This packaging ensures that the unit is optimally protected in transit. As far as possible, always use the original packaging for transporting or storing the unit.

- Keep packaging away from children.



WARNING

Explosion of the pressure receiver and pressure hoses

Serious personal injury and material damage

- Ensure that the air has been evacuated from the pressure receiver and pressure hoses when they are stored and transported.
- Protect the unit against moisture during transit.
- Always transport the unit in an upright position.
- Only transport the unit using the transport handles provided.



The unit may be stored in its original packaging:

- in warm, dry and dust-free rooms;
- protected from contaminants.



If possible, retain the packaging material.

2.8 Disposal

Unit



Dispose of the unit properly and in accordance with applicable national, regional and local laws.

Packaging



Dispose of packaging material in an environmentally responsible manner.

- Note current disposal routes.
- Keep packaging away from children.



Product description

3 Overview

3.1 Unit without a membrane-drying unit (230 V)

Description	Article no.	Air intake filter	0.01 µm filter set
SICOLAB 062	0626 1100	●	—
SICOLAB 100	0626 2100	●	—
SICOLAB 200	0626 3100	● 2x	—
SICOLAB 062F	0626 1110	●	●
SICOLAB 100F	0626 2110	●	●
SICOLAB 200F	0626 3110	● 2x	●

- Available
- Not available

3.2 Unit with a membrane-drying unit (230 V)

Description	Article no.	Air intake filter	Sinter filter	3 µm fine filter	0.01 µm fine filter	Activated carbon filter
SICOLAB 062M	0626 1200	●	●	●	—	—
SICOLAB 100M	0626 2200	●	●	●	—	—
SICOLAB 200M	0626 3200	● 2x	●	●	—	—
SICOLAB 062MF	0626 1210	●	●	—	●	—
SICOLAB 100MF	0626 2210	●	●	—	●	—
SICOLAB 200MF	0626 3210	● 2x	●	—	●	—
SICOLAB 062MFA	0626 1220	●	●	—	●	●
SICOLAB 100MFA	0626 2220	●	●	—	●	●
SICOLAB 200MFA	0626 3220	● 2x	●	—	●	●

- Available
- Not available

3.3 Unit with a membrane-drying unit (115 V)

Description	Article no.	Air intake filter	Sinter filter	3 µm fine filter	0.01 µm fine filter	Activated carbon filter
SICOLAB 062M	0626 6200	●	●	●	—	—
SICOLAB 100M	0626 7200	●	●	●	—	—

- Available
- Not available

3.4 Working parts and spare parts

Spare parts for units without a membrane-drying unit

The following working parts need to be replaced at the specified maintenance intervals (see "9.1 Maintenance plan").

Spare parts		SICOLAB 062 / 100 / 200	SICOLAB 062F / 100F / 200F
Air intake filter (4)	Filter element	9000-416-31	9000-416-31
0.01 µm filter set: - Pre-filter (21) - Fine filter (20)	Filter element	—	0626100040

Spare parts for units with a membrane-drying unit

The following working parts need to be replaced at the specified maintenance intervals (see "9.1 Maintenance plan").

Spare parts		SICOLAB 062M / 100M / 200M	SICOLAB 062MF / 100MF / 200MF	SICOLAB 062MFA / 100MFA / 200MFA
Air intake filter (4)	Filter element	9000-416-31	9000-416-31	9000-416-31
3 µm fine filter (for membrane-drying unit)	Filter element	1610-121-00	—	—
0.01 µm fine filter (for membrane-drying unit)	Filter element	—	9000-416-0035ET	9000-416-0035ET
Sinter filter (for membrane-drying unit)	Filter element	1650-101-00	1650-101-00	1650-101-00
Activated carbon filter (6)	Filter element	—	—	9000-416-0025

Spare parts and accessories

Turning bolt key	0626 0071
SICOLAB 062xx fuses (mains fuse)	9000-115-14
SICOLAB 100xx fuses (mains fuse)	9000-115-46
SICOLAB 200xx fuses (mains fuse)	9000-115-0016
SICOLAB 062xx (115 V) fuses (mains fuse)	0626100046
SICOLAB 100xx (115 V) fuses (mains fuse)	0626100047
Blower pistol with hose	0654 0650

4 Technical data

4.1 Unit without a membrane-drying unit (230 V)

Electrical data		SICOLAB 062/062F	SICOLAB 100/100F	SICOLAB 200/200F
Electrical frequency	Hz	50	50	50
Nominal voltage	V	230	230	230
Rated power	kW	0.44	0.96	1.41
Nominal current	A	2.3	5.3	7.1
Mains fusing	A	4	8	10

General data				
Pressure receiver volume	l	25	25	25
Delivery at 50 Hz and 5 bar (0.5 MPa)	l/min	44	70	145
Delivery at 50 Hz and 7 bar (0.7 MPa)	l/min	35	59	121
Duty cycle	%	100 (S1)	100 (S1)	100 (S1)
Switch-on/cut-off pressure	bar (MPa)	6 - 8 (0.6 - 0.8)	6 - 8 (0.6 - 0.8)	6 - 8 (0.6 - 0.8)
Safety valve, maximum permissible operating pressure	bar (MPa)	10 (1)	10 (1)	10 (1)
Dimensions (LxWxH)	mm	510 x 580 x 653	510 x 580 x 653	510 x 580 x 653
Weight	kg	67	77	87
Noise level	dB(A)	48	51	54

Ambient conditions during operation				
Temperature	°C	+5 to +40	+5 to +40	+5 to +35
Relative humidity	%	Max. 95	Max. 95	Max. 95

Ambient conditions during storage and transport				
Temperature	°C	-25 to +55		
Relative humidity	%	10 % to 90 %		

**4.2 Unit with a membrane-drying unit (230 V)**

Electrical data		SICOLAB 062M/ 062MF/ 062MFA	SICOLAB 100M/ 100MF/ 100MFA	SICOLAB 200M/ 200MF/ 200MFA
Electrical frequency	Hz	50	50	50
Nominal voltage	V	230	230	230
Rated power	kW	0.44	0.96	1.41
Nominal current	A	2.3	5.3	7.1
Mains fusing	A	4	8	10

General data				
Pressure receiver volume	l	25	25	25
Delivery at 50 Hz and 5 bar (0.5 MPa)	l/min	37	59	122
Delivery at 50 Hz and 7 bar (0.7 MPa)	l/min	31	47	97
Duty cycle	%	100 (S1)	100 (S1)	100 (S1)
Switch-on/cut-off pressure	bar (MPa)	6 - 8 (0.6 - 0.8)	6 - 8 (0.6 - 0.8)	6 - 8 (0.6 - 0.8)
Safety valve, maximum permissible operating pressure	bar (MPa)	10 (1)	10 (1)	10 (1)
Pressure dew point (according to DIN ISO 8573-1)	Class	3	4	4
Dimensions (LxWxH)	mm	510 x 580 x 653	510 x 580 x 653	510 x 580 x 653
Weight	kg	69	79	89
Noise level	dB(A)	48	51	54

Ambient conditions during operation				
Temperature	°C	+5 to +40	+5 to +40	+5 to +35
Relative humidity	%	Max. 95	Max. 95	Max. 95

Ambient conditions during storage and transport				
Temperature	°C	-25 to +55		
Relative humidity	%	10 % to 90 %		

4.3 Unit with a membrane-drying unit (115 V)

Electrical data		SICOLAB 062M	SICOLAB 100M
Electrical frequency	Hz	60	60
Nominal voltage	V	115	115
Rated power	kW	0.56	1.15
Nominal current	A	5.6	11.8
Mains fusing	A	6.2	13.0

General data			
Pressure receiver volume	l	25	25
Delivery at 60 Hz and 5 bar (0.5 MPa)	l/min	36	67
Delivery at 60 Hz and 7 bar (0.7 MPa)	l/min	30	54
Duty cycle	%	100 (S1)	100 (S1)
Switch-on/cut-off pressure	bar (MPa)	6 - 8 (0.6 - 0.8)	6 - 8 (0.6 - 0.8)
Safety valve, maximum permissible operating pressure	bar (MPa)	10 (1)	10 (1)
Pressure dew point (according to DIN ISO 8573-1)	Class	3	4
Dimensions (LxWxH)	mm	510 x 580 x 653	510 x 580 x 653
Weight	kg	77	87
Noise level	dB(A)	49	53

Ambient conditions during operation			
Temperature	°C	+5 to +40	+5 to +40
Relative humidity	%	Max. 95	Max. 95

Ambient conditions during storage and transport			
Temperature	°C	-25 to +55	
Relative humidity	%	10 % to 90 %	

4.4 Pressure receivers for 230 V units

Pressure receivers from Behälter-Werk Burgau GmbH are installed in the unit.

The instructions for use given below apply to the following pressure receiver type:

Type	Pressure ¹⁾	Receiver ²⁾	App ³⁾	c ⁴⁾	Note ⁵⁾
316034 / 5430-200-51	PS 10 bar	V 25 l	B	c = 0 mm	1; 6

For serial number and year of manufacture, see receiver marking

¹⁾ Pressure	Maximum operating pressure PS in bar
²⁾ Receiver	Receiver volume V in litres
³⁾ Application (App)	B = Pressure receiver for stationary systems
⁴⁾ Corrosion allowance	c in mm
Maximum temperature	+100 °C
Minimum temperature	-10 °C
Medium	Air/nitrogen
⁵⁾ Note	1: The receiver is capable of sustained operation within a pressure fluctuation range of 1.6 bar (10 % PS)
	6: The condensate must be drained under internal pressure in accordance with the operating manual
Standards applied	EN 286-1:1998

4.5 Instructions for use – pressure receivers for 230 V units

The pressure receiver may only be within the limits of the purpose of use and technical data described above. Any use other than as indicated is not permitted for reasons of safety. The pressure receiver was constructed in accordance with Directive 2009/105/ EG and was manufactured as a single component without safety-related equipment for the field of application indicated. The unit was designed for internal compressive stress.

Before commissioning, the receiver must be provided with the required safety equipment, such as a pressure gauge, safety equipment to prevent overpressure, etc. These parts are not included in the scope of our delivery.

No welding work or heat treatment may be carried out on the pressure-retaining walls of the receiver. It must be ensured that the internal pressure does not exceed the operating pressure PS “under normal operating conditions” indicated in the receiver marking. For a short time, however, this pressure may be exceeded by up to 10 %. Vibration stress which would be damaging for the pressure receiver, as well as corrosion on the receiver, must be prevented using appropriate measures.

The pressure receiver must be assembled and installed such that it is safe to use (e.g. no rigid connection to the floor or machine base frame without vibration dampers).

Taking the equipment parts into consideration, the operating instructions to be drawn up by the supplier must contain the following:

- a) Instructions on draining the condensate
- b) Instructions and information on maintenance to ensure safety of use

The supplier must additionally determine whether the pressure receiver, when equipped ready for use, must undergo an inspection test before commissioning. The supplier/operator is required to comply with applicable laws and regulations relating to the operation of the pressure receiver in the country of use.

The receiver is capable of sustained operation within a pressure fluctuation range of $\Delta p \leq 20\%$ of the maximum operating pressure PS.

Remarks: See "4.4 Pressure receivers for 230 V units".

4.6 Pressure receivers for 115 V units

Pressure receivers from Behälter-Werk Burgau GmbH are installed in the unit.

The instructions for use given below apply to the following pressure receiver type:

Type	Pressure ¹⁾	Receiver ²⁾	App ³⁾	c ⁴⁾	Remark
316205 / 5110-200-0052	PS 10 bar	V 25 l	B	c = 0 mm	-

For serial number and year of manufacture, see receiver marking

¹⁾ Pressure	Maximum operating pressure PS in bar
²⁾ Receiver	Receiver volume V in litres
³⁾ Application (App)	B = Pressure receiver for stationary systems
⁴⁾ Corrosion allowance	c in mm
Maximum temperature	+100 °C
Minimum temperature	-10 °C
Medium	Air/nitrogen
Standards applied	ASME Code, Section VIII Div. 1

4.7 Instructions for use – pressure receivers for 115 V units

The pressure receiver has been manufactured as a single component without safety equipment. The pressure receiver may only be within the limits of the purpose of use and technical data described above. Any use other than as indicated is not permitted for reasons of safety.

The receiver has been designed for predominantly static internal compressive stress.

Before commissioning, the receiver must be provided with the required safety equipment, such as a pressure gauge, safety equipment to prevent overpressure, etc. These parts are not included in our scope of delivery.

No welding work or heat treatment may be carried out on the pressure-retaining walls of the receiver. Vibration stress which would be damaging for the pressure receiver, as well as corrosion on the receiver, must be prevented using appropriate measures.

The pressure receiver must be assembled and installed such that it is safe to use (e.g. no rigid connection to the floor or machine base frame without suitable vibration dampers).

Taking the equipment parts into consideration, the operating instructions to be drawn up by the supplier must contain the following:

- a) Instructions on draining the condensate
- b) Instructions and information on maintenance to ensure safety of use

The supplier must additionally determine whether the pressure receiver, when equipped ready for use, must undergo an inspection test before commissioning. The supplier/operator is required to comply with applicable laws and regulations relating to the operation of the pressure receiver in the country of use.

Remarks: None.



4.8 Model identification plate

The model identification plate is located on the back of the unit.

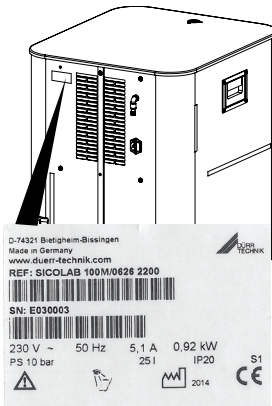

REF Order number

SN Serial number

This information is also required when ordering spare parts.



4.9 Declaration of conformity for machines in accordance with the 2006/42/EC Directive

The manufacturer hereby declares that the machine complies with the requirements of the Directive cited above and the requirements of the following additional directives:

- Electromagnetic Compatibility (EMC) Directive 2004/108/EC
- Simple pressure vessel directive 2009/105/EC in its current version
- RoHS directive 2011/65/EU

Name of manufacturer:	Dürr Technik GmbH & Co. KG
Address of the manufacturer:	Pleidelzheimer Straße 30 74321 Bietigheim-Bissingen, Germany

Reference number:	0626
Article description:	SICOLAB
From serial number:	D 000100

We hereby declare that the machine must not be commissioned until it has been established that the machine into which this machine is to be installed complies with the provisions as set out in Machinery Directive 2006/42/EC.

The following harmonised standards and other standards have been applied:

DIN EN 1012-1:2011-02
 DIN EN 60034-1: 2011-02
 DIN EN 60034-5: 2007-09
 DIN EN 60335-1:2012-10
 DIN EN 61000-6-2:2006-03
 DIN EN 61000-6-3:2011-09
 DIN EN 60204-1:2007-06
 DIN EN ISO 12100:2011-09

Bietigheim-Bissingen, 18.08.2014

Andreas Ripsam
 General manager at Dürr Technik

Proof of signature in the
 original document in the Dürr Technik archive



5 Function

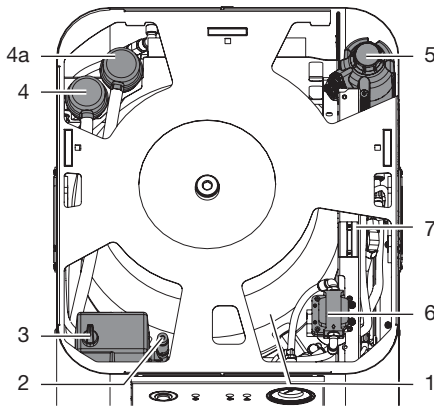

Figure 1: SICOLAB 0626 3220 top view (with-out unit cover)

- 1 Pressure receiver
- 2 Safety valve
- 3 Pressure switch
- 4 Air intake filter
- 4a Air intake filter*
- 5 Membrane-drying unit (optional)
- 6 Activated carbon filter (optional)
- 7 Operating time counter

* only with the following unit versions:
SICOLAB 200/ 200F/200M/ 200MF/200MFA

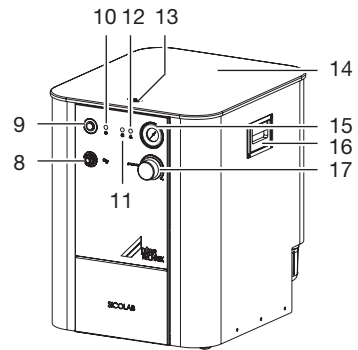

Figure 2: SICOLAB 0626 3220 front view

- 8 Quick-release coupling (choked)
- 9 On/Off switch
- 10 Green "Unit ready for operation" indicator lamp
- 11 Green "Compressor running" indicator lamp
- 12 Red "Temperature too high" warning lamp
- 13 Unit cover lock
- 14 Unit cover
- 15 Pressure gauge
- 16 Transport handle
- 17 Pressure reducer

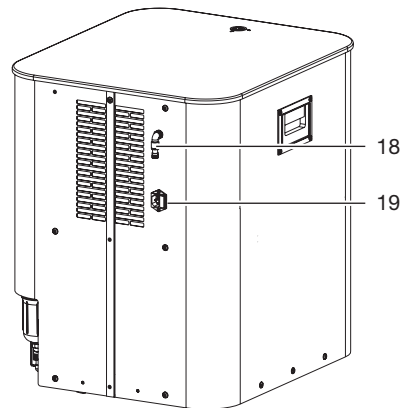

Figure 3: SICOLAB 0626 3220 rear view

- 18 Compressed-air connection (plug-in connection Ø10 mm) (unchoked)
- 19 Inlet connector with fuses



5.1 Unit without a membrane-drying unit

The unit draws in atmospheric air and compresses it. The oil-free compressed air is then transported via the cooler to the pressure receiver. The oil-free and filtered air is made available to the consumers in the pressure receiver. If compressed air is removed for a consumer, the receiver pressure drops. When the switch-on pressure has been reached, the unit is automatically switched on again via the pressure switch. When the cut-off pressure has been reached, the unit is automatically switched off. A safety valve prevents the maximum permissible receiver pressure from being exceeded.

5.2 Unit with membrane-drying unit

The unit draws in atmospheric air and compresses it. It then transports the oil-free compressed air to the membrane-drying unit. The cooler and the membrane dryer extract any moisture from the compressed air. The oil-free, hygienic and dry air is made available to the consumers in the pressure receiver.

If compressed air is removed for a consumer, the receiver pressure drops. When the switch-on pressure has been reached, the unit is automatically switched on again via the pressure switch. When the cut-off pressure has been reached, the unit is automatically switched off. A safety valve prevents the maximum permissible receiver pressure from being exceeded.



Mounting

6 Prerequisites

6.1 Area of installation

The installation area must fulfil the following requirements:

- Closed, dry, well ventilated room
- Not a purpose-built room (e. g. heating or wet room)
- Install the unit on a clean, level and sufficiently stable surface (take the weight of the unit into account).
- Install or fit the unit so that the type plate can be easily read and that the unit is easily accessible for operation and maintenance.
- Install the unit so that the socket outlet to which the unit is connected is easily accessible.
- Room temperature: +5 °C to +40 °C (for SICOLAB 062/062F/062M/062MF/062MFA/100/100F/100M/100MF/100MFA).
- Room temperature: +5 °C to +35 °C (for SICOLAB 200/200F/200M/200MF/200MFA).
- Ensure that a sufficient distance to the wall is maintained, so that the air can flow in and out without any obstruction.



The air is filtered during the intake. The composition of the air is not affected in the process. The air taken in should be free of harmful substances (e.g. do not draw in air from a basement garage or from directly next to a suction machine).



NOTICE

Risk of overheating due to insufficient ventilation

The unit produces heat. This can lead to heat damage and/or to a reduction in the service life of the unit.

- Do not cover the unit.
- Air must be able to flow in and out unobstructed.
- Ventilation openings must be sufficiently large.
- For installed units, an independent ventilation system may be required in unfavourable cases.

6.2 Pressure receiver test



The operator must comply with the national directives.

Example for Germany: German Ordinance on Industrial Safety and Health (BetrSichV)

7 Operation

7.1 Remove the packaging

For safe transportation, the unit is securely protected with packaging material.

- Remove the packaging material.
- Remove the protective film.
- Check the unit for damage in transit.
- Only lift the unit using the transport handles and/or from the floor.

7.2 Fit the spacer

- Fit the spacer (22) to the back of the unit to guarantee ventilation (leave the spacer in place throughout the service life of the unit).

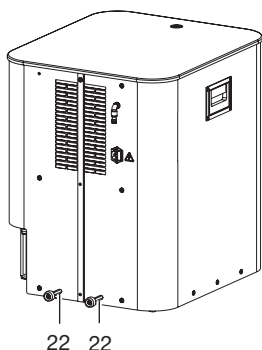

7.3 Set up compressed air connection

The unit has two compressed-air connections. The compressed-air connection takes the form of a quick-release coupling on the operating panel. The compressed-air connection on the back of the unit takes the form of a plug-in connection. The compressed-air connections can be used individually or together.

Quick-release coupling - operating panel

i The compressed-air connection to the pressure reducer has a constant pressure (set at the factory) of 0 - 6 bar (adjustable on the rotary knob).

- Compressed air is extracted at the quick-release coupling (7.2 mm) via a hose adapter piece on the unit's operating panel.
- Secure the pressure hose to the hose adapter piece using a hose clip.

- Connect the hose adapter piece to the quick-release coupling.

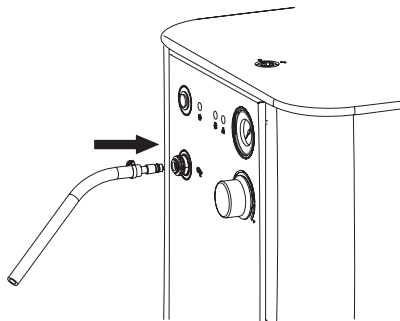

Plug-in connection - back of unit

i The compressed-air connection on the back of the unit has the unreduced receiver pressure. This varies between 6 and 8 bar (factory setting). This must be taken into account when connecting to a mains line. Any flow from the mains line into the unit is prevented via an internal check valve.

- Connect the flexible pressure hose with plug-in connection (10 mm) to the compressed-air connection on the back of the unit.

7.4 Condensate

The unit has a vaporisation system. However, at high ambient temperatures (> 30 °C) and at high levels of humidity (> 75 % RH), condensate may not be fully vaporised. Any remaining condensate is then drained off to the outside via a condensate overflow. In these applications, a condensate collection tank must be placed beneath the condensate overflow.

7.5 Electrical installation

- Connect the mains cable to the inlet connector on the back of the unit
- Connect the mains cable to a properly installed socket with PE conductor.
- Lay the mains cable without any mechanical tension.
- Before commissioning, compare the power supply voltage to the voltage information on the type plate.

**DANGER****Electric shock due to damaged mains cable or connector**

Electric shocks can cause serious personal injury

- If the mains cable or connector is damaged, do not start up the unit.
- Replace the damaged mains cable.

7.6 Motor protection

The motors in the units are equipped with a motor protection switch that switches off the pressure switch in the event of overcurrent. Overcurrent may be caused by faults (e.g. blockages). In cases such as these, the cause of the fault must first be determined and then eliminated.



The unit can be switched back on using the rotary knob on the pressure switch.

- Allow the unit to cool down.
- Switch off the unit.
- Disconnect the mains plug and prevent the unit from being switched back on again.
- Open the unit lock.
- Remove the unit cover.
- Switch the rotary knob on the pressure switch back on.
- Refit the unit cover.

7.7 Overtemperature protection

The motors in the units are equipped with a temperature switch that switches the unit off if it overheats. In cases such as these, the cause of the fault must first be determined and then eliminated.



If the unit is switched off via the temperature switch, the unit's fan continues to run.

**NOTICE****Automatic unit start-up after cooling down**

- Allow the unit to cool down



Usage

8 Instructions for use



Prior to working on the unit or in case of danger, disconnect it from the mains (e. g. pull the plug).

8.1 Switch the unit on/off

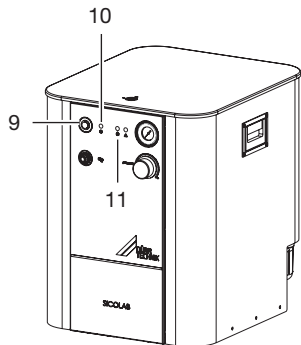

- 9 On/Off switch
- 10 Green "Unit ready for operation" indicator lamp
- 11 Green "Compressor running" indicator lamp

- The unit is switched on by pressing the on/off switch (9).

The unit starts up and the pressure receiver is filled. The green indicator lamps (10,11) light up. Once the cut-off pressure has been reached, the unit switches off automatically. The indicator lamp (11) goes out.

- The unit is switched off by pressing the on/off switch (9) again

The green indicator lamp (10) goes out.

Maximum operating pressure:	10 bar
Switch-on/cut-off pressure:	6 / 8 bar

8.2 Pressure reducer adjustment

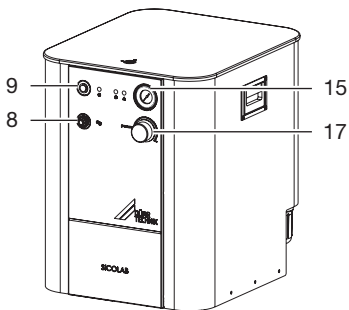

- 8 Quick-release coupling
- 9 On/Off switch
- 15 Pressure gauge
- 17 Pressure reducer

The pressure reducer (17) regulates the desired working pressure at the quick-release coupling (8).

The pressure reducer (17) can be adjusted. The maximum constant working pressure is 6 bar.

Setting the pressure reducer:

The constant working pressure can be adjusted by turning the pressure reducer (17). The pressure can be read off the pressure gauge (15).

- **To increase supply pressure:** Turn the pressure reducer (17) clockwise towards "+".
- **To decrease the supply pressure:** Turn the pressure reducer (17) anti-clockwise towards "-".

9 Maintenance



De-energise the unit prior to working on it or in the event of potential hazards (e. g. pull the mains plug) and prevent it from being switched back on again.

9.1 Maintenance plan

Maintenance interval	Maintenance work
Annually	<ul style="list-style-type: none"> Replace the air intake filter – if there is a high concentration of dust, this must be carried out every six months (see "9.3 Change the intake filter")
Annually	<ul style="list-style-type: none"> On units without a membrane-drying unit: Replace the 0.01 µm filter set (fine filter and pre-filter (see "9.4 Replace the 0.01 µm filter set (if fitted)"))
Annually	<ul style="list-style-type: none"> On units with a membrane-drying unit: Replace the 0.3 µm fine filter or the 0.01 µm fine filter in the membrane-drying unit (see "9.5 Replacing the filter of the membrane-drying unit")
Annually	<ul style="list-style-type: none"> On units with a membrane-drying unit: Replace the sinter filter in the membrane-drying unit (see "9.5 Replacing the filter of the membrane-drying unit")
Annually	<ul style="list-style-type: none"> Replace the activated carbon filter (see "9.6 Replace the activated carbon filter (if fitted)")
In accordance with the respective national law	<ul style="list-style-type: none"> Carry out repeat safety inspections (e.g. pressure receiver inspection, electrical safety inspection) in accordance with the respective national law.



Videos of maintenance work can be found at: www.duerr-technik.com.

9.2 Preparations when replacing a filter

The following steps must first be carried out before performing maintenance work on the unit:

- Allow the unit to cool down.
- Switch off the unit.
- Disconnect the mains plug and prevent the unit from being switched back on again.
- Evacuate the unit using the blower pistol (accessory) connected to the quick-release coupling until the pressure gauge displays 0 bar.
- Open the lock on the unit cover.
- Lift up and remove the unit cover.

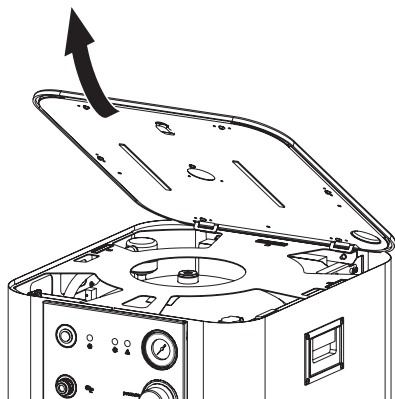

9.3 Change the air intake filter

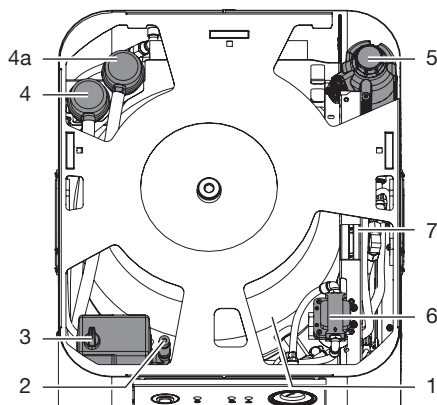

- 4 Air intake filter
- 4a Air intake filter (if fitted)

- Check that the unit has been disconnected from the power supply and is depressurised.

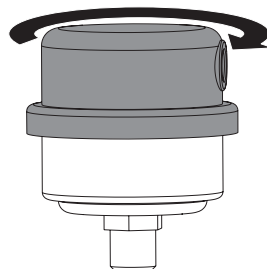

- Open the cover (1) of the air intake filter by turning it clockwise.
- Remove the (white) filter element.
- Insert a new filter element.
- Close the cover of the air intake filter by turning it anti-clockwise.
- Fit the unit cover.

9.4 Replace the 0.01 µm filter set (if fitted)

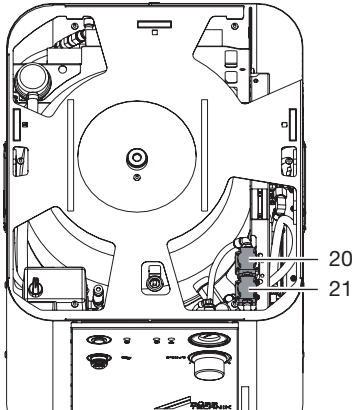
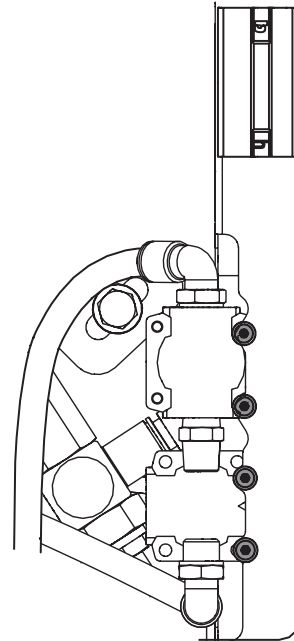

Figure 4: SICOLAB 0626 2110 with fine filter and pre-filter (without a membrane-drying unit)

- 20 Fine filter
- 21 Pre-filter

- Check that the unit has been disconnected from the power supply and is depressurised.



- Undo the screw connection on the fine filter and pre-filter using a 17 mm spanner.

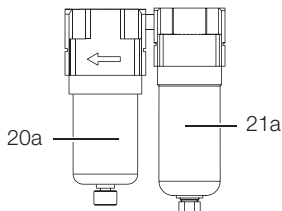

- 20a Fine filter cover
- 21a Pre-filter cover

- Undo the fine filter and pre-filter fixing screws on the unit frame.

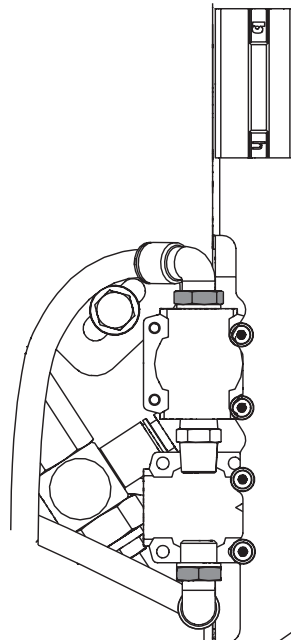



- Pull the pre-filter and fine filter upwards and out until the condensate hose on the pre-filter can be removed.
- Remove the condensate hose.

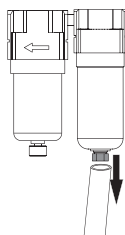

- Remove the pre-filter cover (21a) by turning it anti-clockwise.
- Remove the fine filter cover (20a) by turning it anti-clockwise.

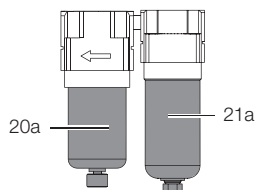

- Unscrew the used pre-filter filter element (white) and then screw in a new pre-filter filter element.
- Unscrew the used fine filter filter element (black) and then screw in a new fine filter filter element.
- Close the cover (20a and 21a) by turning it clockwise.
- Attach the condensate hose to the pre-filter.
- Position the pre-filter and fine filter in the unit and fit the screw connections.
- Attach the pre-filter and fine filter to the unit frame using fixing screws.
- Fit the unit cover.

9.5 Replacing the filter of the membrane-drying unit

- Check that the unit has been disconnected from the power supply and is depressurised.
- Unscrew and remove the filter cover.
- Remove the 3 µm fine filter/0.01 µm fine filter.
- Fit a new 3 µm fine filter/0.01 µm fine filter.
- Replace the filter cover and close.

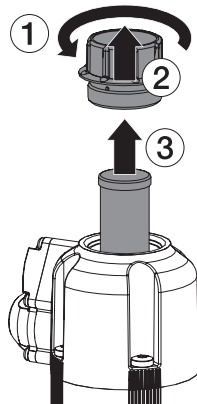

- Remove the L-shaped screw connection from the filter housing.
- Unscrew and remove the filter housing.
- Remove the sinter filter.
- Insert a new sinter filter.
- Replace the filter housing and close.
- Fit the unit cover.

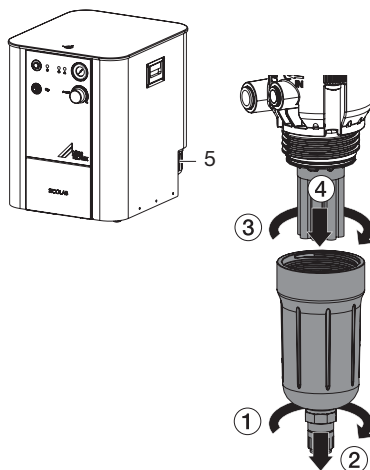

5 Membrane-drying unit (optional)

9.6 Replace the activated carbon filter (if fitted)

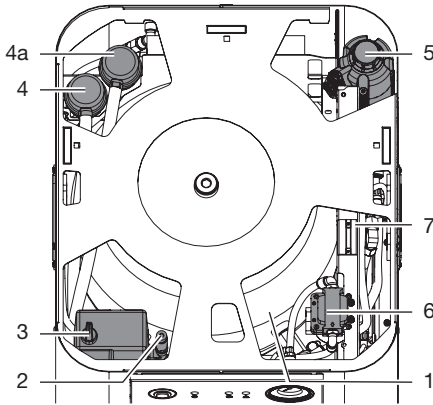
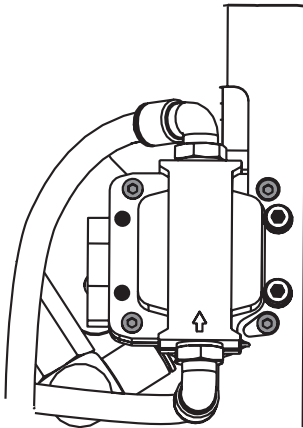

Figure 5: SICOLAB 0626 3220 with activated carbon filter and membrane-drying unit

6 Activated carbon filter

- Check that the unit has been disconnected from the power supply and is depressurised.
- Undo the four fixing screws on the activated carbon filter cover.



- Remove the lower part of the activated carbon filter.

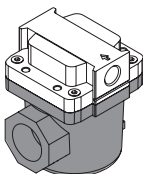

- Replace the filter element in the activated carbon filter.
- Attach the lower part of the activated carbon filter to the activated carbon filter cover using fixing screws.
- Fit the unit cover.



Trouble-shooting

10 Tips for Operators and Technicians



Repairs above and beyond simple maintenance may only be carried out by a qualified technician or one of our service technicians.



Prior to working on the unit or in case of danger, disconnect it from the mains (e. g. pull the plug).

Problem	Probable cause	Solution
The unit will not start up	No mains supply voltage. The green "Unit ready for operation" indicator lamp does not light up	<ul style="list-style-type: none"> • Switch on the unit. (The green "Unit ready for operation" indicator lamp lights up). • Check that the power supply complies with the specifications on the type plate. • Check the mains plug. • Check the fuses on the inlet connector and replace them if necessary.
	Air intake filter blocked	<ul style="list-style-type: none"> • Insert a new air intake filter.
	The red "Temperature too high" warning lamp lights up	<ul style="list-style-type: none"> • Disconnect the unit from the mains and allow it to cool down • Reduce the ambient temperature. • Contact customer service.
	Compressor is overloaded	<ul style="list-style-type: none"> • Disconnect the unit from the mains and allow it to cool down. • Reduce the ambient temperature. • Check that the application is suitable. • Contact customer service.
Unit too noisy	Mechanical damage	<ul style="list-style-type: none"> • Contact customer service.
Unit does not turn off even though air is being removed	Leak in the system	<ul style="list-style-type: none"> • Check external lines for leaks. • Contact customer service.
Output dripping	Air intake filter dirty	<ul style="list-style-type: none"> • Replace the air intake filter at least once a year. The air intake filter must never be cleaned.
	Excessive ambient temperature	<ul style="list-style-type: none"> • Ensure that cooling is more effective.
	Unsuitable materials drawn in	<ul style="list-style-type: none"> • Only convey approved materials.
Water dripping from air consumers	Defective membrane-drying unit	<ul style="list-style-type: none"> • Contact customer service.



Addresses

Service

Dürr Technik GmbH & Co. KG
74301 Bietigheim-Bissingen
Tel +49 (0)71 4290 2220
Fax +49 (0)71 4290 2299
E-mail: service@duerr-technik.de

Spare parts orders

Tel +49 (0)71 4290 0
Fax +49 (0)71 4290 99
E-mail: office@duerr-technik.de

Please provide the following information when ordering spare parts:

- Type code and article number
- Order number as appears on the spare parts list
- Quantity required
- Exact shipping address
- Shipping information

Repairs / returns

Please **depressurise** the unit before transporting it. If possible, please use the original packaging when returning units. Always pack the units in a plastic bag. Please use recyclable packing material.

Return address

Dürr Technik GmbH & Co. KG
Pleidelsheimer Straße 30
74321 Bietigheim-Bissingen
-Germany-

International addresses for Dürr Technik

www.duerr-technik.com

Dürr Technik GmbH & Co. KG
Pleidelsheimer Strasse 30
74321 Bietigheim-Bissingen
Germany
Fon: +49 7142-90 22 -0
www.duerr-technik.com
office@duerr-technik.de

