

Oil-free compressor station P2B 304

EN

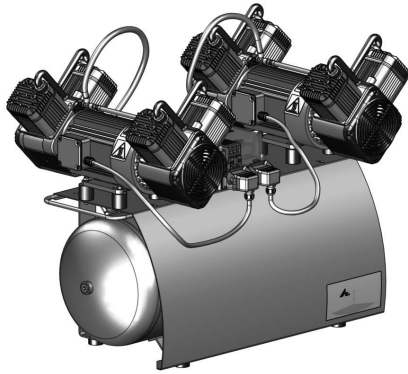

Installation and Operating Instructions

CE

1036100102L02



 **DÜRR
TECHNIK**

1608V001

Contents



Important information

1 About this document	2
1.1 Warnings and symbols	2
1.2 Copyright information	2
2 Safety	3
2.1 Intended use	3
2.2 Improper use	3
2.3 General safety information	3
2.4 Qualified personnel	3
2.5 Protection from electric shock	3
2.6 Only use genuine parts	3
2.7 Transportation and storage	4
2.8 Disposal	4



Product description

3 Overview	5
3.1 Scope of delivery	5
3.2 Special accessories	5
3.3 Wear parts and spare parts	5
4 Technical data	6
4.1 Declaration of conformity for machines in accordance with the 2006/42/EC Directive	7
4.2 Type plate	8
5 Operation	9



Installation

6 Requirements	10
6.1 Installation/setup room	10
6.2 Setup	10
6.3 Information about electrical connections	10
7 Transport	11
7.1 Remove the transport locks	11
8 Installing the compressor unit	11
8.1 Connect the compressor	12
9 Installation	13
9.1 Establishing the compressed air connection	13

9.2 Pressure reducer	13
9.3 Condensed water	13
9.4 Electrical connections	14

10 Commissioning and first start-up 14

10.1 Check the motor protection switch	14
10.2 Checking the switch-on/cut-off pressure	15
10.3 Checking the safety valve	15
10.4 Adjusting the rate of flow at the pressure reducer	16
10.5 Adjustment options	16

11 Circuit diagrams 18



Operation

12 Operation	19
12.1 Switching the unit on/off	19
12.2 Taking out of use	19
13 Maintenance	20
13.1 Maintenance schedule	20
13.2 Replacing the air intake filter	21



Troubleshooting

14 Tips for operators and service technicians	22
15 Tips for service technicians	23



Addresses



Important information

1 About this document

These installation and operating instructions represent a part of the unit. They correspond to the relevant version of the unit and the status of technology valid at the time of its market launch.



In the event that the instructions and notes in these installation and operating instructions for are not observed, Dürr Technik accepts no warranty or liability of any kind for the safe operation and reliable function of the units.

This translation was prepared to the best of our knowledge. The original German language version of the manual is the definitive version. Dürr Technik is not liable for translation errors.

1.1 Warnings and symbols

Warnings

The warnings in this document are intended to draw your attention to possible injury to persons or damage to machinery.

The following warning symbols are used:



General warning symbol



Warning – dangerous high voltage



Warning – hot surfaces



Warning - automatic start-up of the unit

The warnings are structured as follows:



SIGNAL WORD

Description of the type and source of danger

Here you will find the possible consequences of ignoring the warning

- › Follow these measures to avoid the danger.

The signal word differentiates between four levels of danger:

- **DANGER**
Immediate danger of severe injury or death
- **WARNING**
Possible danger of severe injury or death
- **CAUTION**
Risk of minor injuries
- **NOTICE**
Risk of extensive material/property damage

Other symbols

These symbols are used in the document and on or in the unit:



Note, e.g. specific instructions regarding efficient and cost-effective use of the unit.



Comply with the specification in the accompanying documents.



CE labelling



Date of manufacture



Order number



Serial number



Dispose of the unit properly and in accordance with applicable national, regional and local laws.



Air



Switch off and de-energise the device (e. g. unplug from mains).

1.2 Copyright information

All names of circuits, processes, names, software programs and units used in this document are protected by copyright.

The reprinting of the installation and operating instructions, even in extracts, is only permitted with the written permission of Dürr Technik.

2 Safety

Dürr Technik has developed and constructed the units in such a way that danger is to a large extent excluded if the units are used as intended. Nevertheless, residual risks can remain. You should therefore observe the following notes.

2.1 Intended use

The unit is intended for the compression of atmospheric air. The unit has been designed for operation in dry, ventilated rooms. The unit must not be operated in a damp or wet environment. Its use in the vicinity of gases or flammable liquids is prohibited. Only operate the mobile units in an upright position.

2.2 Improper use

Any other usage or usage beyond this scope is deemed to be improper. The manufacturer accepts no liability for damage resulting from such use. In such cases, the user/operator will bear the sole risk.



WARNING

Serious injury and material damage due to improper usage

- › Conveying explosive mixtures in any way other than that specified is not permitted.

2.3 General safety information

- › When operating this unit, always observe all directives, laws, and other rules and regulations applicable at the site of operation.
- › Check the function and state of the unit prior to each use.
- › Do not convert or modify the unit.
- › Comply with the specifications of the Installation and Operating Instructions.
- › Ensure that the unit operator has access to the Installation and Operating Instructions at all times.

2.4 Qualified personnel

Operation

Unit operators must ensure safe and correct handling based on their training and knowledge.

- › Instruct or have every operator instructed in the handling of the unit.

Installation and repairs

- › Always arrange for any assembly work, readjustments, alterations, extensions, and repairs to be performed by Dürr Technik or by personnel authorised and trained by Dürr Technik. Qualified personnel are defined as those trained by Dürr Technik; who are familiar with the unit technology; and are aware of the dangers presented by the unit.

2.5 Protection from electric shock

- › When working on the units observe all the relevant electrical safety regulations.
- › Immediately replace any damaged cables or plugs.

2.6 Only use genuine parts

- › Only use accessories and special accessories that are specified or approved by Dürr Technik.
- › Only use original working and spare parts.



Dürr Technik accepts no liability for damage resulting from the use of non-approved accessories, special accessories or any working parts or spare parts other than original parts.

2.7 Transportation and storage

The unit is delivered in a cardboard box filled with packing material. The original packaging provides optimum protection for the unit during transport. Wherever possible, always use the original packaging for transport and storage of the unit.

- Keep the packing materials out of the reach of children.



WARNING

Risk of explosion of the pressure vessel and pressure hoses

- › The pressure vessel and the pressure hoses must be vented before they are stored or transported.
- › Protect the unit from moisture during transportation.
- › Always transport the unit in an upright position.
- › Only transport the unit using the transport handles provided.
- › Do not transport the unit by the air intake filter.

The unit may be stored in its original packaging

- in warm, dry and dust-free rooms;
- protected from contaminants.



If possible, retain the packaging material.

2.8 Disposal

Unit



Dispose of the unit properly and in accordance with applicable national, regional and local laws.

Packaging



Dispose of the packaging material in an environmentally responsible manner.

- Note current disposal routes.
- Keep the packing materials out of the reach of children.



3 Overview

3.1 Scope of delivery

The following items are included in the scope of delivery (possible variations due to country-specific requirements and/or import regulations):

Product name	Article number
P2B 304 Compressor station	
400 V	1036100100

- Pressure vessel
- Compressor unit
- Fabric reinforced hose
- Hose nozzle
- Installation and Operating Instructions
- Collector tray

3.2 Special accessories

The following optional items can be used with the device:

Pressure reducer.	6040-992-00
---------------------------	-------------

3.3 Wear parts and spare parts

The following working parts need to be changed at regular intervals (refer to the "Maintenance" section):

Product name	Article number
Air intake filter	9000-416-50
Vibration damper set.	0880100020

4 Technical data

Electrical data		1036100100	
Electrical frequency	Hz	50	60
Voltage	V	400	400
Rated power	kW	4.4	6.0
Nominal current at 8 bar (0.8 MPa)	A	8.8	9.6
Motor protection switch, recommended setting	A	4.4	5.0
Speed	min ⁻¹	1440	1700
Type of protection		IP X4	IP X4
Mains fusing	A	10 **	10 **
Mains connection	CEE 16 A 3L + N + PE, PVC hose connection 5 x 1.5 mm ² ; length: 2.5 m;		

** Circuit breaker fuse characteristics B, C or D in accordance with DIN EN 60898

General technical data			
Pressure vessel volume	l	90	90
Delivery at 5 bar (0.5 MPa)	l/min	430	480
Pressure build-up phase 0 - 7.5 bar (0 - 0.75 MPa) approx.	s	90	80
Duty cycle	%	100	100
Initial pressure/Cut off pressure	bar (MPa)	6.5 / 8.5 (0.65 / 0.85)	6.5 / 8.5 (0.65 / 0.85)
Safety valve, maximum permissible operating pressure	bar (MPa)	10 (1)	10 (1)
Pressure dew point (at 7 bar / 0.7 MPa)	°C	≤ +5	≤ +5
Dimensions (W x H x D)	cm	102 x 76 x 62	102 x 76 x 62
Weight	kg	143	143
Noise level	dB(A)	74	77

Ambient conditions during storage and transport

Temperature	°C	-10 to +55
Relative humidity	%	max. 95

Ambient conditions during operation

temperature	°C	+5 to +40
Ideal temperature	°C	+10 to +25
Relative humidity	%	Max. 95

4.1 Declaration of conformity for machines in accordance with the 2006/42/EC Directive

We hereby declare that the unit described below conforms to all requirements of the machine directive 2006/42/EC.

The unit named below fulfills the requirements of the following directives:

- Electromagnetic Compatibility (EMC) Directive 2014/30/EU
- Low voltage directive 2014/35/EC
- Simple pressure vessel directive 2014/29/EU
- The assembly contains a pressure units covered by directive 2014/68/EC in its current version.
- RoHS directive 2011/65/EU

Manufacturer's name:	Dürr Technik GmbH & Co. KG
Manufacturer's address:	Pleidelsheimer Straße 30 D-74321 Bietigheim-Bissingen

Reference number:	1036
Article designation:	Oil-free compressor station P2B 304
From the serial number:	H400000

We hereby declare that the unit may only be commissioned once it has been established that the machine into which this unit is to be installed complies with the provisions as set out in Machinery Directive 2006/42/EC.

Bietigheim-Bissingen, 20/04/2016

Andreas Ripsam
Executive Board of Dürr Technik

Proof of signature in the
Original document held by Dürr Technik

4.2 Type plate

Complete system

The type plate for the complete system is located on the pressure vessel of the unit.

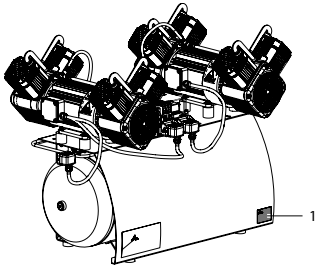

1 Type plate for the complete system

Compressor unit

The type plate of the compressor unit is located on the crankcase below the cylinder.

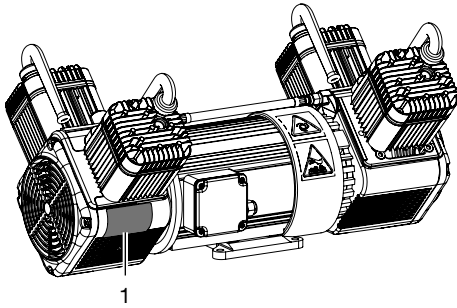

1 Compressor unit type plate

5 Operation

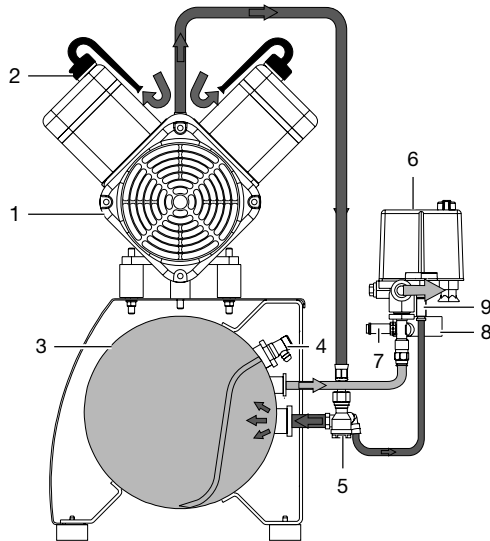

- 1 Compressor unit
- 2 Air intake filter
- 3 Pressure vessel
- 4 Condensate drain valve
- 5 Check Valve
- 6 Pressure switch
- 7 Safety Valve
- 8 Pressure gauge / display
- 9 Pressure relief valve

The compressor unit draws in atmospheric air and compresses it without oil. The oil-free compressed air is then transported directly to the pressure tank. The oil-free and hygienic air is made available to the consumers in the pressure tank.



6 Requirements

6.1 Installation/setup room

The room chosen for set up must fulfil the following requirements:

- Closed, dry, well-ventilated room
- Should not be a room made for another purpose (e. g. boiler room or wet cell)



NOTICE

Risk of overheating due to insufficient ventilation

The units generates heat. Possibility of heat damage and/or reduced service life of the unit.

- › Do not cover the unit.
- › Install a fan for auxiliary ventilation in rooms where ambient temperatures exceed ≥ 40 °C while the unit is in operation.

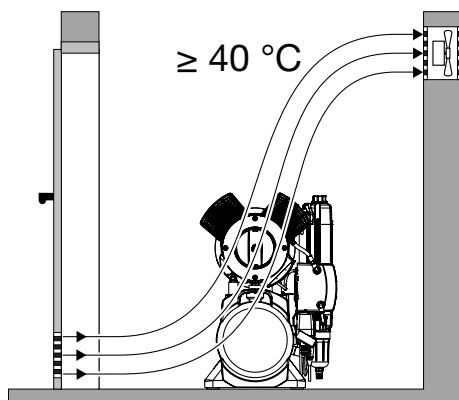

6.2 Setup

The following conditions must be taken into account for installation:



The air is filtered when it is sucked in. This does not alter the composition of the air. For this reason it is important to keep the sucked-in air free of harmful substances (e.g. do not suck in exhaust gases or contaminated exhaust air).

- Clean, level and sufficiently stable subsurface (note the weight of the unit).
- Type plate easy to read.
- Unit easy to access for operation and maintenance.
- Easy-to-access power outlet to which the unit is connected.
- Maintain sufficient distance to the wall (at least 20 cm).
- The compressed air pipe should be routed as closely as possible to the place of installation (note the length of the hose supplied).

6.3 Information about electrical connections

- › Ensure that the connection to the mains power supply is established in accordance with current valid national and local regulations and standards governing the installation of low voltage units.
- › Observe the current consumption of the unit to be connected.

7 Transport



WARNING Risk of explosion of the pressure tank and pressure hoses

- › The pressure tank and the pressure hoses must be vented before they are stored or transported.
- › Protect the unit against moisture, dirt and extreme temperatures during transport ("4 Technical data").
- › Always make sure that the condensate collector chamber is empty before transporting the unit ("9.3 Condensed water").
- › Always transport the unit in an upright position.
- › Only transport the unit using the transport handles provided.
- › Check the unit for transport damage.

7.1 Remove the transport locks

The unit is securely protected with two foam blocks and a retaining strap for safe transport.



- › Cut and remove the retaining strap.
- › Remove the foam blocks.
- › Check the unit for damage in transit.

8 Installing the compressor unit

For weight reasons the unit is not supplied fully assembled. Instead, the compressor units are installed at the site of use.

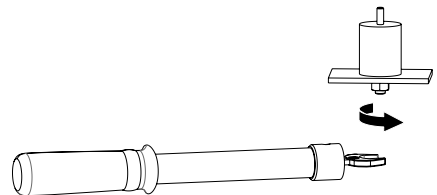
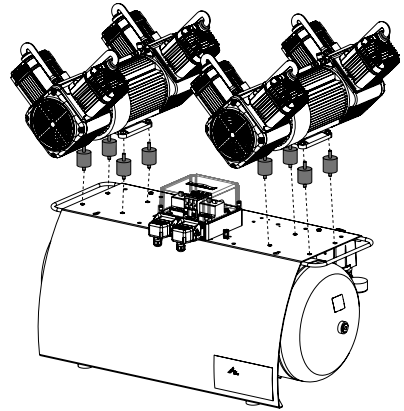
- › Set up the pressure vessel at the planned installation site
- › Screw in the vibration dampers into the motor mounting. Comply with the tightening torque (see table).



Hexagonal nut dimensions	 Width across flats	 Tightening torque
M4	SW 7	3 Nm
M5	SW 8	6 Nm
M6	SW 10	9 Nm
M8	SW 13	20 Nm

- › Place the compressors on the vibration dampers.
- › Attach the vibration dampers to the motor base of the compressor.
- › **Attachment to the compressor motor base**
- › Mount the vibration dampers (2) with the lock washer (3) and the hexagonal nut (4) on the

motor base (10) as shown in the assembly overview.



NOTICE
Rotation of the vibration dampers causes increased wear.

The service life of the vibration dampers is reduced.

- › When tightening the screws, ensure that the rubber of the vibration dampers does not become twisted.

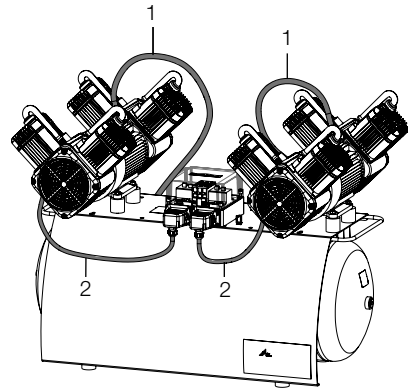
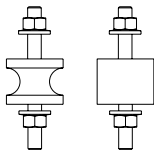
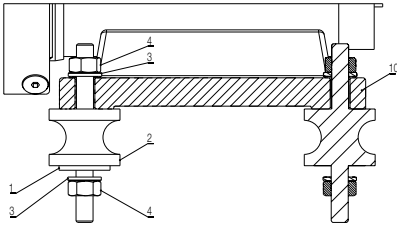

- 1 Compressed air hose
- 2 Electrical connection

- › Plug in the electrical connections of the compressor units at the control box. Connect the left-hand unit to the left-hand plug connector and the right-hand unit to the right-hand plug connector. Close the lock on the connector housing.

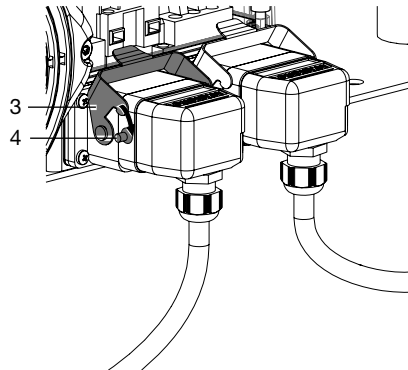

- 3 Lock
- 4 Pin connector housing

8.1 Connect the compressor

- › Insert the compressed air connections from the pressure vessel to the compressor.

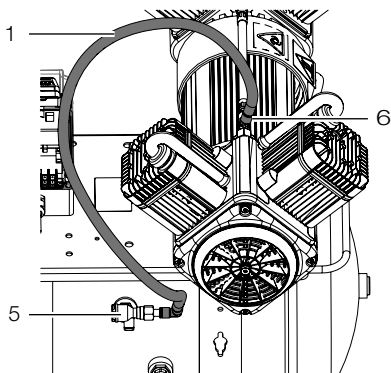

- 1 Compressed air hose
- 5 Compressed air connection on the vessel
- 6 Compressor compressed air connection



9 Installation

9.1 Establishing the compressed air connection



The devices are designed as standard for a nominal pressure of 7 bar. Exceeding the nominal pressure on a regular basis will reduce the service life of the device.

The unit is equipped as standard with a control gear, which consists of a pressure switch, pressure gauge, safety valve, non-return valve and condensate drain.

In order to avoid the transfer of vibrations, we recommend installing a flexible pressure hose between the pressure hose and the pressure switch. A pressure reducer can also be connected.

- › The compressed-air supply is connected to the quick-release coupling (incl. hose adapter piece) or to the pressure switch by means of a G 1/4" internal thread.
- › Secure the pressure hose to the hose adapter piece using a hose clip.
- › Connect the hose adapter piece to the quick-release coupling.

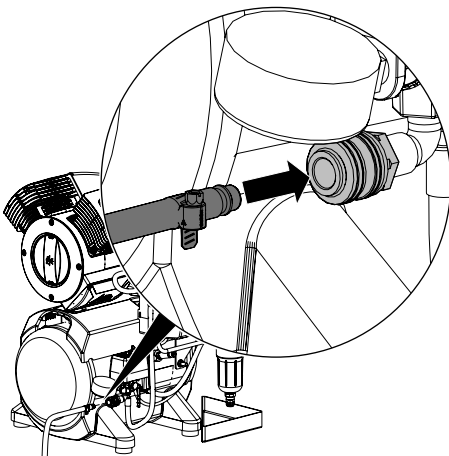

9.2 Pressure reducer

- › Insert the pressure reducer into the quick release coupling.
- › Insert the pressure hose into the quick release coupling on the pressure reducer.

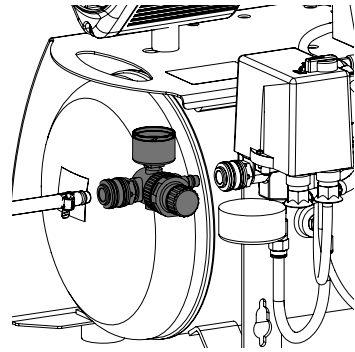

9.3 Condensed water

When air from the surrounding atmosphere is compressed, different amounts of condensate will accumulate in the pressure vessel depending on the humidity and temperature of the air. The condensate must be let off in regular intervals:

- › Place a collector tray under the condensate drain.
- › Open the condensate drain valve at maximum tank pressure.
- › Close the condensate drain valve as soon as all of the condensate has been blown out.

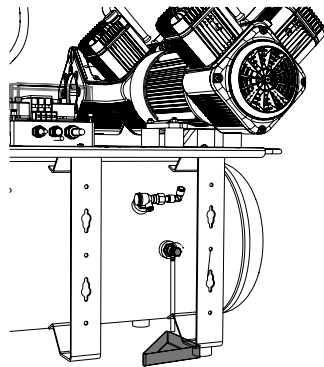

9.4 Electrical connections

Electrical safety when making connections



The unit has no main power switch. For this reason it is important that the unit is be set up in such a way that the plug can be easily accessed and unplugged if required.

- › The unit must only be connected to a correctly installed power outlet.
- › Make sure that none of the electrical cables leading to the unit are under any mechanical tension.
- › Before initial start-up check that the mains supply voltage and the voltage stated on the type plate match (see also "4. Technical data").

Establishing the electrical connections



DANGER

Risk of electric shock due to defective mains cable

- › Mains cables must not be allowed to come into contact with any hot surfaces on the unit.
- › Plug the mains plug into an earthed power outlet.

10 Commissioning and first start-up

10.1 Check the motor protection switch

After compressor assembly, check the motor protection switch and adjust if required. It was set to the recommended setting in the factory (see "4 Technical data").

- › Switch on the device at the pressure switch by rotating the switch to the "I" position.

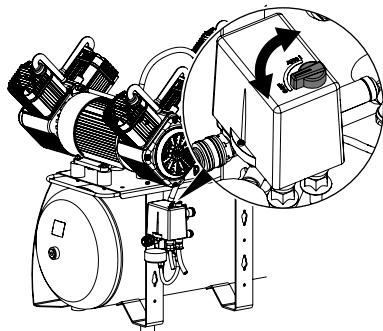

- › Measure the maximum current consumption (this is the value just before the cut-off pressure is reached).

If the reading deviates from the recommended setting then the motor protection switch needs to be adjusted (see "10.5 Adjustment options").

10.2 Checking the switch-on/cut-off pressure

The switch-on/cut-off pressure is preset at the factory. Check the setting during first start-up.

- Switch on the unit at the pressure switch by rotating it to the position "I AUTO".
- Read off the cut-off pressure from the pressure gauge.
- Drain the air from the pressure tank (e.g. via the condensate drain valve) until the unit starts and then close it again.
- Read off the pressure when the unit switches on.

If the readings deviate from the values preset at the factory, adjust the pressure switch to the factory settings.

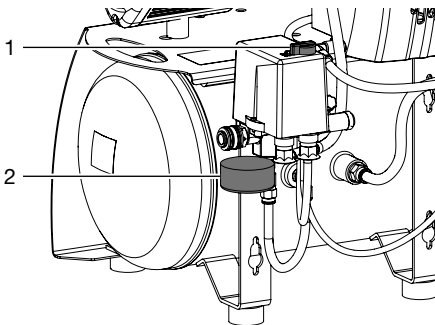

- 1 On/off switch
- 2 Pressure gauge

10.3 Checking the safety valve

Check for the correct operation of the safety valve upon commissioning the device and then at regular intervals.

-  The safety valve is factory set to 10 bar (1 hPa) and has been checked and stamped.



DANGER

Risk of explosion of the pressure vessel and pressure hoses

- Do not change the safety valve settings.

- Switch on the unit at the pressure switch and fill the pressure vessel to the cut-off pressure.



WARNING

Risk of damage to the safety valve

Risk of explosion of the pressure vessel and pressure hoses due to a defective safety valve

- Do not use the safety valve to vent the pressure vessel.

- To open, rotate the safety valve screw anti-clockwise until the valve begins to blow off. Only allow the safety valve to blow for a short period.
- Then turn the screw clockwise as far as it will go to close the valve. The valve must now be closed again.

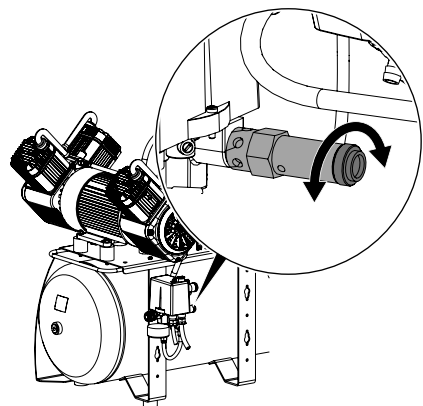

10.4 Adjusting the rate of flow at the pressure reducer

The pressure reducer regulates the rate of flow in the system and adjusts it to the required operating pressure. In order to adjust the rate of flow, air needs to be extracted via a consumer.

- › Activate the air consumer unit.
- › Lift the rotary knob at the pressure reducer.
- › Adjust the rate of flow via the rotary knob.
 - Turn the knob in the "+" direction to increase the rate of flow.
 - Turn the knob in the "-" direction to reduce the rate of flow.
- › Press in the rotary knob until it engages and cannot be adjusted.

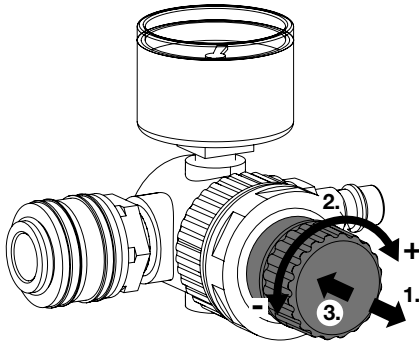

10.5 Adjustment options

Adjusting the pressure switch



WARNING Risk of explosion of the pressure vessel

The pressure vessels used in the compressors are designed to withstand continuous pressure changes of 2 bar and can be used continuously under these pressure changes.

- › For load changes > 2 bar (max. permissible: 3 bar), comply with the maximum load change cycles specified in the operating instructions of the pressure vessel.



DANGER Exposed live parts

- Risk of electric shock due to live parts
 - › Disconnect all power from the device.
 - › Use insulated tools.
 - › Do not touch live parts.



The cut-off pressure must be at least 0.5 bar (0.05 hPa) below the maximum pressure of 10 bar (1 hPa) of the safety valve. Otherwise the safety valve can open too early, which will prevent the compressor unit from attaining the cut-off pressure, as a result of which it will run continuously. The maximum permitted pressure is marked by a red line on the attached pressure gauge.

If the read-off values differ from the factory settings or if other settings are required, the cut-off pressure of the compressor can be adjusted at the adjusting screw on the pressure switch. The start-up pressure can then be adjusted using the pressure difference Δp .

- › Take off the pressure switch cover.
- › Adjust the cut-off pressure P at the adjustment screw.

The cut-off pressure increases in the "+" arrow direction and decreases in the "-" arrow direction. The pressure difference Δp is also influenced by this adjustment.

- › Adjust the start-up pressure via the pressure difference Δp at the adjustment screw.

The pressure difference increases in the "+" arrow direction and decreases in the "-" arrow direction.

The maximum permissible pressure difference must not be set to more than 3 bar.

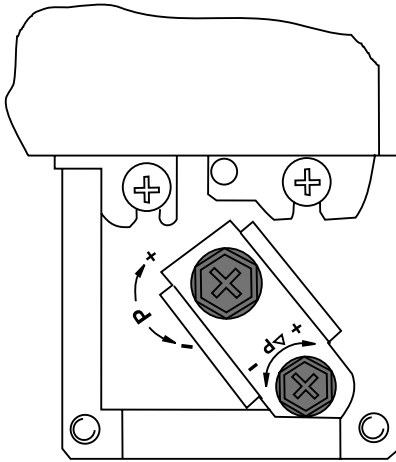

motor protection switch, see "4 Technical data").

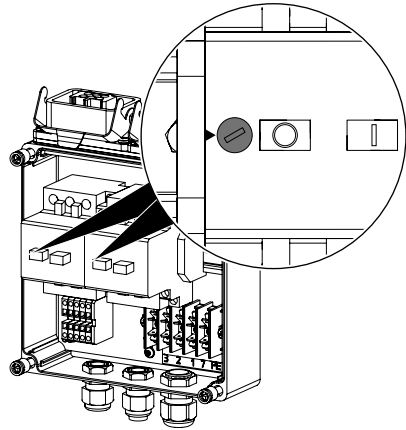

EN

Adjusting the motor protection switch

Pressure switch

- › Take off the pressure switch cover.
- › Adjust the motor protection switch to the measured value using the setting screw (observe the range between the min. and max. permissible settings of the motor protection switch, see "4 Technical data").

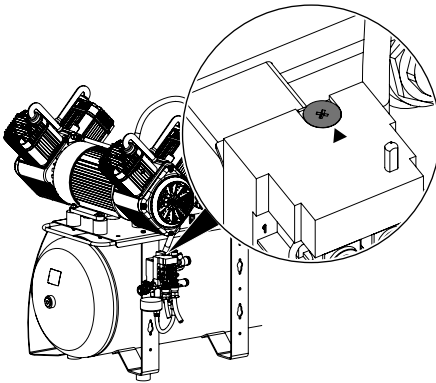

Controller

- › Remove the cover from the controller.
- › Adjust the motor protection switch with the adjustment screw to the measured value (observe the range between the MIN permissible setting and the MAX permissible setting of the

11 Circuit diagrams

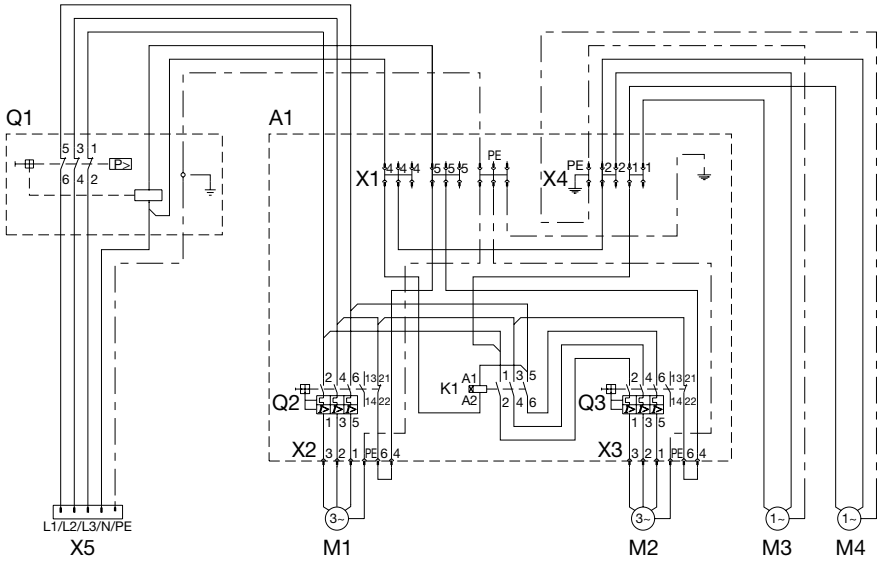

- X5 Mains connection 3/N/PE AC 230 V
- Q1 Pressure switch
- A1 Control box
- X1 Distributor rail
- X2 Compressor plug connection
- X3 Compressor plug connection
- X4 Distributor rail
- Q2 Motor protection switch
- Q3 Motor protection switch
- K1 Time-lag relay
- M1 Compressor unit
- M2 Compressor unit
- M3 Fan motor, membrane drying unit (optional)
- M4 Fan motor, membrane drying unit (optional)



12 Operation



De-energise the unit prior to working on it or in the event of potential danger (e. g. pull the mains plug) and prevent it from being switched back on again.

12.1 Switching the unit on/off

- › Switch on the device at the pressure switch by rotating it to the "I AUTO" position.
The compressor unit will start up automatically and fill the pressure vessel. When the cut-off pressure is reached, the compressor unit switches itself off automatically.
- › The device can be switched off as required by turning the pressure switch to the "0 OFF" position.

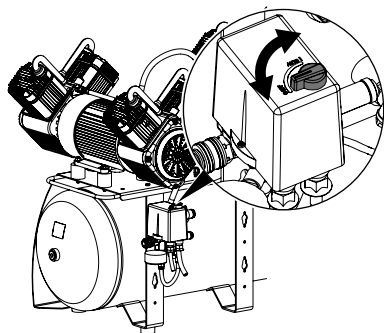

12.2 Taking out of use

If the unit is not to be used for a prolonged period of time, we recommend that it is properly shut down and taken out of use.

To do this, the accumulated condensation water from the unit must be drained.

- › Switch on the unit and wait until the cut-off pressure is reached.

Pressure tank

- › Switch off the unit.
- › Disconnect the mains plug.
- › Relieve the full pressure from the compressed air vessel (e.g. using a blow-off gun connected to the quick-release coupling or via the condensate drain valve (if present)).
- › Disconnect the compressed air connection on the quick release coupling.

Storage of the unit



WARNING

Risk of explosion of the pressure tank and pressure hoses

- › The pressure tank and the pressure hoses must be vented before they are stored or transported.
- › Protect the unit against moisture, dirt and extreme temperatures during transport (refer to the section on "Ambient conditions").
- › Only store the unit when it has been completely emptied.

13 Maintenance

13.1 Maintenance schedule



NOTICE
Risk of damage to the unit due to blocked filters

Continuous running due to reduced delivery. Damage to the unit due to burst filters.
 > Replace filters in accordance with the maintenance schedule.

EN

Maintenance interval	Maintenance work
At regular intervals	> Drain the condensate from the pressure vessel by opening the condensate drain valve (the interval can vary depending on the ambient conditions and method of working; empty it daily with high air humidity).
Annually	> Replace the air intake filter - every six months given a high concentration of dust.
Every 4 years	> Replace the vibration dampers.
In accordance with national law	> Check the safety valve. > Performance of recurring safety inspections (e.g. pressure container inspections, electrical safety inspections) in accordance with applicable national laws.

13.2 Replacing the air intake filter

- › Switch off the compressor at the pressure switch.
- › Pull off the noise reducer from the air intake filter.
- › Remove the air intake filter.
- › Insert a new air intake filter.
- › Push on the noise reducer onto the air intake filter.

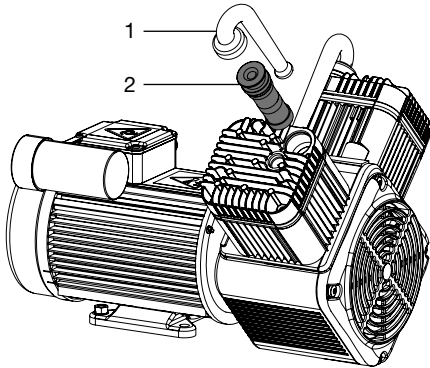

- 1 Noise reducer
- 2 Air intake filter



14 Tips for operators and service technicians



Any repairs above and beyond routine maintenance must only be carried out by suitably qualified personnel or by one of our service technicians.



De-energise the unit prior to working on it or in the event of potential danger (e. g. pull the mains plug) and prevent it from being switched back on again.

Fault	Probable cause	Solution
Compressor will not start	No mains voltage	› Check the mains fuse; if necessary, switch the circuit breaker back on. If the fuse is defective, replace it.
	Undervoltage or overvoltage	› Measure the mains voltage; call an electrician if necessary.
	Pressure switch not switched on	› Switch on the pressure switch. › Inform a service technician.
	Motor winding overheating protector tripped (overheating)	› Allow the unit to cool down.
The compressor does not switch off	The compressor is too small, air intake too high	› Calculate the amount of air required and install a larger compressor if necessary.
	Leakage in the compressed air system	› Locate and seal the leakage. › Inform a service technician.
Compressor switches on from time to time even though no air is being taken for a consumer unit	Leak in the compressed air system	› Locate and seal the leak. › Inform a service technician.
Knocking or loud noises on the compressor	Compressor unit defective	› Disconnect all power from the device and inform a service technician.
Reduced delivery. The compressor requires longer to charge the pressure vessel, see charging times in "4 Technical data"	Air intake filter soiled	› Replace the air intake filter at least 1x per year. The air intake filter must never be cleaned.

15 Tips for service technicians



The following information about troubleshooting is intended solely for service technicians. Repairs must only be carried out by service technicians.



De-energise the unit prior to working on it or in the event of potential danger (e. g. pull the mains plug) and prevent it from being switched back on again.

Fault	Probable cause	Solution
Compressor will not start	No mains voltage. On three-phase units: one phase is missing or not connected (generation of a humming sound)	<ul style="list-style-type: none"> ➤ Check the mains fuse; if necessary, switch the circuit breaker back on. If the fuse is defective, replace it. Check the mains supply voltage.
	Undervoltage or overvoltage	<ul style="list-style-type: none"> ➤ Measure the supply voltage; call an electrician if necessary.
	Relief valve defective, unit starts against pressure	<ul style="list-style-type: none"> ➤ Check that the relief valve discharges after switching off the unit. Free up the movement of the relief valve operable or replace it.
	Mechanical sluggishness of a unit (piston is stuck); motor protection has tripped	<ul style="list-style-type: none"> ➤ Switch the unit off and disconnect it from the power supply, remove the fan hood from the blocked compressor and turn the fan wheel. If this is not possible, replace the piston and cylinder or the complete unit.
Humming noise from motor	Motor capacitor is defective	<ul style="list-style-type: none"> ➤ Replace the capacitor.



Service

Dürr Technik GmbH & Co. KG
74301 Bietigheim-Bissingen
Telephone 0 71 42 / 90 22 - 20
Fax 0 71 42 / 90 22 - 99
e-mail: service@duerr-technik.de

Replacement order

Telephone 0 71 42 / 9022 - 0
Fax 0 71 42 / 9022 - 99
e-mail: office@duerr-technik.de

The following information is required when ordering spare parts:

- Type designation and item number
- Order number as appears on the spare parts list
- Quantity required
- Exact shipping address
- Shipping information

Repairs/return delivery

Ensure that the unit is **depressurized** before transport! Use the original packaging when returning units, if possible. Always pack the units in a plastic bag. Use recyclable packing material.

Return delivery address:

Dürr Technik GmbH & Co. KG
Pleidelsheimer Straße 30
74321 Bietigheim-Bissingen
-Germany-

International addresses for Dürr Technik

www.duerr-technik.com

Dürr Technik GmbH & Co. KG
Pleidelsheimer Strasse 30
74321 Bietigheim-Bissingen
Germany
Fon: +49 7142-90 22 -0
www.duerr-technik.com
office@duerr-technik.de

