

Gas recovery pump MEX 0544

EN



PTB 04 ATEX 4002



II 1/2G c d IIA T3 X
II G IIA

Installation and Operating Instructions



0544100100L02



1608V001

Contents



Important information

1 About this document	2
1.1 Warnings and symbols	2
1.2 Copyright information	2
2 Safety	3
2.1 Intended use	3
2.2 Improper usage	3
2.3 General safety information	3
2.4 Safety rules for gas recovery pumps	3
2.5 Qualified personnel	4
2.6 Protection from electric shock	4
2.7 Only use genuine parts	4
2.8 Transportation and storage	4
2.9 Disposal	4



Product description

3 Overview	5
3.1 Scope of delivery	5
3.2 Spare parts and accessories	5
4 Technical data	6
4.1 Dimensions, type K	6
4.2 Technical data, type K	8
4.3 Technical data, type K	9
4.4 Technical data, type K	10
4.5 Technical data, type K	11
4.6 Technical data, type K	12
4.7 Technical data, type K	13
4.8 Technical data, type K	14
4.9 Dimensions, type G	15
4.10 Technical data, type G	17
4.11 Technical data, type G	18
4.12 Technical data, type G	19
5 Volumetric flow rate characteristic curve	20
6 Declaration of conformity	21
6.1 EU declaration of conformity in accordance with ATEX directive 2014/34/EU	21



Installation

7 Requirements	23
8 Vibrations	23
9 Installation position and fastening	24
10 Installation	25
10.1 Electrical installation	25
10.2 Motor protection	26
10.3 Direction of rotation	26
10.4 Flame arrestor and line connections	26



Operation

11 Operation	27
12 Maintenance	27
12.1 Maintenance schedule	27
12.2 Cleaning	28
12.3 Flame arrestor	28
12.4 Checking the coupling	28
12.5 Replacing the motor/pump	29
13 Taking the unit out of use	29



Troubleshooting

14 Tips for operators and service technicians	30
--	----



Addresses



Important information

1 About this document

These installation and operating instructions represent a part of the unit. They correspond to the relevant version of the unit and the status of technology valid at the time of its market launch.



In the event that the instructions and notes in these installation and operating instructions for are not observed, Dürr Technik accepts no warranty or liability of any kind for the safe operation and reliable function of the units.

This translation was prepared to the best of our knowledge. The original German language version of the manual is the definitive version. Dürr Technik is not liable for translation errors.

1.1 Warnings and symbols

Warnings

The warnings in this document are intended to draw your attention to possible injury to persons or damage to machinery.

The following warning symbols are used:



General warning symbol



Warning – dangerous high voltage



Warning – hot surfaces



Warning - automatic start-up of the unit

The warnings are structured as follows:



SIGNAL WORD

Description of the type and source of danger

Here you will find the possible consequences of ignoring the warning

- › Follow these measures to avoid the danger.

The signal word differentiates between four levels of danger:

- **DANGER**
Immediate danger of severe injury or death
- **WARNING**
Possible danger of severe injury or death
- **CAUTION**
Risk of minor injuries
- **NOTICE**
Risk of extensive material/property damage

Other symbols

These symbols are used in the document and on or in the unit:



Note, e.g. specific instructions regarding efficient and cost-effective use of the unit.



Comply with the specification in the accompanying documents.



CE labelling



Date of manufacture



Observe the fitting installation position of the pump.



Dispose of the unit properly and in accordance with applicable national, regional and local laws.



Switch off and de-energise the device (e. g. unplug from mains).

1.2 Copyright information

All names of circuits, processes, names, software programs and units used in this document are protected by copyright.

The reprinting of the installation and operating instructions, even in extracts, is only permitted with the written permission of Dürr Technik.

2 Safety

Dürr Technik has developed and constructed the units in such a way that danger is to a large extent excluded if the units are used as intended. Nevertheless, residual risks can remain. You should therefore observe the following notes.

2.1 Intended use

The unit is suitable for the aspiration of gas/vapour/air mixtures that may be potentially explosive. The unit can be used, for example, for the aspiration of fuel vapour/air mixtures in fuel dispensers.

Permissible ambient temperature -40°C to +60°C.



CAUTION

The combustible gases or fluids occurring in operation must belong to explosion group IIA with a maximum experimental safety gap > 0.9 mm

The unit is designed for use with a plant or a machine. It must only be put into operation when the manufacturer of the plant or machine in which the unit is installed has ensured that all requirements necessary to guarantee safe operation have been satisfied.

The gas recovery pumps must be electrostatically earthed. The flame arresters (and the components surrounding them) should be visually inspected at appropriate intervals, in particular for contamination and corrosion. Where necessary they should be cleaned or replaced. The ambient temperature and the temperature at the inlet must not exceed +60 °C.

The operational overpressure in the outlet line in relation to atmospheric pressure must not exceed 150 mbar (150 hPa).

When using the gas recovery pumps as a protection system, the following additional requirements must also be satisfied:

Max. hose and pipe length between the dispensing valve and the gas recovery pump

1. Gas recovery hose with an internal diameter ≤ 10 mm in a coaxial hose ≤ 10 m together with a downstream pipe DN 15 (G1/2"), length ≤ 3 m
or
2. Coaxial hose with an external diameter ≤ 38 mm, length ≤ 6 m together with a downstream pipe DN 15 (G1/2"), length ≤ 3 m

3. In addition, the following vessels may be installed in the pipe on the suction side:

- a Pulsation damper 250 ml from Scheidt & Bachmann, no. 0582542, or
- b Condensation separator from Fafnir, no. XO 013001.

The vessels are to be installed at a distance of between 0.3 m and 2.5 m upstream of the gas recovery pump. The minimum pipe length between the hose and the vessel must be 0.5 m.

2.2 Improper usage

Any other usage or usage beyond this scope is deemed to be improper. The manufacturer accepts no liability for damage resulting from such use. In such cases, the user/operator will bear the sole risk.



WARNING

Serious injury and material damage due to improper usage

- › Conveying explosive mixtures in any way other than that specified is not permitted.

2.3 General safety information

- › When operating this unit, always observe all directives, laws, and other rules and regulations applicable at the site of operation.
- › Check the function and state of the unit prior to each use.
- › Do not convert or modify the unit.
- › Comply with the specifications of the Installation and Operating Instructions.
- › Ensure that the unit operator has access to the Installation and Operating Instructions at all times.

2.4 Safety rules for gas recovery pumps

The following rules and directives must be followed when working with or on the gas recovery pump.

– EN 60079-0 (IEC 60079-0)

Electrical apparatus for potentially explosive atmospheres - General requirements.

– EN 60079-10 (IEC 60079-10)

Electrical apparatus for explosive gas atmospheres Part 10: Classification of hazardous areas.

– **EN 60079-14 (IEC 60079-14)**

Electrical apparatus for explosive gas atmospheres - Part 14:Electrical installations in hazardous areas.

– **EN 13617-1**

Petrol filling stations.Part 1: Safety requirements for construction and performance of metering pumps, dispensers and remote pumping units.

- Country-specific safety directives.
- Country-specific environmental directives.
- Country-specific occupational health and safety regulations.
- Leaflet from TÜV Rheinland:Monitoring of gas recovery systems.
- **If appropriate, other country-specific regulations and guidelines.**

2.5 Qualified personnel

Operation

Unit operators must ensure safe and correct handling based on their training and knowledge.

- › Instruct or have every operator instructed in the handling of the unit.

Installation and repairs

- › Always arrange for any assembly work, readjustments, alterations, extensions, and repairs to be performed by Dürr Technik or by personnel authorised and trained by Dürr Technik. Qualified personnel are defined as those trained by Dürr Technik; who are familiar with the unit technology; and are aware of the dangers presented by the unit.

2.6 Protection from electric shock

- › When working on the units observe all the relevant electrical safety regulations.
- › Immediately replace any damaged cables or plugs.

2.7 Only use genuine parts

- › Only use accessories and special accessories that are specified or approved by Dürr Technik.
- › Only use original working and spare parts.

 Dürr Technik accepts no liability for damage resulting from the use of non-approved accessories, special accessories or any working parts or spare parts other than original parts.

2.8 Transportation and storage

The unit is delivered in a cardboard box filled with packing material. The original packaging provides optimum protection for the unit during transport. Wherever possible, always use the original packaging for transport and storage of the unit.

- Keep the packing materials out of the reach of children.



NOTICE

Risk of corrosion of the unit

Moisture can lead to corrosion.

- › Protect the unit from moisture during transportation.

The unit may be stored in its original packaging

- in warm, dry and dust-free rooms;
- protected from contaminants.



If possible, retain the packaging material.

Ambient conditions during storage and transport

Ambient conditions during storage and transport

Temperature	°C	-40 to +60
Relative humidity	%	10 % to 90 %

Please refer to the labels on the packaging padding.

2.9 Disposal

Unit



Dispose of the unit properly and in accordance with applicable national, regional and local laws.

Packaging



Dispose of the packaging material in an environmentally responsible manner.

- Note current disposal routes.
- Keep the packing materials out of the reach of children.



3 Overview

3.1 Scope of delivery

The following items are included in the scope of delivery (possible variations due to country-specific requirements and/or import regulations):

Gas recovery pump MEX 0544

The gas recovery pump MEX 0544 complete consists of:

- Motor
- Fan assembly with coupling
- Pump
- Installation and Operating Instructions

3.2 Spare parts and accessories

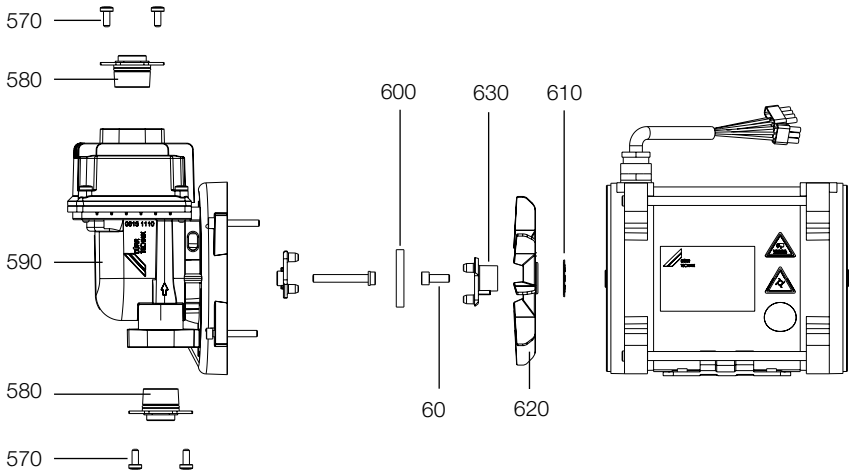

Figure 1: Spare parts for gas recovery pump MEX 0544 xxxx

Item no.	Name of item	Order number
570	Fixing screws M5 x 15	—
580	Flame arrester G 1/4"	0615 0750
	Alternatively: Flame arrester G1/4" Ex	0544100049
590	Pump	—
600	Coupling (rubber element)	0608 0006
60, 600 - 630	Fixing screws, fan assembly with coupling	0608 0200



4 Technical data

4.1 Dimensions, type K

Item no. 0544 1xxxK

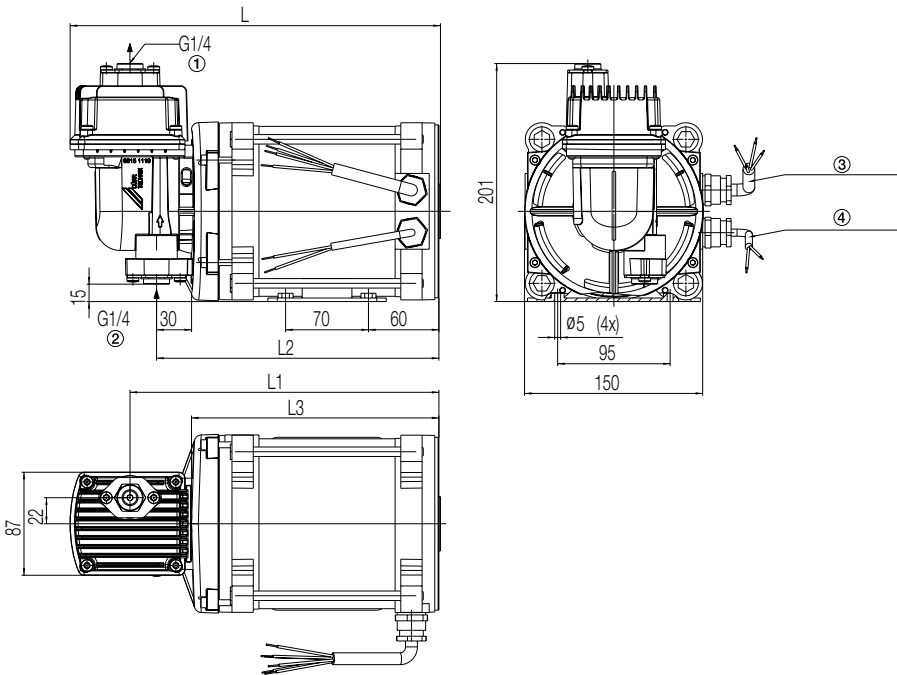

- ① Outlet
- ② Inlet
- ③ Cable
- ④ Cable for DC relay

EN

Item no. 0544 2xxxK

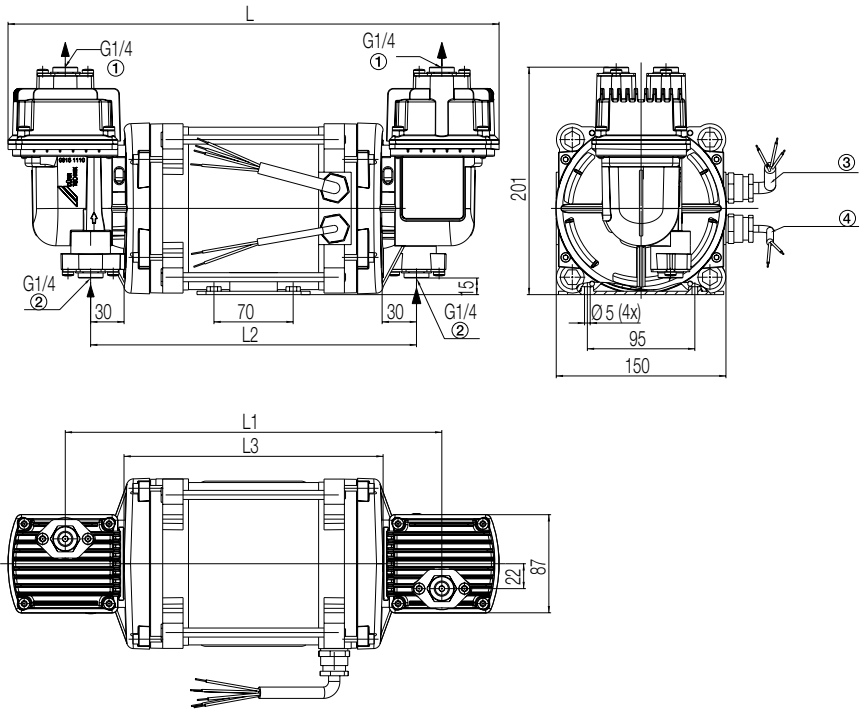

- ① Outlet
- ② Inlet
- ③ Cable
- ④ Cable for DC relay

4.2 Technical data, type K

Electrical data				
Article no.		0544 1000K	0544 1050K	0544 1070K
Electrical frequency	Hz	50	50	50
Nominal voltage	V	380-415	380-415	230/3~
Nominal current	A	0.75	0.75	1.2
Short-circuit current	A	5.0	5.0	
Relais		24 DC	24 DC	24 DC

General technical data				
Suction capacity $S_{\text{eff}}^{1)}$	l/min	53	53	53
End pressure P_{abs}	mbar	~150	~150	~150
Noise level	dB(A)	<70	<70	<70
Dimensions L	mm	312	312	311
Dimensions L1	mm	261	261	261
Dimensions L2	mm	238.5	238.5	238.5
Dimensions L3	mm	209	209	209
Remarks		-	Special motor mount	Special motor mount

¹⁾Flow rate per pump at back pressure $p_g=150$ mbar. Suction pressure $P_{\text{abs}}=900$ mbar.

Electrical data				
Type		0544 1100K	0544 1200K	0544 1230K
Electrical frequency	Hz	50	50	50
Nominal voltage	V	380-415	220-230	220-230
Nominal current	A	0.75	2.3	2.3
Short-circuit current	A	5.0	9.5	9.5
Relais		without	24 DC	24 DC

General technical data				
Suction capacity $S_{\text{eff}}^{1)}$	l/min	53	53	53
End pressure P_{abs}	mbar	~150	~150	~150
Noise level	dB(A)	<70	<70	<70
Dimensions L	mm	312	367	367
Dimensions L1	mm	261	316	316
Dimensions L2	mm	238.5	293.5	293.5
Dimensions L3	mm	209	264	264
Remarks		-	-	Special motor mount

¹⁾Flow rate per pump at back pressure $p_g=150$ mbar. Suction pressure $P_{\text{abs}}=900$ mbar.

4.3 Technical data, type K

Electrical data				
Article no.		0544 1250K	0544 1300K	0544 1400K
Electrical frequency	Hz	50	50	60
Nominal voltage	V	220-230	220-230	110-127
Nominal current	A	1.6	2.3	1.8
Short-circuit current	A	3.8	9.5	12
Relais		220-240 AC	without	24 DC

General technical data				
Suction capacity $S_{\text{eff}}^{1)}$	l/min	53	53	38
End pressure P_{abs}	mbar	~150	~150	~150
Noise level	dB(A)	<70	<70	<70
Dimensions L	mm	312	367	367
Dimensions L1	mm	261	316	316
Dimensions L2	mm	238.5	293.5	293.5
Dimensions L3	mm	209	264	264
Remarks		-	-	-

¹⁾Flow rate per pump at back pressure $p_e=150$ mbar. Suction pressure $P_{\text{abs}}=900$ mbar.

Electrical data				
Article no.		0544 1500K	0544 1600K	0544 1700K
Electrical frequency	Hz	60	50	50
Nominal voltage	V	110-127	380-415	380-415
Nominal current	A	1.8	0.75	0.75
Short-circuit current	A	12	5.0	5.0
Relais		without	24 AC	220-240 AC

General technical data				
Suction capacity $S_{\text{eff}}^{1)}$	l/min	38	53	53
End pressure P_{abs}	mbar	~150	~150	~150
Noise level	dB(A)	<70	<70	<70
Dimensions L	mm	367	312	312
Dimensions L1	mm	316	261	261
Dimensions L2	mm	293.5	238.5	238.5
Dimensions L3	mm	264	209	209
Remarks		-	-	-

¹⁾Flow rate per pump at back pressure $p_e=150$ mbar. Suction pressure $P_{\text{abs}}=900$ mbar.

4.4 Technical data, type K

Electrical data				
Article no.		0544 1800K	0544 1810K	0544 1900K
Electrical frequency	Hz	60	60	50
Nominal voltage	V	220	220	380-415
Nominal current	A	1.15	1.2	1.15
Short-circuit current	A	7.5	7.5	
Relais		without	220 AC	without

General technical data				
Suction capacity $S_{\text{eff}}^{1)}$	l/min	38	38	38
End pressure P_{abs}	mbar	~150	~150	~150
Noise level	dB(A)	<70	<70	<70
Dimensions L	mm	367	367	312
Dimensions L1	mm	316	316	261
Dimensions L2	mm	293.5	293.5	238.5
Dimensions L3	mm	264	264	209
Remarks		-	-	Special position of the pump heads

¹⁾Flow rate per pump at back pressure $p_g=150$ mbar. Suction pressure $P_{\text{abs}}=900$ mbar.

Electrical data				
Article no.		0544 2000K	0544 2050K	0544 2070K
Electrical frequency	Hz	50	50	50
Nominal voltage	V	380-415	380-415	230/ 3~
Nominal current	A	1.0	1.0	1.0
Short-circuit current	A	5.0	5.0	
Relais		24 DC	24 DC	24 DC

General technical data				
Suction capacity $S_{\text{eff}}^{1)}$	l/min	53	53	53
End pressure P_{abs}	mbar	~150	~150	~150
Noise level	dB(A)	<70	<70	<70
Dimensions L	mm	434	434	434
Dimensions L1	mm	333	333	333
Dimensions L2	mm	288	288	288
Dimensions L3	mm	229	229	229
Remarks		-	Special motor mount	Special motor mount

¹⁾Flow rate per pump at back pressure $p_g=150$ mbar. Suction pressure $P_{\text{abs}}=900$ mbar.

4.5 Technical data, type K

Electrical data				
Article no.		0544 2100K	0544 2200K	0544 2230K
Electrical frequency	Hz	50	50	50
Nominal voltage	V	380-415	220-230	220-230
Nominal current	A	1.0	3.0	3.0
Short-circuit current	A	5.0	9.5	
Relais		without	24 DC	24 DC

General technical data				
Suction capacity $S_{\text{eff}}^{1)}$	l/min	53	53	53
End pressure P_{abs}	mbar	~150	~150	~150
Noise level	dB(A)	<70	<70	<70
Dimensions L	mm	434	489	489
Dimensions L1	mm	333	388	388
Dimensions L2	mm	288	343	343
Dimensions L3	mm	229	284	284
Remarks		-	-	Special motor mount

¹⁾Flow rate per pump at back pressure $p_g=150$ mbar. Suction pressure $P_{\text{abs}}=900$ mbar.

Electrical data				
Article no.		0544 2300K	0544 2400K	0544 2500K
Electrical frequency	Hz	50	60	60
Nominal voltage	V	220-230	110-127	110-127
Nominal current	A	3.0	3.0	3.0
Short-circuit current	A	9.5	12	12
Relais		without	24 DC	without

General technical data				
Suction capacity $S_{\text{eff}}^{1)}$	l/min	53	38	38
End pressure P_{abs}	mbar	~150	~150	~150
Noise level	dB(A)	<70	<70	<70
Dimensions L	mm	489	489	489
Dimensions L1	mm	388	388	388
Dimensions L2	mm	343	343	343
Dimensions L3	mm	284	284	284
Remarks		-	-	-

¹⁾Flow rate per pump at back pressure $p_g=150$ mbar. Suction pressure $P_{\text{abs}}=900$ mbar.

4.6 Technical data, type K

Electrical data				
Article no.		0544 2600K	0544 2700K	0544 2750K
Electrical frequency	Hz	50	50	50
Nominal voltage	V	380-415	380-415	380-415
Nominal current	A	1.0	1.0	1.0
Short-circuit current	A	5.0	5.0	5.0
Relais		24 AC	220-240 AC	220-240 AC

General technical data				
Suction capacity $S_{\text{eff}}^{1)}$	l/min	53	53	53
End pressure P_{abs}	mbar	~150	~150	~150
Noise level	dB(A)	<70	<70	<70
Dimensions L	mm	434	434	434
Dimensions L1	mm	333	333	333
Dimensions L2	mm	288	288	288
Dimensions L3	mm	229	229	229
Remarks		-	-	Special position of the pump heads

¹⁾Flow rate per pump at back pressure $p_g=150$ mbar. Suction pressure $P_{\text{abs}} = 900$ mbar.

Electrical data				
Article no.		0544 2800K	0544 2810K	0544 2850K
Electrical frequency	Hz	60	60	60
Nominal voltage	V	220	220	220-230
Nominal current	A	1.7	1.7	1.2
Short-circuit current	A	7.5		
Relais		without	220 AC	24 DC

General technical data				
Suction capacity $S_{\text{eff}}^{1)}$	l/min	38	38	38
End pressure P_{abs}	mbar	~150	~150	~150
Noise level	dB(A)	<70	<70	<70
Dimensions L	mm	489	489	434
Dimensions L1	mm	388	388	333
Dimensions L2	mm	343	343	288
Dimensions L3	mm	284	284	229
Remarks		-	-	Special motor mount

¹⁾Flow rate per pump at back pressure $p_g=150$ mbar. Suction pressure $P_{\text{abs}} = 900$ mbar.

4.7 Technical data, type K

Electrical data		
Article no.	0544 2900K	
Electrical frequency	Hz	50
Nominal voltage	V	380-415
Nominal current	A	1.0
Short-circuit current	A	5.0
Relais		without

General technical data		
Suction capacity $S_{\text{eff}}^{1)}$	l/min	38
End pressure P_{abs}	mbar	~150
Noise level	dB(A)	<70
Dimensions L	mm	434
Dimensions L1	mm	333
Dimensions L2	mm	288
Dimensions L3	mm	229
Remarks		Special position of the pump heads

¹⁾Flow rate per pump at back pressure $p_g=150$ mbar. Suction pressure $P_{\text{abs}}=900$ mbar.

Electrical data				
Article no.		0544 1010K	0544100016	0544100018
Electrical frequency	Hz	50	50	50
Nominal voltage	V	380-415	380-415	230/400
Nominal current	A	0.75	0.75	1.2/0.75
Short-circuit current	A	5.0	5.0	5.0
Relais		24 DC	24 DC	24 DC

General technical data				
Suction capacity $S_{\text{eff}}^{1)}$	l/min	53	53	53
End pressure P_{abs}	mbar	~150	~150	~150
Noise level	dB(A)	<70	<70	<70
Dimensions L	mm	312	312	312
Dimensions L1	mm	261	261	261
Dimensions L2	mm	238.5	238.5	238.5
Dimensions L3	mm	209	209	209
Remarks		-	-	-

¹⁾Flow rate per pump at back pressure $p_g=150$ mbar. Suction pressure $P_{\text{abs}}=900$ mbar.

4.8 Technical data, type K

Electrical data		0544100017	0544 2060K	0544100019
Article no.				
Electrical frequency	Hz	50	50	50
Nominal voltage	V	220-230	380-415	380-415
Nominal current	A	2.3	1.0	0.75
Short-circuit current	A	5.0	5.0	5.0
Relais		24 DC	24 DC	24 DC

General technical data				
Suction capacity $S_{\text{eff}}^{1)}$	l/min	53	53	53
End pressure P_{abs}	mbar	~150	~150	~150
Noise level	dB(A)	<70	<70	<70
Dimensions L	mm	367	434	434
Dimensions L1	mm	316	333	333
Dimensions L2	mm	293.5	288	288
Dimensions L3	mm	264	229	229
Remarks		-	-	-

¹⁾Flow rate per pump at back pressure $p_{\text{e}}=150$ mbar. Suction pressure $P_{\text{abs}} = 900$ mbar.

Electrical data		0544100010	0544100021	0544100012
Article no.				
Electrical frequency	Hz	50	50	50
Nominal voltage	V	230/400	230/400	230/400
Nominal current	A	1.7/1.0	1.7/1.0	1.7/1.0
Short-circuit current	A	5.0	5.0	5.0
Relais		24 DC	24 DC	24 DC

General technical data				
Suction capacity $S_{\text{eff}}^{1)}$	l/min	53	53	53
End pressure P_{abs}	mbar	~150	~150	~150
Noise level	dB(A)	<70	<70	<70
Dimensions L	mm	434	434	434
Dimensions L1	mm	333	333	333
Dimensions L2	mm	288	288	288
Dimensions L3	mm	229	229	229
Remarks		-	-	-

¹⁾Flow rate per pump at back pressure $p_{\text{e}}=150$ mbar. Suction pressure $P_{\text{abs}} = 900$ mbar.

4.9 Dimensions, type G

Item no. 0544 1xxxG

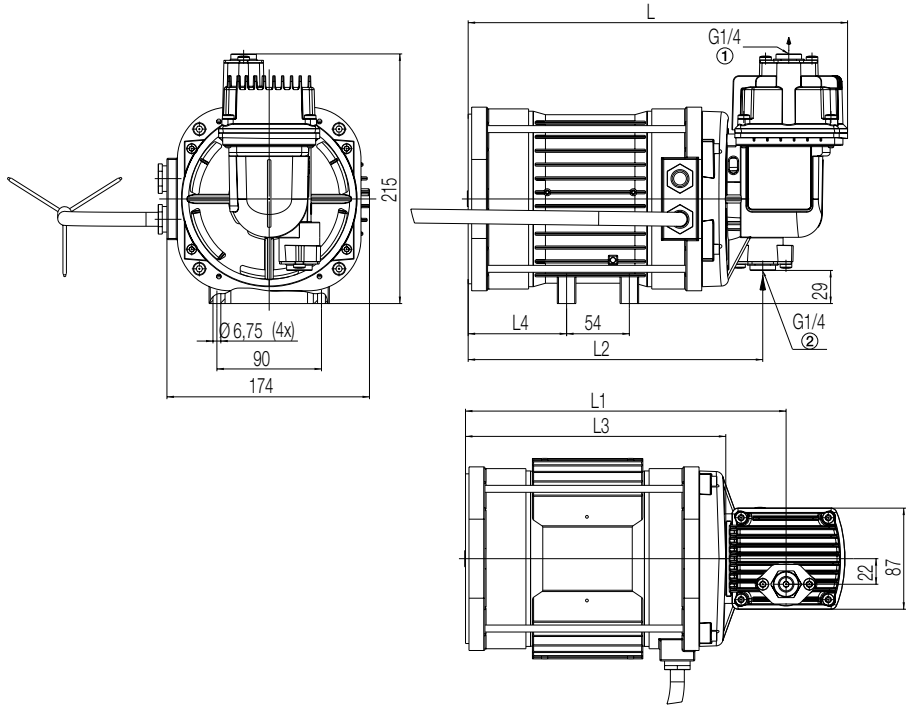

- ① Outlet
- ② Inlet

EN

Item no. 0544 2xxxG

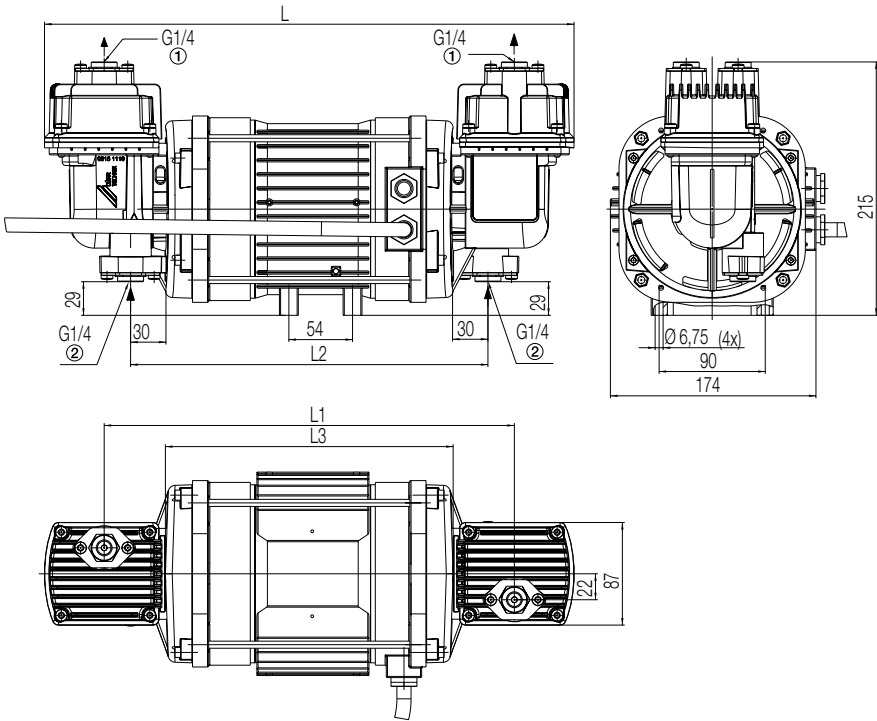

- ① Outlet
- ② Inlet

4.10 Technical data, type G

Electrical data				
Article no.		0544 1220G	0544 1250G	0544 1260G
Electrical frequency	Hz	50	50	50
Nominal voltage	V	220-240	220-240	220-240
Nominal current	A	1.5	1.5	1.5
Short-circuit current	A	10.5	10.5	10.5
Relais		230 AC	230 AC	230 AC

General technical data				
Suction capacity $S_{\text{eff}}^{1)}$	l/min	53	53	53
End pressure P_{abs}	mbar	~150	~150	~150
Noise level	dB(A)	<70	<70	<70
Dimensions L	mm	327	327	327
Dimensions L1	mm	276	276	276
Dimensions L2	mm	254	254	254
Dimensions L3	mm	224	224	224
Dimensions L4	mm	87	87	87
Remarks		Special position of the pump heads	-	-

¹⁾Flow rate per pump at back pressure $p_g=150$ mbar. Suction pressure $P_{\text{abs}} = 900$ mbar.

Electrical data				
Article no.		0544 1700G	0544 1710G	0544 1720G
Electrical frequency	Hz	50	50	50
Nominal voltage	V	380-415	380-415	380-415
Nominal current	A	0.75	0.7	0.7
Short-circuit current	A	4.7	4.7	4.7
Relais		230 AC	230 AC	230 AC

General technical data				
Suction capacity $S_{\text{eff}}^{1)}$	l/min	53	53	53
End pressure P_{abs}	mbar	~150	~150	~150
Noise level	dB(A)	<70	<70	<70
Dimensions L	mm	307	307	307
Dimensions L1	mm	256	256	256
Dimensions L2	mm	234	234	234
Dimensions L3	mm	204	204	204
Dimensions L4	mm	87	87	87
Remarks		-	-	Special position of the pump heads

¹⁾Flow rate per pump at back pressure $p_g=150$ mbar. Suction pressure $P_{\text{abs}} = 900$ mbar.

4.11 Technical data, type G

Electrical data				
Article no.		0544 2220G	0544 2250G	0544 2260G
Electrical frequency	Hz	50	50	50
Nominal voltage	V	220-240	220-240	220-240
Nominal current	A	2.85	2.85	2.85
Short-circuit current	A	10.5	10.5	10.5
Relais		230 AC	230 AC	230 AC

General technical data				
Suction capacity $S_{\text{eff}}^{1)}$	l/min	53	53	53
End pressure P_{abs}	mbar	~150	~150	~150
Noise level	dB(A)	<70	<70	<70
Dimensions L	mm	449	449	449
Dimensions L1	mm	348	348	348
Dimensions L2	mm	303	303	303
Dimensions L3	mm	239	239	239
Dimensions L4	mm	87	87	87
Remarks		Special position of the pump heads	-	-

¹⁾Flow rate per pump at back pressure $p_g=150$ mbar. Suction pressure $P_{\text{abs}} = 900$ mbar.

Electrical data				
Article no.		0544 2270G	0544 2700G	0544 2710G
Electrical frequency	Hz	50	50	50
Nominal voltage	V	220-240	380-415	380-415
Nominal current	A	2.85	1.1	1.1
Short-circuit current	A	10.5	4.7	4.7
Relais		230 AC	230 AC	230 AC

General technical data				
Suction capacity $S_{\text{eff}}^{1)}$	l/min	53	53	53
End pressure P_{abs}	mbar	~150	~150	~150
Noise level	dB(A)	<70	<70	<70
Dimensions L	mm	449	429	429
Dimensions L1	mm	348	328	328
Dimensions L2	mm	303	283	283
Dimensions L3	mm	239	219	219
Dimensions L4	mm	87	87	87
Remarks		Special position of the pump heads	-	-

¹⁾Flow rate per pump at back pressure $p_g=150$ mbar. Suction pressure $P_{\text{abs}} = 900$ mbar.

4.12 Technical data, type G

Electrical data		
Article no.	0544 2720G	
Electrical frequency	Hz	50
Nominal voltage	V	380-415
Nominal current	A	1.1
Short-circuit current	A	10.5
Relais		230 AC
General technical data		
Suction capacity $S_{\text{eff}}^{1)}$	l/min	53
End pressure P_{abs}	mbar	~150
Noise level	dB(A)	<70
Dimensions L	mm	429
Dimensions L1	mm	328
Dimensions L2	mm	283
Dimensions L3	mm	219
Dimensions L4	mm	87
Remarks		Special position of the pump heads

¹⁾Flow rate per pump at back pressure $p_g=150$ mbar. Suction pressure $P_{\text{abs}}=900$ mbar.

5 Volumetric flow rate characteristic curve

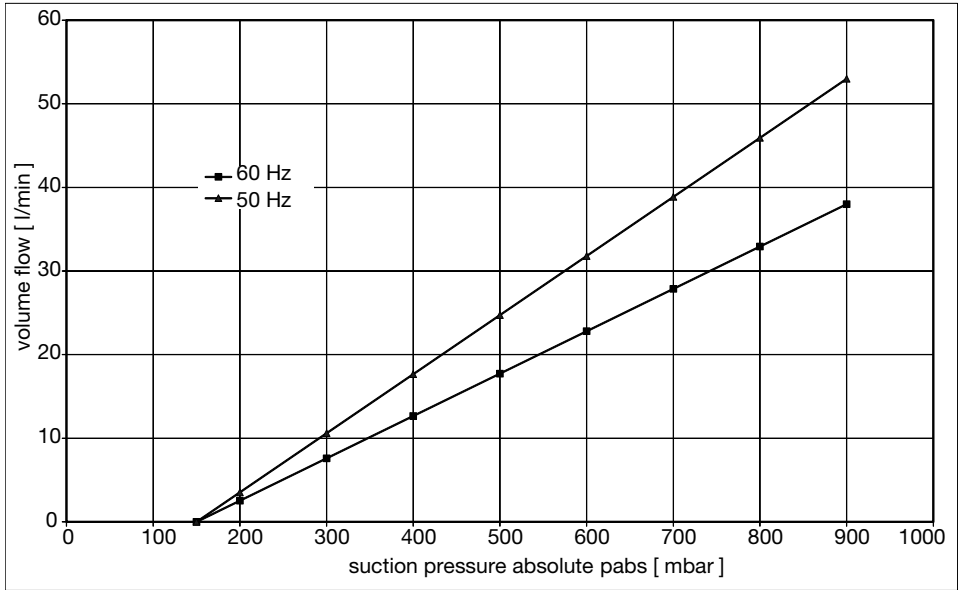

Figure 2: MEX 0544 xxxx volumetric flow rate characteristic curve

Volumetric flow rate per pump

Conveyed medium: Air

Back pressure p_e : 150 mbar at maximum flow rate

6 Declaration of conformity

6.1 EU declaration of conformity in accordance with ATEX directive 2014/34/EU



The unit named below fulfills the requirements of the following directives:

- ATEX directive 2014/34/EU
- Electromagnetic Compatibility (EMC) Directive 2014/30/EC

Manufacturer's name:	Dürr Technik GmbH & Co. KG
Manufacturer's address:	Pleidelsheimer Straße 30 D-74321 Bietigheim-Bissingen

Reference number:	0544 0000K to 0544 2999K 0544 0000G to 0544 2999G
Article designation:	Gas recovery pump MEX
From the serial number:	H400000

Description of the unit:	The gas recovery pumps of type "MEX" are piston pumps with integrated flame arresters on the inlet and outlet for the aspiration of explosive fuel vapour-air mixtures in gas recovery equipment of dispensing equipment at filling stations. The vacuum pumps run in intermittent operation.
Requirements for explosion protection of the unit:	Interior of the inlet and outlet lines: requirements in accordance with category 1 Environment of the vacuum pump: requirements in accordance with category 2
Description of the protection system:	The gas recovery pumps of the type "MEX" should also be used in the gas recovery lines as an explosion flame arrester or detonation flame arrester between the dispensing valve and the storage tank. This is to prevent flame transmission when there is an ignition at the dispensing valve when there is deflagration or stable detonation of potentially explosive vapour-air mixtures of the explosive group IIA under the following conditions: Downstream max. hose and tube length: <ol style="list-style-type: none"> 1. Gas recovery hose with an internal diameter ≤ 10 mm in a coaxial hose ≤ 10 m, or optionally, 2. Coaxial hose ≤ 6 m with an external diameter ≤ 38 mm, together with an inlet side pipe DN15 (G1/2") ≤ 3 m. On both the inlet and pressure side of the pumps there are flame arresters. The gas recovery pump can be used upstream of the feed in the gas accumulation line instead of a separate flame arrester (deflagration or detonation flame arrester).

ATEX:	EC Type Examination Certificate Number PTB 04 ATEX 4002
Notified body:	Physikalisch-Technische Bundesanstalt, Bundesallee 100 D-38116 Brunswick, ID no. 0102
Labelling:	Unit:  II 1/2G c d IIA T3 X Protection system:  II G IIA
Notified body for testing of the QA system	 0102

We hereby declare that the unit must not be commissioned until it has been established that the machine into which this unit is to be installed complies with the provisions as set out in ATEX Directive 2014/34/EU.

The PTB testing instructions "Requirements for explosion-proof vacuum pumps" have been applied in conjunction with the following harmonised and other standards:

- DIN EN 1127-1:2011-10
- DIN EN 13463-1:2009-07
- DIN EN 13463-3:2005-07
- DIN EN 13463-5:2011-10
- DIN EN 60034-1:2011-02
- DIN EN 60034-5:2007-09
- DIN EN 60079-0:2014-06
- DIN EN 60079-1:2015-04
- DIN EN ISO 16852:2010-09

Bietigheim-Bissingen, 05/07/2016

Andreas Ripsam
Executive Board of Dürr Technik

Proof of signature in the
Original document held by Dürr Technik



7 Requirements

The unit is intended for installation in machines. The following requirements must be satisfied:

- Set up/install the unit on a clean, level, and sufficiently stable surface (observe the weight of the unit).
- Set up or install the unit so that the type plate can be easily read and the unit is easily accessible for operation and maintenance.
- Install the unit in a housing or machine so that connecting units, flame arrester and control panels are easily accessible when removing or opening the housing access.
- Power cords and gas hoses must not be bent.
- Ambient temperature: -40 °C to +60 °C



NOTICE

Risk of overheating due to insufficient ventilation

The units generates heat. Possibility of heat damage and/or reduced service life of the unit.

- › Do not cover the unit.
- › Air must be able to flow in and out unobstructed.
- › Ventilation openings must be sufficiently large.
- › Installed units may require an independent ventilation system in unfavourable cases.

8 Vibrations

The unit generates vibrations.



CAUTION

The use of rigid connections may damage the units or the system in which the units have been installed.

- › Do not use rigid connection lines between the units and the system.

9 Installation position and fastening

Depending on the application, the unit can be installed in the stated permissible installation positions/areas in the fuel dispenser. In order to prevent the unit from completely filling up with condensation, the permitted installation area must be complied with.

- NOTICE**
Incorrect installation positions reduce the service life of the unit considerably.
- The manufacturer's warranty will no longer apply.
- Comply with the permitted installation position as shown.

Installation of the unit

For fastening the unit in the fuel dispenser there are two motor mounts with bores on the motor. The unit is fixed in the fuel dispenser using 4 screws. The permitted installation area must be complied with.

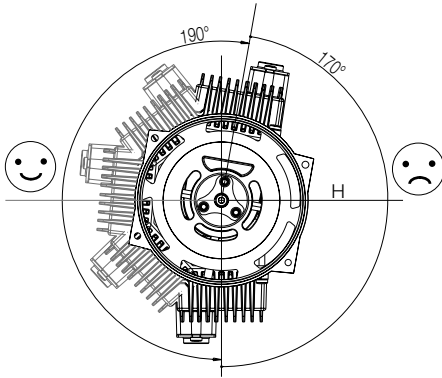

Figure 3: Installation position of the unit

H Horizontal

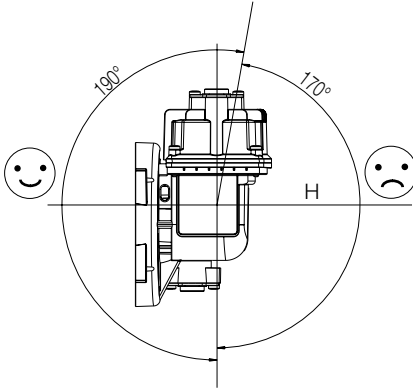

Figure 4: Installation position of the unit

H Horizontal

10 Installation

10.1 Electrical installation



DANGER

Connection to the power supply may only be performed by a qualified electrician.

- › Observe the regulations of the local power supply companies.
- › Before commissioning, verify that the power supply voltage complies with the voltage specifications of the type plate.
- › For information on the unit-specific mains fuse (short-circuit current) refer to the technical data (see "4 Technical data")
- › Only connect the unit to a power supply source with a correctly installed protective earth conductor.
- › Connect the unit in accordance with the relevant circuit diagram.
- › The unit should be electrostatically earthed.

Circuit diagrams

Type designation with the ending K

Electrical connection for units with 3-phase AC motor and 24 VDC start/stop relay. On motors without start/stop relay the relay cable is omitted.

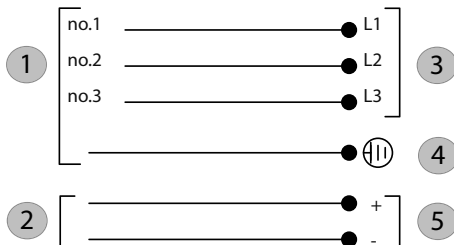

- 1 Motor cable (no. 1 to no. 3 and protective earth conductor)
- 2 Relay cable
- 3 3-phase mains
- 4 Protective earth conductor
- 5 Start/stop relay 24 VDC

Electrical connection for units with 3-phase AC motor and integrated 230 V single-phase start/stop relay. On motors without start/stop relay the relay cable is omitted (no. 4 and no. 5).

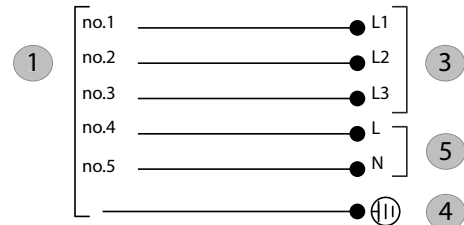

- 1 Motor cable (no. 1 to no. 5 and protective earth conductor)
- 3 3-phase mains
- 4 Protective earth conductor
- 5 Start/stop relay 230 V single-phase

Electrical connection for units with single-phase AC motor and 24 V start/stop relay. On motors without start/stop relay the relay cable is omitted.

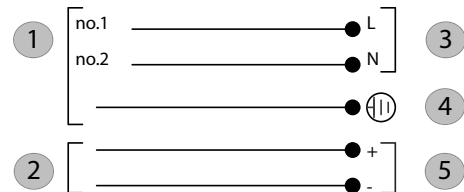

- 1 Motor cable (no. 1, no. 2 and protective conductor)
- 2 Relay cable
- 3 Single-phase mains
- 4 Protective earth conductor
- 5 Start / stop relay 24 VDC

Type designation with the ending G

Electrical connection for units with 3-phase AC motor and integrated 230 V single-phase start/stop relay. On motors without start/stop relay the relay cable is omitted (no. 4 and no. 5).



- 1 Motor cable (no. 1 to no. 5 and protective earth conductor)
- 3 3-phase mains
- 4 Protective earth conductor
- 5 Start/stop relay 230 V single-phase

Electrical connection for units with single-phase AC motor and integrated 230 V start/stop relay. On motors without start/stop relay the relay cable (no. 3) is omitted.

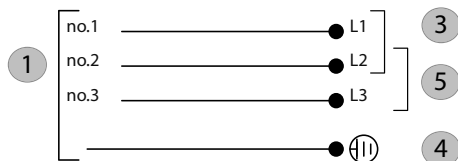

- 1 Motor cable (no. 1 to no. 3 and protective earth conductor)
- 3 Single-phase mains
- 4 Protective earth conductor
- 5 Start/stop relay 230 V single-phase



NOTICE
Overload and short circuit

Inadequate protection for the power supply circuit can lead to an overload and short circuit

- › The power supply circuits must be appropriately mains protected (short-circuit current) at all poles of the motors.

10.2 Motor protection

The motors are equipped with a temperature switch. The temperature switch switches the unit off and prevents overheating of the motor winding when the ambient temperature is too high.



NOTICE
Automatic start-up of the unit after cooling down

10.3 Direction of rotation

The units are equipped with fans that are independent of the direction of rotation. It is not necessary to specify the direction of rotation.

10.4 Flame arrestor and line connections



WARNING
Explosion hazard from spark formation

Flammable substances may ignite if the flame arrestors required by the manufacturer are not used.

- › Installation of the flame arrestors is a requirement for operation of the unit.

When connecting the gas recovery hoses to the unit, the requirements relating to proper use must be followed (refer to "2.1 Intended use").

The flame arrestors are equipped as standard with a G 1/4" female thread. Here the gas recovery hoses are connected with corresponding tube fittings. The suction-side connection (coming from the dispensing valve) of the gas recovery pump is marked with an arrow.

For some special applications the flame arrester is equipped with an NPT 1/4" female thread.



11 Operation



CAUTION

Burns from hot surfaces

The surfaces of the unit are hot during operation

- Allow surfaces to cool down before performing operating or maintenance work.

The unit is intended for installation in machines. To ensure perfect operation of the control part of the unit the following conditions must be satisfied:

- Ambient temperature: -40 °C to +60 °C
- The operating pressure of the outlet line must not be more than 150 mbar (150 hPa) above the ambient pressure.

12 Maintenance



Prior to working on the device or in case of danger, disconnect it from the mains (e. g. pull the mains plug).



CAUTION

Burns from hot surfaces

The surfaces of the unit are hot during operation

- Allow surfaces to cool down before performing operating or maintenance work.
- Only use accessories and special accessories that are specified or approved by Dürr Technik.
- Only use original working and spare parts.



Dürr Technik accepts no liability for damage resulting from the use of non-approved accessories, special accessories or any working parts or spare parts other than original parts.

12.1 Maintenance schedule

Maintenance interval	Maintenance work
Annually	<ul style="list-style-type: none"> - Surface, clean vents (refer to "12.2 Cleaning") - Check the flame arrester for dirt and wear (see "12.3 Flame arrester") - Check the rubber element of the coupling for wear (see "12.4 Checking the coupling")

12.2 Cleaning

The unit must be cleaned annually to guarantee perfect operation.

- › Clean the surface with a lint-free cloth.
- › Keep the ventilation openings of the crankcase chamber and cylinder head free from dust and impurities.

12.3 Flame arrestor

Within the scope of the type approval, the owner is obliged to perform a visual inspection of the flame arrestors annually. The flame arrestor must be checked for dirt and corrosion. Where necessary the flame arrestor should be cleaned or replaced.

The flame arrestors can be completely removed from the pump to allow them to be checked.

- › Loosen the fixing screws M5 x 12 on the flame arrestors.
- › Pull out the flame arrestors by the flange from the pump and check for dirt and wear.
- › Depending on the result of the check, either clean or replace the flame arrestors.
- › Reinstall the flame arrestors. Make sure that the O-ring is not damaged. Lightly greasing the O-ring eases assembly.
- › Screw the flame arrestors back onto the pump housing with the screws (tightening torque 5 - 6 Nm). Secure the thread with anaerobic adhesive (medium strength).

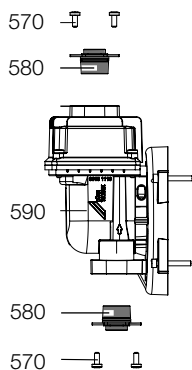

570 Fixing screws M5 x 12

580 Flame arrestor

590 Pump

12.4 Checking the coupling

The rubber element (600) of the coupling must be checked annually for damage and wear.

- › If wear is evident then the rubber element should be replaced.

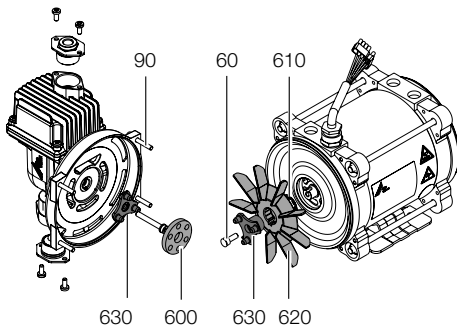

WARNING

Explosion hazard from spark formation

The pump must be operated with the rubber element

- › Check for correct seating of the rubber element.

12.5 Replacing the motor/pump

- › Remove the lines from the pump.
- › Disconnect the pump-motor screw connections (90).
- › Pull off the pump from the motor.
- › If necessary disassemble the fan assembly (see also Spare parts and accessories) from the motor. To do this, undo the screw (60) and pull off the fan assembly from the motor shaft.
- › Slide the new fan assembly onto the motor shaft and tighten the screw (60) to 12 Nm. Secure the thread with anaerobic adhesive.
- › Push the rubber element (600) onto the coupling element on the motor side. When doing so ensure that the 3 drive dogs of the motor end coupling element (630) are displaced by one borehole to the 3 drive dogs (630) of the pump end coupling element and engage the rubber element.
- › Slide the pump onto the motor flange (observe the position of the coupling element).
- › Tighten the fixing screws (90) with a torque of 5 - 6 Nm.
- › Re-connect the lines to the pump.

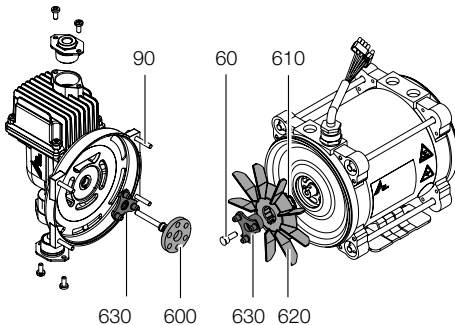

WARNING Explosion hazard from spark formation

The pump must be operated with the rubber element

- › Check for correct seating of the rubber element.

13 Taking the unit out of use

If the unit is not used for a lengthy period of time then we recommended shutting it down.

- › Unplug at the mains.
- › Disconnect the unit from the pipe system.
- › Remove the unit.
- › Completely clean the unit.
- › Store the unit in accordance with the storage conditions (refer to "2.8 Transportation and storage") and in the original packaging if possible.



14 Tips for operators and service technicians



Any repairs above and beyond routine maintenance must only be carried out by suitably qualified personnel or by one of our service technicians.



De-energise the unit prior to working on it or in the event of potential danger (e. g. pull the mains plug) and prevent it from being switched back on again.

Problem	Probable cause	Solution	
Unit does not start	No power supply voltage	› Check the mains fuse, the unit fuse and the mains connections.	
	Power supply voltage voltage too low	› Check the power supply voltage.	
	Open/closed-loop control defective	› Check the open/closed-loop control.	
	Mechanical sluggishness	› Factory repair	
	Motor defective	› Replace the unit.	
	The temperature switch in the motor switched off due to high ambient temperatures	› Allow the unit to cool down. Ensure better cooling. › Caution, unit restarts automatically!	
Poor delivery rate	1.Measuring system not OK 2.Open/closed-loop control not OK 3.Flow losses in the pipes too high	1.Check the measurement system and correct or replace 2.Check the open/closed-loop control and correct or exchange if necessary 3.Increase the size of the line cross-sections, reduce the line length and number of deflections, and check the lines for mechanical damage such as kinking. Clean the lines.	
	Flame arrestor dirty	› Clean and replace if necessary.	
	Control valve dirty or defective	› Clean the control valve and replace if necessary	
	Piston or shaft seal worn	› Factory repair	
	Pump valve faulty	› Factory repair	
	Mechanical sluggishness	› Factory repair	
	Motor speed too low	› Check the mains connection	
	Delivery rate too high	Fluid in the gas/bellows counter Gauge defective	› Clean or replace the gauge.

Problem	Probable cause	Solution
Unit too noisy	Pump or motor bearing defective	› Factory repair.
	Vibrations are transferred to the surroundings.	› Check the installation and if necessary stiffen the vibrating component, route it differently, provide support etc. Use flexible metal gas lines.
	Rubber element of coupling is defective	› Check the assembly of the rubber element, if necessary correct or replace.



Service

Dürr Technik GmbH & Co. KG
74301 Bietigheim-Bissingen
Telephone 0 71 42 / 90 22 - 20
Fax 0 71 42 / 90 22 - 99
e-mail: service@duerr-technik.de

Replacement order

Telephone 0 71 42 / 9022 - 0
Fax 0 71 42 / 9022 - 99
e-mail: office@duerr-technik.de

The following information is required when ordering spare parts:

- Type designation and item number
- Order number as appears on the spare parts list
- Quantity required
- Exact shipping address
- Shipping information

Repairs/return delivery

Ensure that the unit is **depressurized** before transport! Use the original packaging when returning units, if possible. Always pack the units in a plastic bag. Use recyclable packing material.

Return delivery address:

Dürr Technik GmbH & Co. KG
Pleidelsheimer Straße 30
74321 Bietigheim-Bissingen
-Germany-

International addresses for Dürr Technik

www.duerr-technik.com

Dürr Technik GmbH & Co. KG
Pleidelsheimer Strasse 30
74321 Bietigheim-Bissingen
Germany
Fon: +49 7142-90 22 -0
www.duerr-technik.com
office@duerr-technik.de

